

**Cambodian Students' Competency and Teaching
Material Development on Chemistry at
Secondary Level**

2016

SET SENG

**Cambodian Students' Competency and Teaching
Material Development on Chemistry at
Secondary Level**

By

SET SENG

Ph.D. Dissertation

Presented to the Joint Graduate School (Ph.D. Program)

in Science of School Education

Hyogo University of Teacher Education

January, 2016

DEDICATION

I would like to dedicate this dissertation to my parents Mr. KEO Set and Mrs. MEAV Im, to my grandfather in-law Mr. YOU Salat, to my mother in-law Mrs. YOU Sophal, to my beloved wife Mrs. UNG Sinon, to my dear children Ms. SENG Sreya, Ms. SENG Maneth and Ms SENG Pouv Panhaneath. Their precious love, encouragement and patience are uncountable to me and make me remember deeply in all my heart and soul. I wish they would be happy and satisfy with my achievement.

ACKNOWLEDGEMENTS

I would like to express sincere thanks to a number of people who have supported and encouraged me to complete this thesis possibly. First of all, I would like to offer my great gratitude to the Japan Society for the Promotion of Science (JSPS) and the Japanese Government that presented me the scholarship for this Ph.D. program and always have good cooperation, negotiation and support.

I would like to convey my deepest thanks to my supervisor Prof. Dr. Masakazu KITA for his precious guidance and valuable assistance throughout my research study program. His discussions and advices are very effective in helping me to improve and complete this dissertation fruitfully and successfully. I also would like to extend my thanks to other involved professors in Science Education Department, Graduate School of Education of Okayama University, for their helpful lessons, comments and encouragements.

Afterward, I would like to express my great gratitude to Mr. David Ford, of The Royal University of Phnom Penh in Cambodia, for helpful correction of my English and useful discussion in order to improve my Journal paper and this doctor dissertation.

I would also want to extend my thanks and appreciation to both my Japanese and Cambodian colleagues, to the principals, staffs and students of Amaki high school in Okayama city of Japan and Anuwat high school and National Institute of Education in Phnom Penh of Cambodia for their active cooperation, facilitations, and participations that allowed me to conduct and evaluate my study smoothly and successfully.

ABSTRACT

The main purpose of the research is to study students' competency on chemistry at lower secondary school in Cambodia and to develop teaching and learning apparatus from simple and available materials to support students' learning in Chemistry at secondary school. In order to achieve the research purposes, three research questions are posed:

1. To what extent do lower secondary school students in Cambodia understand the chemistry concept?
2. What teaching apparatus can be developed to support students' learning in chemistry at secondary school?
3. What are secondary school student's perceptions on the teaching and learning apparatus which were developed?

The research on Cambodian students' competency in Chemistry at lower secondary school can be shown through quantitative data analysis from 1304 Cambodian students in grade 8 (2nd year of lower secondary school) from 34 public schools across 17 provinces out of 25 throughout the country using the test paper designed by the Trends in International Mathematics and Science Study (TIMSS), 2011 standard. The study discussed the comparison by genders, areas, as well as within the regional countries and Japan whom participated in TIMSS-2011 standard. The results showed that Cambodian student's achievement was comparable to those of Thailand, Malaysia and Indonesia, however, they were all still below the ASEAN and international averages and far below Japan. The results also showed that there was not a significant difference in performance between male students (N=614, M=6.34, SD=3.044) and female students (N=690, M=6.44, SD=2.873); $p=0.537>0.05$. On the other hand, the students from the districts (N=655, M=6.56,

SD=2.971) seemed perform the test slightly better than those from the towns (N=649, M=6.28, SD=2.928); $p=0.043 < 0.05$, though their mean scores were just slightly different. The study was also discussed the implication of the results in the current Cambodian education context. The discussion came up with suggestions that Cambodia should pay increased attention to the reform of chemistry learning content and ways of teaching together with developing available teaching materials in order to encourage and provide students with enough opportunities to explore scientific practical work.

In terms of the development teaching and learning apparatus for secondary chemistry classroom, a number of simple apparatus had been assemble from available materials in daily life accompany with a number of teaching and learning activities in which all of those are relevant to the secondary chemistry curriculum. The materials for marbling ink, capillary method and dropping method were designed to investigate the effect of detergent on water surface tension. Fabric dyeing method and a hand-made photometer were developed to determine the concentration of detergent in the aqueous solution. In terms of conductivity concept, hand-made conductivity devices were assembled only from cheap materials and yet they could be applied to measure the conductivity of fruit or vegetable solution and that of thin-film semiconductor such as polypyrrole. Lastly, a dropping method was developed from dropping plastic gun balls along a column of sample solution to estimate the viscosity extent of sodium carboxyl methyl cellulose solution.

The students' perceptions on the teaching and learning materials and activities developed in the study can be shown through their application in the secondary schools in both Japan and in Cambodia as pilot lessons to examine their possibility in the real classrooms with the students. The results from the pre/post tests and questionnaires showed

that the developed materials could significantly hook the students' interests and help the students to construct their scientific knowledge and skills toward positive attitude in science. The students even showed much interest and enjoy the lesson activities, when they worked with the learning apparatus which were assembled from simple and inexpensive materials in their daily life. They could use the developed apparatus in their scientific investigation to achieve the lessons' objectives.

In summary, the study revealed the current level of students' competency in chemistry at lower secondary level compared to the countries in region, as well as the international standards. This finding provides a very important baseline, in which it can be used basically to develop perspectives to improve the quality of science education in the Cambodian school level to meet the regional and international standards. The research also provided a number of new developments of teaching and learning apparatus from available materials in daily life. The students showed high satisfaction to develop teaching and learning apparatus and the designed lesson activities which they could enhance their learning chemistry by experiments actively and improve their scientific knowledge and skills in the classrooms.

Keywords: students' competency, content domain, cognitive domain, development of teaching materials, detergent, surface tension, conductivity of aqueous solution, conductive polymer, viscosity of carboxyl methyl cellulose, intermolecular forces.

TABLE OF CONTENTS

DEDICATION	i
ACKNOWLEDGEMENTS	ii
ABSTRACT	iii
TABLE OF CONTENTS	vi
LIST OF TABLES	x
LIST OF FIGURES	xii
Chapter I: OVERVIEW OF THE STUDY	1
I. INTRODUCTION	2
II. RATIONAL.....	10
III. RESEARCH QUESTIONS.....	10
IV. LIMITATIONS.....	11
V. RESEARCH METHODOLOGY	12
REFERENCES.....	15
Chapter II: CAMBODIAN STUDENTS' COMPETENCY IN CHEMISTRY	
AT LOWER SECONDARY SCHOOL.....	17
I. INTRODUCTION	18
II. RESEARCH QUESTIONS	19
III. RESEARCH BACKGROUND.....	19
IV. RESEARCH METHODOLOGY	23
V. RESULTS AND DISCUSSION	27
VI. IMPLICATIONS FOR CAMBODIAN CONTEXT	35

VII. CONCLUSION AND SUGGESTION.....	40
REFERENCES.....	42
Chapter III: DEVELOPMENT OF TEACHING MATERIALS	
FOR LESSONS ON DETERGENT	46
I. DETERGENT	47
II. DETERGENT ANALYSIS BY WATER SURFACE TENTION.....	50
III. DETERGENT ANALYSIS BY FABRIC DYEING	63
IV. APPLICATION IN CLASSROOM.....	76
V. CONCLUSION	80
REFERENCES.....	81
Chapter IV: DEVELOPMENT OF HAND-MADE CONDUCTIVITY	
METER AND ITS APPLICATION TO FRUIT AND	
VIGETABLE SOLUTION.....	83
I. INTRODUCTION	84
II. ELECTRICAL CONDUCTIVITY	85
III. DEVELOPMENT OF HANDMADE CONDUCTIVITY APPARATUS	87
IV. APPLICATION OF HAND-MADE APPARATUS IN MEASUREMENT.....	93
V. APPLICATION TO CLASSROOM.....	99
VI. CONCLUSION.....	105
REFERENCES.....	107

Chapter V: DEVELOPMENT OF HAND-MADE CONDUCTIVITY

DEVICE FOR THIN-FILM SEMICONDUCTOR AND ITS APPLICATION TO STUDY THE EFFECT OF SURFACTANTS ON CONDUCTIVE PROPERTY OF POLYPYRROLE	108
I. INTRODUCTION	109
II. CONDUCTIVITY OF MATERIALS	111
III. DEVELOPMENT OF A HAND-MADE DEVICE.....	113
IV. APPLICATION TO POLYPYRROLE CONDUCTIVE PROPERTY	115
V. RESULTS AND DISCUSSION	121
VI. APPLICATION TO CLASSROOM.....	125
VII. CONCLUSION	130
REFERENCES.....	131

Chapter VI: DEVELOPMENT OF TEACHING MATERIALS TO EXAMINE

VISCOSITY OF CARBOXYL METHYL CELLULOSE.....	133
I. INTRODUCTION	134
II. VISCOSITY	135
III. CARBOXYL METHYL CELLULOSE	136
IV. VISCOSITY DETERMINATION AND DEVELOPMENT OF APPARATUS	137
V. RESULTS AND DISCUSSION	140
VI. APPLICATION TO CLASSROOM.....	144
VII. CONCLUSION	151
REFERENCES.....	152

Chapter VII: CONCLUSION	155
I. CAMBODIAN STUDNT’S COMPETENCY IN CHEMISTRY	156
II. DEVELOPMENT OF TEACHING MATERIALS	157
III. STUDENS’ PERCEPTION ON THE DEVELOPED MATERIALS	160
APPENDIX FOR CHAPTER II.....	162
APPENDIX FOR CHAPTER III	168
APPENDIX OF CHAPTER IV	188
APPENDIX OF CHAPTER V	201
APPENDIX OF CHAPTER VI.....	212
APPENDIX OF JOURNAL PUBLICATION	221

LIST OF TABLES

Table 2-1: Question items for chemistry collected from TIMSS 2011	24
Table 2-2: Descriptive statistics of Cambodian students.	28
Table 2-3: Number of students performed correct answers in summary	30
Table 2-4: Number of students performed correct answers in the properties of matter.	31
Table 2-5: Number of students performed correct answers in the classification and composition of matter.	31
Table 2-6: Number of students performed correct answers in the chemical change.....	32
Table 2-7: Number of students performed well in knowing scientific knowledge	33
Table 2-8: Number of students performed well in reasoning scientific knowledge.....	34
Table 2-9: Number of students performed well in applying scientific knowledge	35
Table 3-1: Some types of detergent in daily use.....	49
Table 3-2: Variation of the correction factor ϕ with $\frac{r}{\sqrt[3]{V}}$	54
Table 3-3: Types of fabrics and their polymer structures used in the study.....	65
Table 3-4: Types of anionic and cationic dyes used in the research	66
Table 3-5: Approximate wavelength of color and its complementary color	69
Table 3-6: The combination of fabrics and dyes used in the research.....	69

Table 4-1: Results of electrical conductivity of electrolyte solutions	93
Table 4-2: Conductivities by handmade apparatus and by commercial Shimadzu portable Kohlrausch bridge BF-62A.....	94
Table 4-3: Verification of the cell constant value with NaCl(aq) standards	96
Table 4-4: Conductivities by handmade apparatus and by commercial apparatus Shimadzu portable Kohlrausch bridge BF-62A	96
Table 4-5: Results of electrical conductivities of vegetables and fruits	97
Table 4-6: Electrical conductivities of vegetables and fruits solution by handmade apparatus compared with commercial apparatus.....	97
Table 4-7: The results of the titration	98
Table 5-1: Ratios of anionic and neutral surfactants in each 0.05M pyrrole solution	119
Table 5-2: Standardized data table comparing the handmade and conventional four-point probe technique	122
Table 5-3: Conductivity of Ppy by different dopants (surfactants).....	123

LIST OF FIGURES

Fig. 1-1: Students' experiences in scientific activities	4
Fig. 1-2: Science teaching ways of Cambodian teachers	5
Fig. 1-3: Teachers' concern in science practical works in Cambodian	6
Fig. 1-4: Secondary school situation in Cambodia.....	8
Fig. 1-5: Process of developing teaching and learning materials	13
Fig. 2-1: Score distribution of Cambodian students' achievement	28
Fig. 2-2: Students' performed the correct answers by question item and by country	30
Fig. 2-3: Summary of students' achievement in the content domain	32
Fig. 2-4: Summary of students' achievement in the cognitive domain	33
Fig. 3-1: Surfactants.	48
Fig. 3-2: Phenomenon of surface tension of water.....	51
Fig. 3-3: Water strider and small objects are help by the water by surface tension	51
Fig. 3-4: Meniscus curve and angle given by capillarity.....	53
Fig. 3-5: The Opposition between water surface tension and gravity on a water drop	53
Fig. 3-6: Experimental setup for capillarity	55
Fig. 3-7: The decrease in height of raised solution in the capillary with different detergent concentrations	56
Fig. 3-8: Experimental setup for drop-weight.....	58

Fig. 3-9: The decrease in weight of a sample drop against detergent concentrations	59
Fig. 3-10: Comparison of the two methods: capillarity and drop-weight	59
Fig. 3-11: Comparison of the effect on the surface tension of water between commercial detergent and sodium dodecyl sulfate (SDS).....	60
Fig. 3-12: Marbling ink and ink-printed papers	62
Fig. 3-13: The decrease in area of marbling ink against detergent concentration	63
Fig. 3-14: (a) Assemble of the hand-made reflection photometer; (b) measuring color depth of dyed fabric.....	65
Fig. 3-15: The relationship of CdS sensor property with the light	68
Fig. 3-16: The increase of color intensity when Cashimelon acrylic fabric dyed in methyl violet solution in the increase of detergent concentration	70
Fig. 3-17: The association between cationic dye and anionic detergent, (a) JIS MB method and (b) fabric dyeing.....	71
Fig. 3-18: Calibration curves of CdS resistance against SDS concentration.....	72
Fig. 3-19: The decrease of color intensity when Cashimelon Acrylic fabric dyed in Brilliant Blue in the increase of detergent concentration.....	73
Fig. 3-20: Calibration curve of CdS resistance against SDS concentration (case of acrylic fabric in brilliant blue).....	73
Fig. 3-21: Calibration curve of CdS resistance against SDS concentration (case of polyester and cotton fabric in methyl violet)	74
Fig. 3-22: Curves of CdS resistance against SDS concentration	

in different length of times.....	75
Fig. 3-23: Chemical interaction when acrylic fabric dyed in anion dye.....	75
Fig. 3-24: Students' performance on Pre-test and post-test	77
Fig. 3-25: Students' evaluated their understanding of the lessons	77
Fig. 3-26: The extent of difficulty of the activities in the lessons	78
Fig. 3-25: Students' satisfaction	79
Fig. 3-26: Extent of students' enjoyment in the lesson activities.....	79
Fig. 4-1: Variable resistor	88
Fig. 4-2: Electrode cell	88
Fig. 4-3: The handmade conductivity meter.....	89
Fig. 4-4: Diagram of the handmade conductivity meter.....	90
Fig. 4-5: Electrical conductivity of NaCl(aq), CuCl ₂ (aq), and AlCl ₃ (aq)	94
Fig. 4-6: Alkali contents in vegetable and fruit versus the conductivities	99
Fig. 4-7: Students evaluated their understanding of the lessons.....	101
Fig. 4-8: Students' performance on pre/post tests	102
Fig. 4-9: Students claimed their knowledge and skills acquired from the lessons	103
Fig. 4-10: Feasibility of using the hand-made apparatus by the students.....	103
Fig. 4-11: Students' satisfaction of the introduced activities and the handmade apparatus	104
Fig. 5-1: Illustration of passing current through a thin film material	111
Fig. 5-2: (a) Two-point probe technique, (b) four-point probe technique	112

Fig. 5-3:	(a) Conventional 4 point probe technique setup, (b) diagram of handmade device setup	113
Fig. 5-4:	(a) Assembly of handmade device, (b) four-point probe chip installation and its operation	114
Fig. 5-5:	Polypyrrole formation and its non-conductive and conductive forms	116
Fig. 5-6:	Molecular structures of the examined surfactants	120
Fig. 5-7:	Oxidative Ppy associated with anions of surfactant, a conductive polymer	121
Fig. 5-8:	Standardized data graph between handmade and conventional four-point probe technique	122
Fig. 5-9:	Conductivity of Ppy doped by anionic and neutral surfactants	124
Fig. 5-10:	Students evaluated their understanding of the lessons.....	127
Fig. 5-11:	Students' achievement on pre/post tests	127
Fig. 5-12:	Knowledge and skills students learned from the lessons.....	128
Fig. 5-13:	Extent of applicability with using the hand-made apparatus	128
Fig. 5-14:	Extent of students' satisfaction on the lessons activities and teaching materials.....	129
Fig. 5-15:	The interesting concept/activity for students.	130
Fig. 6-1:	Polymer structure of Carboxymethylcellulose (CMC) as sodium salt.....	137
Fig. 6-2:	Installation for dropping ball method	139

Fig. 6-3: Effects of metal ions on viscosity of aqueous 0.50% w/v CMC solution at 25°C	140
Fig. 6-4. Tyndall Effect of the sample solutions irradiated with 532 nm laser pointer	141
Fig. 6-5: Assumption of interactions between CMC polymer molecules and metal ions.	142
Fig. 6-6: Effects of metal ions on dropping speed in 0.50% w/v CMC(aq) at room temperature about 25 °C	143
Fig. 6-7: Relationship of dropping speed with viscosity at 25°C	144
Fig. 6-8: Students' results on investigation of the sample solution viscosities by the dropping ball method	146
Fig. 6-9: Students evaluated their understanding of the lessons.....	148
Fig. 6-10: Students' performance on pre/post tests	148
Fig. 6-11: Students claimed their knowledge and skills they learned	149
Fig. 6-12: Students' feasibility to operate the developed teaching and learning materials	149
Fig. 6-13: Students' satisfaction on the introduced lessons and teaching and learning materials.....	150
Fig. 6.14: The interest contents for students	151

Chapter I

OVERVIEW OF THE STUDY

I. INTRODUCTION

1. Nature of Chemistry

Chemistry is the study of matter properties related to physical, chemical and energy changes. It explains how and why substances combine or separate to form other substances, and how substances interact with energy. Chemistry is the central science as it bridges other natural science such as physics, biology and geology. Specialists of several fields like medicine, pharmacy, agriculture, environment, etc. need to understand chemistry concepts to explain the chemical-related phenomena in their application. Other word, chemistry is part of everything in our lives. All materials around us are made up of chemical elements, even our bodies. People are involving with chemistry every day from growing and cooking food to cleaning, as well as to launching a space shuttle. Chemistry is one of the physical sciences help us to describe and explain the world.

However, chemistry has been revealed by many researchers as one of the most difficult subjects for students at the basic education because it includes a number of abstract and complex concepts that requires special intellectual talents and a too much effort to be understood (Gabel and Bunce, 1994; Griffiths, 1994; Bucat and Fensham, 1995; Garnett, and Hackling, 1995; Hans, Annette and Allan, 2007; Rahayu and Kita, 2010). Perhaps more than other sciences, understanding chemistry relies on making sense of the invisible and un-touchable phenomenon. Though besides of the nature of the subject, the difficulties may also be related to way of learning and learner itself. According to Johnstone (1984, 1991), the reasons of students' difficulties can have at least three origins:

- 1) The nature of the science itself makes it inaccessible.
- 2) The methods by which teachers traditionally taught raise the problems and made the concepts in abstract.
- 3) The methods by which students learn are in conflict with either or both of the above.

Johnstone (1982) also raised that teaching and learning chemistry can be seen at least at three levels: The first level is actual observation in which students can see and handle materials, and describe their physical properties in terms of density, flammability, color and so on. The second level is the representational one in which students try to express chemical substances by formulae and their changes by equations. This is part of the sophisticated language of the subject. The third level is atomic and molecular representation, a level at which students attempt to explain why chemical substances behave the way they do. These ideas have later become the famous Johnstone's triangle (Johnstone, 1991). Therefore, learners need to gradually build up their basic knowledge along these three main conceptual steps in order to be able to understand chemistry.

Because chemistry is one of the science subjects, it plays a very important role in sustainable global development that could enrich the world with safe and modern science and technology. Since it is a kind of abstract and complex scientific concept, only theoretical introduction is not an effective way of learning, but also real practical work in and out of the classroom. In order to fulfill this potential, teaching and learning chemistry at school level needs enough resources, namely human and material resources, with high quality of utilization to assure students' learning achievement. The developed countries are seen to be able to provide the school with such resources, yet developing countries are still facing many difficulties due to they still don't have enough resources such as teaching and learning materials and contents. Like Cambodia, she is one of the developing countries and is facing these problems. The following describes the detailed situation and the requirements for chemistry education in Cambodia which provides the rationale behind this research.

2. Overview of Chemistry Education in Cambodia

In Cambodia, science is introduced basically from grade 2 of primary school, while chemistry concept is started from grade 4 of that up to the end of upper secondary school

(MoEY, 2009, 2011, 2012). At the primary level, only elementary chemistry concept is taught as integrated science discipline to get students familiar with a brief introduction of matter and its change related in daily life such as three states of matter, melting and burning. Then, at the lower secondary level chemistry is introduced together with other science subjects such as physics, biology and earth science as separate section of the same book and not as integrated science. At this level, students begin to learn the introductory chemistry focusing on more detail concept of matter, chemical element, chemical formula and some basic chemical reactions. The formal chemistry concept is started to teach at upper secondary level, where the contents are introduced in separate books from other science subjects.

Chemistry is only taught for 1 to 2 periods per week throughout grades 7 to 9 of lower secondary level shared with other science subjects, and it is applied for 2 periods per week through grades 10 to 12 of upper secondary level (MoEYS, 2004)⁽¹⁰⁾. The textbook is the only curriculum document provided by the Ministry of Education Youth and Sport (MoEYS), while the other teaching materials are shortage. Therefore, the textbook is virtually the only teaching resource available for teachers.

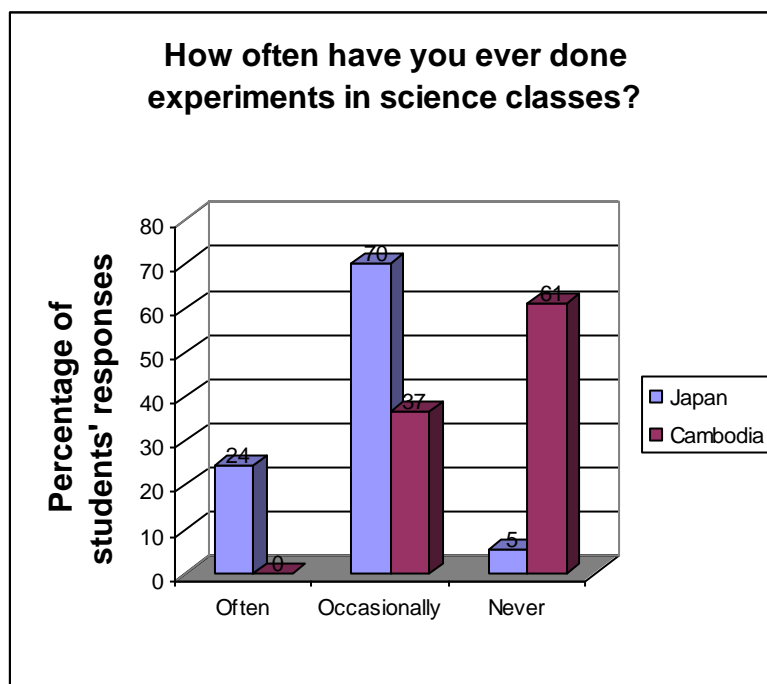

Fig. 1-1: Students' experiences in scientific activities (Seng's Master Thesis, 2007)

In your chemistry lessons, how often do you ask students to do...?.

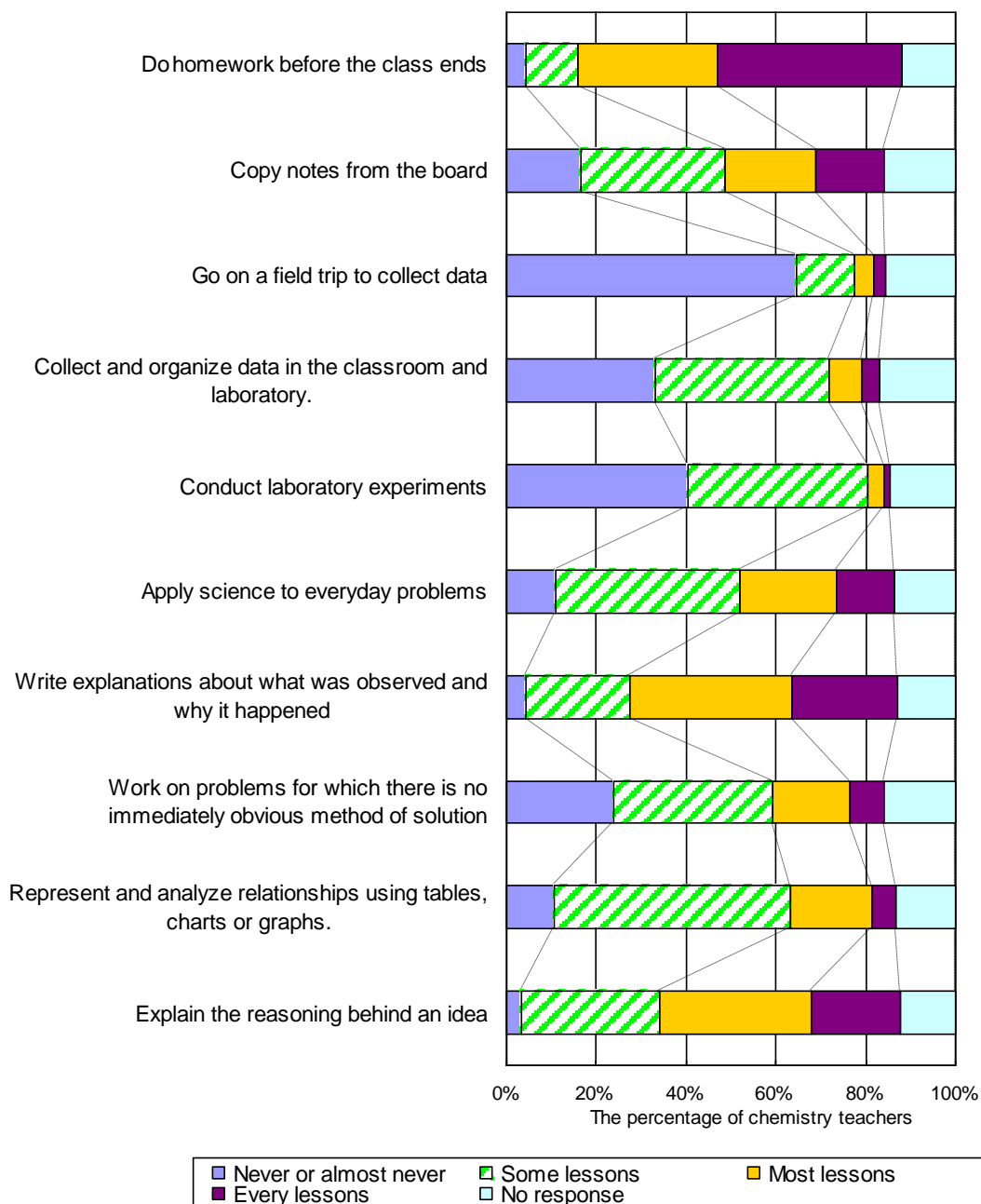

Fig. 1-2: Science teaching ways of Cambodian teachers (Maeda, 2003)

Like other science classrooms in Cambodia, students seldom experience active learning in chemistry as well as opportunity to observe real phenomenon through experiment in chemical laboratory. A survey in 2005 (**Fig. 1-1**) collected from 37 Japanese and 40 Cambodian high school students showed that most Cambodian students had never have

opportunity to observe science phenomenon through experimenting at all, and this is quite different from Japanese students (Seng's Master Thesis, 2007).

In general, the ways of teaching chemistry or science in Cambodia is that teachers ask students to read the textbooks, explain on chalkboard, and encourage students to remember what he/she has said. Students are rarely provided with an opportunity to observe real phenomena to link what they learn in the theory (Maeda, 2003) (see Fig. 1-2).

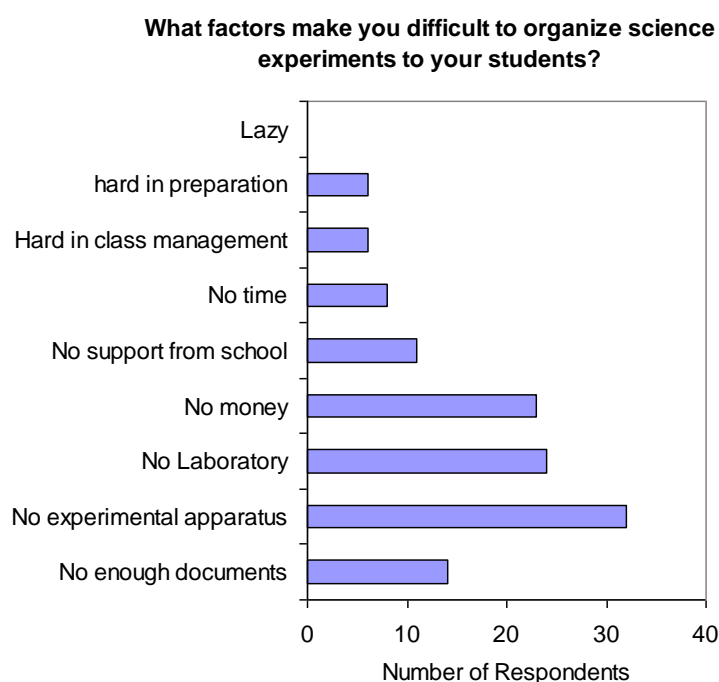

Fig. 1-3: Teachers' concerns in science practical works in Cambodian (Maeda, 2006)

Even though Cambodian teachers understood that the science activities, such as experiments can help students to interpret the phenomena of science concepts and to link from theory to practical work, in the context of Cambodia, science teachers found several factors that cause them could not introduce science practical works to students in the classrooms. As seen in Fig. 1-3, most of teachers concerned the lack of experimental apparatus and laboratory (Maeda, 2006). This is still valid for the current situation found by a survey conducted by National Institute of Education of Cambodia (NIE, 2014) in which

showed that most of the schools in Cambodia still continue facing with the lack of teaching and learning materials and science laboratory.

Although several attempts have been made by the Cambodian government through the Ministry of Education Youth and Sports to reform the education system in Cambodia, several researchers have shown that science education in Cambodia is still in much need of improvement. According to Maeda, Pen, Set, Kita & Sieng (2006), the quality of science education in Cambodia is facing three key issues: (1) shortage of appropriate educational content, (2) insufficient teaching and learning materials, and (3) lack of qualified, trained teachers. A baseline survey conducted by the Japanese, Cambodian Science Teacher Education Project, (STEPSAM2), also reported that science trainers from teacher training centers for primary and lower secondary school as well as their trainees, who become lower secondary teachers, demonstrated poor scientific knowledge and weak scientific thinking or few science process skills (STEPSAM2, 2009). Recent research by Walle, Uon, Cnudde and Keo (2010) and Chantha, (2013) has shown similar results.

<Educational content>

Cambodia still doesn't have appropriate educational content (science textbooks) to teach 'science' at secondary levels. Many of the practical activities which are introduced in the current curriculum and textbooks do not follow the nature of learning science. The practical works found in all science textbooks, including chemistry, has several common problems which are as follows:

- Materials and equipment described in the contents are not available in schools.
- The procedure requires pure laboratory operation or industrial processes, which are not available.
- The experimental procedure is too complicated and inadequately described for inexperienced Cambodian teachers and students.
- The content has little relationship to students' daily lives.
- The content does not interest students.

- The objective is not stated clearly.
- Most of the illustrated diagrams and Figures are inaccurate.
- Experiments do not follow the scientific method. That is, the content does not facilitate learners to predict and analyze the experimental results.

<Teaching and learning materials>

Like many other developing countries, Cambodia doesn't have enough science teaching and learning materials such as reference books, laboratory equipment and chemicals. Besides textbooks published by the MoEYS, Cambodia doesn't have any other science reference books, especially, those written in Khmer language. Most schools, especially in the remote areas, do not have a laboratory, science equipment, or a water supply as shown in NIE survey in 2012 (**Fig. 1-4**).

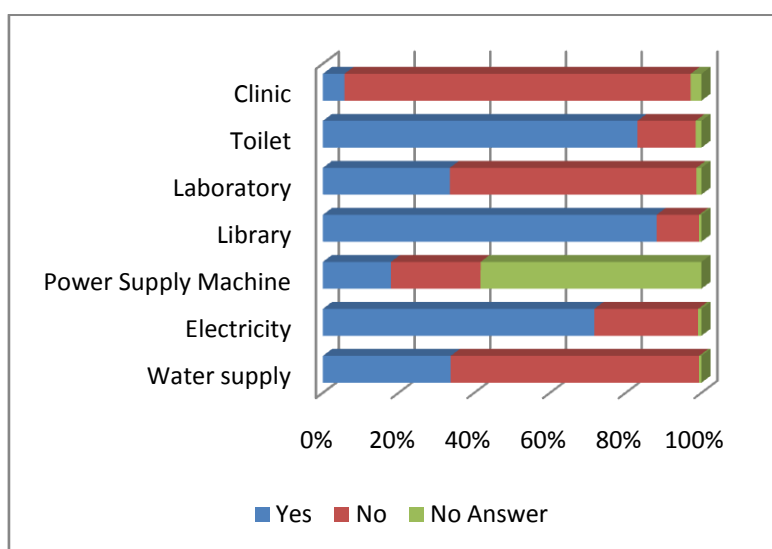

Fig. 1-4: Secondary school situation in Cambodia (NIE, 2012)

Although some schools have laboratory equipment and chemicals provided by France, Vietnam, Russia and other donors, there have been a number of problems related to the proper use of this equipment as follows:

- There are not enough skilled teachers to maintain or repair the equipment and chemicals in the science kits.

- The replacement of equipment and chemicals when broken or used up is not easy in Cambodia.
- The operation of equipment is not easy for inexperienced teachers and students.
- The operating manuals of the equipment and the labeling of chemicals are written in other languages than Khmer, so most teachers and students don't understand them.
- There are some dangerous chemicals provided without sufficient safety precautions.

<Quality of teachers>

The quality of teachers is another important factor that affects the quality of science education in Cambodia, the lack of competent teacher is a significant problem. It is believed that, even though experiments in textbooks were not well prepared, competent teachers could potentially revise them or develop appropriate alternative experiments. Moreover, competent teachers could produce teaching materials from those locally available even if they were not provided by the ministry or school. Competent teachers might also have the ability to utilize and maintain donated lab equipment and chemicals. Thus, the quality of teachers is seen to be of particular importance in less developed countries.

Unfortunately, there are few such competent teachers in Cambodia. The science and mathematics education survey conducted by MoEYS (1998) found that:

- Many teachers did not provide appropriate examples and demonstrations in such a way that students could link and integrate ideas
- There was a tendency for teachers to utilize only closed questions, in which a one-word answer was the usual outcome
- Teachers had little or no experience of practical science
- The majority of teachers were not able to recognize scientific terminology

Conclusively, chemistry same as other science subjects is faced with several problem factors due to the current context of Cambodia. These are surely affected the student learning achievement. Development of simple teaching and learning materials is thought to be useful to help Cambodian students in the current learning situation, so that they would have opportunity in scientific observation and link from theory to real practice.

II. RATIONAL

Currently, Cambodian Government through the ministry of Education, Youth and Sport (MoEYS) is conducting several reforms in the education system aiming to improve the quality of student learning in the classroom at the basic education, especially in science. One of the reforms is to revise the school curriculum for science and math. The current science curriculum and the textbooks are reviewing and the new ones will be developed afterward. The new curriculum and syllabus are planning to complete in the end of 2016, and following by the textbook development in 2017. It is believed that the new curriculum will provide students more opportunity to develop their scientific knowledge and skills with more practical works and research assignment inside and outside the classroom through inquiry based approach and link with daily life. Therefore, as Cambodia is a developing country which is still lacking the resources, the development of teaching and learning apparatus from available and inexpensive materials are helpful and useful for the implementation of the new revising curriculum.

III. RESEARCH QUESTIONS

As was shown in the background mentioned above, the research on “**Cambodian Students’ Competency and Teaching Material Development on Chemistry at Secondary Level**” is proposed. The main purpose of the research is to study students’ competency on

chemistry at lower secondary school in Cambodia and to develop teaching and learning apparatus from simple and available materials to support students' learning in Chemistry at secondary school. In order to achieve the search purpose, three research questions are posed:

1. To what extent do lower secondary school students in Cambodia understand the chemistry concept?
2. What teaching apparatus can be developed to support students' learning in chemistry at secondary school?
3. What are secondary school student's perceptions on the teaching and learning apparatus which were developed?

IV. LIMITATIONS

In the process of research, teaching and learning materials from cheap and available material in daily life are developed and designed for secondary school level. However, because of limited time, only selected lesson topics were chosen to develop the teaching and learning apparatus. All developed apparatus were introduced as trial to students in Japan and some in Cambodia in order to determine their feasibility in the real classroom. The trial lessons with Japanese students were conducted in English, which is not the main medium of communication in Japanese schools. Therefore, the results might have been influenced by the level of students' understanding of English. However, the lessons in Cambodia were conducted in Khmer languages, which is the mother tongue of the Cambodian students. The feasibility of using the developed teaching and learning materials in the classrooms was examined through the students' performance on pre/post tests and the students' perceptions on ending lesson questionnaires. In the case of pre and post tests, the same questions were designed in order to alleviate the data analysis for evaluation of students' improvement.

V. RESEARCH METHODOLOGY

1. Cambodian Students' Competency

Case of the research question on Cambodian students' competency in Chemistry, the data is collected quantitatively from Cambodian students at grade 8 (2nd year of lower secondary school) using the test paper designed by Trends in International Mathematics and Science Study (TIMSS), 2011 standard. The data is analyzed by SPSS program (PASW statistics 18, version 18.0.0, July 30, 2009) to run for data deviation in T-test comparing by genders, areas, as well as to regional countries and Japan whom also participated in TIMSS-2011 standard.

2. Development of Teaching and Learning Materials

The development of teaching and learning materials was carried out by following the six steps as shown in **Fig. 1-5**.

<Determining topics>

The first important starting point was to determine the topics for developing teaching and learning materials. As mentioned in the rational of the study, topics must be strongly linked to student's daily life and applicable in the secondary curriculum in Cambodia. Furthermore, these topics are believed to be feasible and physically possible in typical Cambodian classrooms.

<Developing teaching and learning materials>

After the topics had been selected, the teaching and learning materials namely experimental apparatus to conduct the practical work was developed and then tested by conducting several experimental trials in the laboratory. The development was trying to use most of the apparatus is available and inexpensive. The ways to set up and use the apparatus were designed to be simple and uncomplicated for students. The apparatus was standardized

with actual laboratory apparatus and so the experimental results obtained showed good consequence with theory.

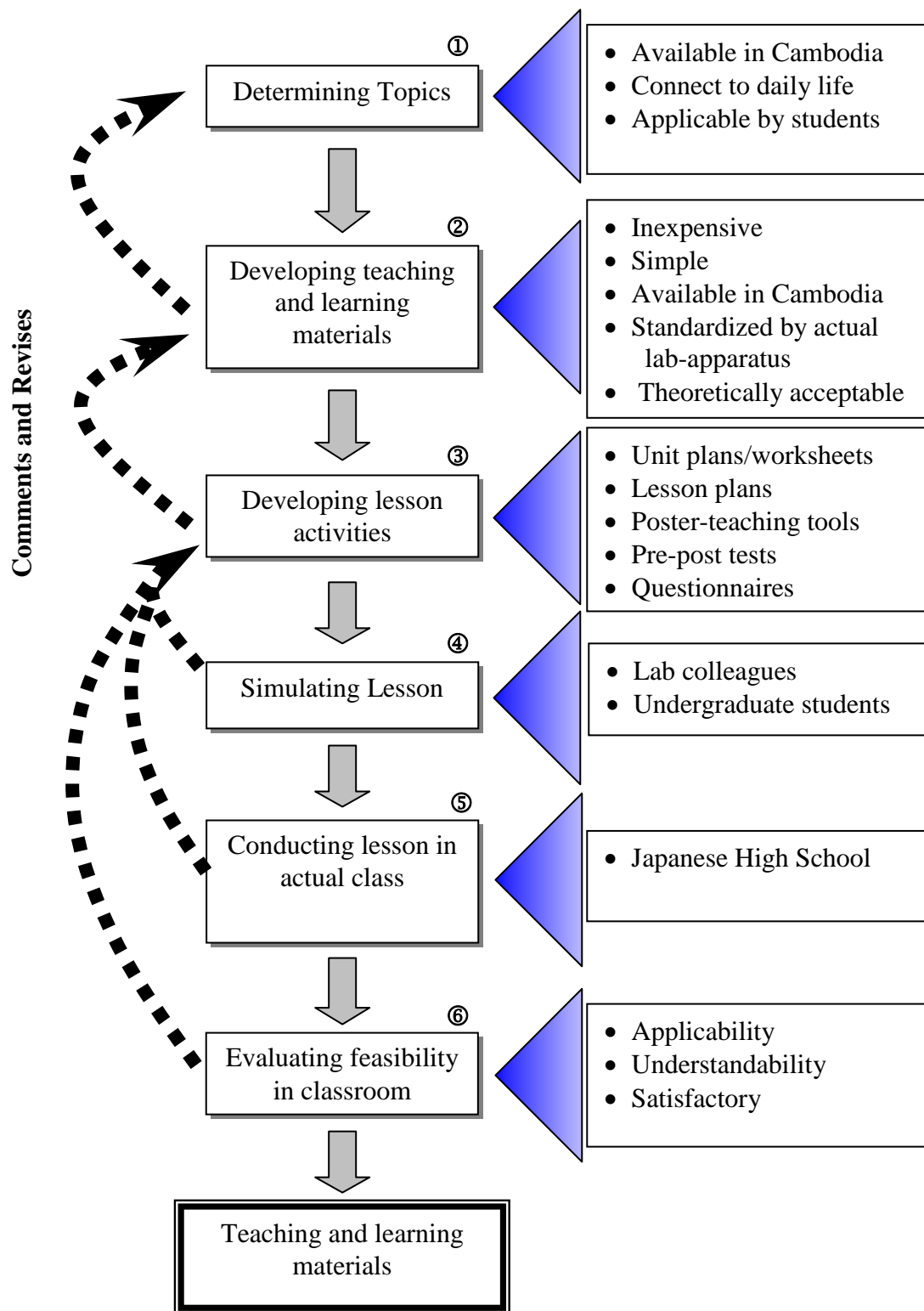

Fig. 1-5: Process of developing teaching and learning materials

<Developing lesson activities>

The lesson activities were prepared after the experiments and apparatus had been developed and tested to see that they were usable in actual classrooms. Several necessary documents such as lesson summary, student worksheets, lesson plans, posters, pre/post test etc. were produced for use in the classroom. Student worksheets and lesson plans were prepared using the inquiry based approach format, in which students formulate an experimental hypothesis, make observations, collect data, analyze results and make conclusions.

<Simulating lessons>

Before introducing the lessons to the actual classrooms, some simulation lessons were conducted. The participants were under-graduate and graduate students from the inorganic chemistry laboratory, as well as supervisor. The aim of this step was to collect ideas to improve the teaching and learning materials and the teaching approaches.

<Conducting lesson in actual classroom>

The learning materials were used by students in the classroom through a complete step of lesson instruction. Following the inquiry based approach, the students formulated their hypothesis, use the developed apparatus to investigate the hypothesis and present their results.

<Evaluating feasibility>

The feasibility of the developed teaching and learning materials in the classroom was measured based on the students' performance on pre/post tests and the students' perception on questionnaires. Before the lessons, the students were asked to complete the pre-test which consisted of multiple choice questions that were related to the lesson contents to be taught. At the end of the activities, students were requested to answer the post-test, consisting of the same questions as the pre-test, and to fill up the questionnaires. The pre/post tests assessed the students' understanding and improvement, whereas the questionnaires examined the feasibility and suitability of the developed apparatus and activities.

REFERENCES

- Bucat, Bl, &Fensham, P. Selected papers in chemistry education research implications for the teaching of chemistry. Delhi: Shatabdi Computers, 1995.
- Chantha, C. Examination of science process skills of elementary teacher trainees in PTTCs in Cambodia. *Master Thesis*, Hiroshima University, Japan, 2013
- Gabel, D.L.k&Bunce, D.M. Research on problem solving. In D. Babel (Ed), *Handbook of research on science teaching and learning*. New York: Macmillan, pp. 301-326, 1994
- Garnett, P.J., Garnett, P.J., & Hackling, M. W. Students alternative conceptions in chemistry: A review of research and implications for teaching and learning. *Studies in science education*.25, pp, 69-95, 1995
- Griffiths, A.K. A critical analysis and synthesis of research on students' chemistry misconceptions.In H.-J. Schmidt (Ed.), *Problem solving and misconceptions in chemistry and physics*, Hong Kong: ICASE, pp.70-99, 1994
- Hans-J.S., Annette. M., & Allan.G.H. Factors that prevent learning in electrochemistry. *Journal of Research in Science Teaching*, 44 (2), pp. 258-283, 2007
- Johnstone, A. H. Macro-and micro chemistry. *School Science Review*. 64(227), 377-379, 1982
- Johnstone, A. H. New Stars for the Teacher to Steer by? *Journal of Chemical Education*, 61(10), pp. 847-849, 1984.
- Johnstone.A.H. Macro and microchemistry.*School Science Review*,64, pp. 377-379, 1982
- Johnstone.A.H. Thinking about thinking. *International Newsletter on Chemical Education*, 6, pp. 7-11, 1991
- Maeda, M. Cambodian Chemistry Teacher Survey. *STEPSAM*, Cambodia, 2006.
- Maeda, M. Chemistry Practical Work in Classroom. *STEPSAM*, Cambodia, 2003.
- Maeda, M., Pen, S., Set, S., Kita, M., &Sieng, S. The quality of science teachers in Cambodia: From Problem to a Solution. HCMC: IRD-IER-NIESAC, 2006
- MoEY, Lower Secondary Science Textbook (Grade 7, 8 & 9), *Ministry of Education, Youth and Sport*, Cambodia, 2009.

- MoEY, Primary Science Textbook (Grade 4, 5 & 6), *Ministry of Education, Youth and Sport*, Cambodia, 2012.
- MoEY, Upper Secondary Chemistry Textbook (Grade 10, 11 & 12), *Ministry of Education, Youth and Sport*, Cambodia, 2011
- MoEYS, Policy for curriculum development 2005-2009. *Ministry of Education, Youth and Sport*, Cambodia, 2004
- NIE, Teaching Effectiveness of Newly Upper Secondary School Teacher, *National Institute of Education*, 2014.
- NIE, Teaching Effectiveness of Newly Upper Secondary School Teacher, *National Institute of Education*, 2012.
- Rahayu, S & Kita, M. An analysis of Indonesian and Japanese students' understandings of macroscopic and submicroscopic levels of representing matter and its change. *International Journal of Science and Mathematics Education*, 8 (4), pp. 667-688, 2010
- Seng, S. Development and Effectiveness Study of Chemistry Teaching Materials for Upper Secondary Schools in Cambodia: Unit Planning on Detergent and Conductivity. *Master Thesis*, Okayama University, 2007.
- STEPSAM2. Baseline Survey Report. Cambodian Science Teacher Education Project. PADECO CO., LTD & HIROSHIMA University, 2009
- Wall, S. V., Uon, V, Cnudde, V., & Keo, M. Strengthening student centered approaches in science teaching in Cambodia. VVOB, Cambodia, 2010

Chapter II

CAMBODIAN STUDENTS' COMPETENCIES IN CHEMISTRY AT LOWER SECONDARY SCHOOL

I. INTRODUCTION

Cambodia will face increasing regional competition when ASEAN integration becomes a reality in 2015. Its competitive status will depend greatly on the capacity of its human resources. Numerous reports have described the lack of relevant knowledge and skills of graduates from the Cambodian school system (Neth & Wakabayashi, 1999; UNESCO, 2001; MoEYS, 1998). Yet there is little reliable quantitative data to support these claims. Especially, there is little subject specific, comparative data that might indicate Cambodia's regional competitive status.

Science education plays an important role in the development of critical citizens in a rapidly changing technological society (Ginns & Watters, 1995; Watters & Ginns, 2000). McGinn and Roth (1999) emphasize that by well-organized science education, citizens can have a greater understanding of natural and scientific phenomena, and can develop skills to solve challenges they may encounter in daily life.

Chemistry is widely considered to be a central discipline among the sciences as it closely studies matter, energy and their interactions in the phenomena of our everyday lives. Understanding chemistry can help to explain changes in matter as well as many phenomena in nature (Mann, 2011).

Unfortunately, Cambodia has never participated in an international assessment such as Trends in International Mathematics and Science Study (TIMSS) or Programme for International Student Assessment (PISA) before, whereas several of her regional neighbors have (TIMSS, 2013; PISA, 2013). Consequently, this investigation aims to describe Cambodian students' competency in chemistry at lower secondary level through the use of internationally recognized TIMSS test items in both concept and cognitive domains, and compares them with Japan and other regional countries such as Thailand, Malaysia and Indonesia.

II. RESEARCH QUESTIONS

Giving the above context, this research aims to explore Cambodian lower secondary school students' competencies in chemistry by using TIMSS-2011 standard items. Here, the competencies are referring to the ability of students to understand the chemistry concept domain and scientific cognitive domain. The research raises the following investigative questions:

1. To what extent do lower secondary school students in Cambodia understand the chemistry concept domain?
2. How well do Cambodian lower secondary school students perform on the three components of the cognitive domain; knowing, reasoning and applying scientific knowledge?
3. What differences in performance are there between Cambodian students and those of the ASEAN countries, Japan and the international averages?

III. RESEARCH BACKGROUND

1. The Cambodian Context

Cambodia is one of the least developed countries in the world. It experienced civil war for several decades during the 1970s to 1990s, the most serious being from 1975 to 1979 in which numerous educational resources, both human and material, were destroyed. Since then, the education system in Cambodia has been reformed several times under the support of various educational projects from foreign countries (UNESCO, 1991; Clayton, 1997; Chantha, 2013) yet the system remains in a weakened state with an undertrained and underpaid workforce, inadequate curriculum, poor teaching and learning resources and so on that demotivates students for learning.

In the current educational system in Cambodia, Chemistry is introduced in grade 7 of lower secondary school together with other science discipline such as Physics, Biology and Earth Science. They are presented as separate sections of the same book and not as integrated science. The textbook is the only curriculum document provided by the Ministry of Education Youth and Sport (MoEYS) and there is a shortage of other teaching materials, so it is virtually the only teaching resource available for teachers. At this level, chemistry is only taught for 1 to 2 periods per week throughout grades 7 to 9 shared with other science subjects (MoEYS, 2004).

Although several attempts have been made to reform the education system in Cambodia, several researchers have shown that science education in Cambodian is still in much need of improvement. A research conducted by Maeda showed surprisingly that the students of Royal University of Phnom Penh specialized in chemistry had low performance on science items for lower secondary standard by TIMSS (Maeda, 2003). According to Maeda, Pen, Set, Kita & Sieng (2006), the quality of chemistry education, as well as science education in Cambodia is facing three key issues: (1) shortage of appropriate educational content since most is too abstract, has little practical work, many theoretical concepts and few links to everyday application, (2) insufficient teaching and learning materials that encourages teachers to teach students mostly by rote lecturing following what is written in the textbook without providing students with real scientific observation and, (3) lack of qualified, trained teachers. The research shows that many teachers have had little or no experience in science practical work, as they have never been trained in the pre-service teacher-training program at teacher training centers. A baseline survey conducted by the Japanese, Cambodian Science Teacher Education Project, (STEPSAM2), also reported that science trainers from teacher training centers for primary and lower secondary school as well as their trainees, who become lower secondary teachers, demonstrated poor scientific knowledge and weak scientific

thinking or few science process skills (STEPSAM2, 2009). Recent research by Walle, Uon, Cnudde and Keo (2010) and Chantha, (2013) has shown similar results.

The Structure of the school system in Cambodia is the same as that in Japan, Thailand and Indonesia; 6 years of primary education, followed by 3 years of lower secondary education and 3 years of upper secondary education. Malaysia is slightly different since its primary school students start school at 7 years of age and study for 6 years, followed by 3 years of lower secondary education and 2 years of upper secondary education. However, before entering the university, Malaysian students need to study for another year called pre-university.

2. The Nature of Chemistry

Many researchers have found that chemistry is one of the most difficult subjects for students because it includes a number of abstract concepts that are difficult to understand (Gabel and Bunce, 1994; Griffiths, 1994; Bucat and Fensham, 1995; Garnett, and Hackling, 1995; Hans, Annette and Allan, 2007; Rahayu and Kita, 2010). According to Johnstone (2000), the difficulties may be related to human learning as well as the nature of the subject itself.

The subject of chemistry comprises different kinds of concepts compared to others. Johnstone (1982, 1991&2000) describes three levels of chemistry concepts for learners; the macro and tangible, the submicro atomic and molecular, and the representational use of symbols and mathematics. In the case of the macro level, it is possible to have direct concept formation, as in the case, for instance, of recognizing metals and non-metals, acids and bases, flammable substances, etc. In the case, however, of concepts like elements or compounds, molecules, atoms, or electrons, bonding types, these involve the submicro level and are very difficult concepts for students. Furthermore, to interpret and express the phenomenon of

chemical change, scientific symbols and mathematics are used. Therefore, learners need to gradually build up their basic knowledge of these three main component concepts in order to be able to understand chemistry.

3. TIMSS

TIMSS is the abbreviation of “Trends in International Mathematics and Science Study”. It is an internationally comparative assessment dedicated to improving teaching and learning in mathematics and science for students around the world. By carrying out evaluations every four years since 1995 at the fourth and eighth grades, TIMSS provides data about trends in mathematics and science achievement of students around the world over time. In 2011, there are nationally representative samples of students from 63 countries and 14 benchmarking entities (regional jurisdictions of countries, such as states) participated in TIMSS. Two dimensions have been developed by TIMSS science assessment teams:

- (1). A content dimension specifying the domains or subject matter to be assessed within science; and
- (2). A cognitive dimension specifying the domains or thinking processes expected of students as they engage with the science content.

The domain of knowing scientific knowledge is the knowledge of relevant science facts, information, tools, and procedures, while applying scientific knowledge refers to the use of knowledge in real situations and problem solving. Lastly, reasoning scientific knowledge is the skill of drawing conclusions with appropriate evidence based on inductive and deductive reasoning as well as the investigation of cause and effect (TIMSS, 2013).

The cognitive domain is an area of study that focuses on the processes and the qualitative results of the study as well as the ability to apply intelligence. Cognitive domain is well-known as one of Bloom's taxonomy learning domains commonly used to describe a

student's intellectual development. According to Bandura (1989), a major function of thought is to enable people to predict the occurrence of events and to create the means of exercising control over those that affect their daily life, and this requires cognitive processing. In order to do this, people must draw on their state of knowledge to generate hypotheses and apply a process to solve the problem. According to Hanus, Hamilton & Russell (2008), there are six categories in the cognitive domain, namely knowledge, comprehension, application, analysis, synthesis and evaluation. He refers to knowledge as a cognitive continuum that begins with students' recall and recognition of a concept, while comprehension is the ability to translate or to interpret the concept. He refers to application as the ability of students to apply the knowledge that they comprehend. Analysis and synthesis he explains as the ability of students to analyze situations involving their knowledge and to synthesize the knowledge into new organizations. Finally, students need evaluation skills to evaluate the knowledge area to judge the value of materials and methods for a given purpose.

IV. RESEARCH METHODOLOGY

1. Research Materials

The study used only question items developed by TIMSS in 2011 for eighth grade. Among the 217 assessment items for all science areas, the author selected all 18 items that related to chemistry. Among the items selected, 13 were multiple-choice questions where students could select an option that would best represent a particular concept, and 5 items were constructed response questions where students could write an appropriate explanation.

As seen in **Table 2-1**, the items covered 3 topic areas in the chemistry concept domain, namely the properties of matter, classification and composition of matter and chemical change. They were also classified into 3 categories of cognitive domain; knowing,

applying and reasoning scientific knowledge. Two among the 18 items were worth 2 marks, while the others were 1 mark questions; therefore the full score was 20.

Table 2-1. Question items for chemistry collected from TIMSS 2011

Question Items	Question ID	Topic Area(Concept Domain)	Cognitive Domain	Maximum Scores
1	S032156	Properties of matter	Reasoning	1
2	S032056	Chemical change	Applying	1
3	S052152	Classification and composition of matter	Applying	1
4	S052136	Classification and composition of matter	Reasoning	1
5	S052046	Chemical change	Knowing	1
6	S052254	Properties of matter	Reasoning	1
7	S042076	Classification and composition of matter	Knowing	1
8	S042306	Classification and composition of matter	Knowing	1
9	S042100	Chemical change	Knowing	2
10	S032502	Classification and composition of matter	Applying	1
11	S032679	Chemical change	Applying	1
12	S042073	Classification and composition of matter	Knowing	1
13	S042095	Properties of matter	Knowing	1
14	S042112	Chemical change	Knowing	1

15	S042063	Classification and composition of matter	Applying	1
16	S042305	Classification and composition of matter	Applying	2
17	S032579	Classification and composition of matter	Applying	1
18	S032570	Classification and composition of matter	Reasoning	1

The detailed question items are available in the APENDEX or accessible from TIMSS 2011 website: <http://timss.bc.edu/timss2011/>

The items were translated into Khmer language and checked several times by our colleagues, chemistry lecturers of National Institute of Education, to make sure that the translated items could be understood properly by students. Then, the translated question items were used with two classes of eighth grade students as a pilot. Students in the pilot study didn't raise any questions related to the translated items, so it was assumed that the translated questions were suitable for use with Cambodian students.

2. Sample and Data Collection

Following the TIMSS framework, eight grade Cambodian students were asked to participate in the research at the end of their school year from June to July, 2013. They were selected randomly from 1 to 2 classes from 34 public schools across 17 provinces/cities out of 25 throughout Cambodia, in which 1 school in town (city) and 1 school in district were collected for each province. There were 1304 students (690 were female) in total who participated in the research. The participating students were given 1 hour to write answers on

the TIMSS test papers in classrooms and supervised strictly and no cheating of any type was allowed.

The collected questionnaires were marked following the instruction of correction guide by TIMSS. For multiple-choice questions students were given one mark if they chose the correct answer and zero if they chose the wrong one. In the case of constructed response questions students were given one or two marks based on their use of correct key terms to express their answers.

Data from Japan, Thailand, Malaysia and Indonesia, were collected by the author from the TIMSS 2011 database, which had already been statistically adjusted and reported the students' achievement as average percentages. These data were used directly to compare with Cambodian students' achievement. Moreover, the ASEAN average is calculated from the average of ASEAN countries which participated in TIMSS 2011, namely Thailand, Malaysia, Indonesia and Singapore, and plus this Cambodia data. However, Singapore will not be raised to discuss in the comparison by country, because it is already found as a top performance in the TIMSS similar to Japan. Therefore, the discussion will compare solely between Cambodia, Thailand, Indonesia and Malaysia where the educational situation is considered to be similar as they are all the developing countries in the region.

3. Data Analysis

The students' scores obtained on the test were analyzed quantitatively using Microsoft EXCEL to calculate the average number of students who gave the correct answers and SPSS (PASW Statistics 18, version 18.0.0) to run for descriptive statistics and T-test. The data collected from Cambodia, was then compared with the secondary data of Japan, Thailand, Malaysia and Indonesia collected from TIMSS 2011 results and differences in achievement between countries in terms of concept and cognitive domains were identified.

V. RESULTS AND DISCUSSION

The discussion of the research finding is focused on two main areas as mentioned in the research questions. First, students' overall understanding of the chemistry concept domain is discussed, followed by general patterns for each topic area introduced in the assessment test, namely, properties of matter, classification and composition of matter, and chemical change. Second, the discussion focuses on students' performances in the cognitive domain. Here, three student competencies are considered; the abilities of knowing, applying and reasoning scientific knowledge. For each discussion, a comparison is made between the Cambodian students' achievement and that of Japan, Thailand, Malaysia and Indonesia as well as the ASEAN and international averages.

1. Students' Understanding of the Chemistry Content Domain

<In General)

Fig. 2-1 and **Table 2-2** show Cambodian students' overall understanding of the chemistry concept domain in the test. It can be seen that the majority of Cambodian students performed lower than average scores. They got only 6.39 or 31.95% on average out of the total 20 score on the 18 items. Although some Cambodian students achieved a maximum total score of 18 (90.00%), the minimum was 0.00%. This is a very wide distribution of scores that some Cambodian students gave completely wrong answers, while others could give correct answers to nearly all the questions in the assessment test.

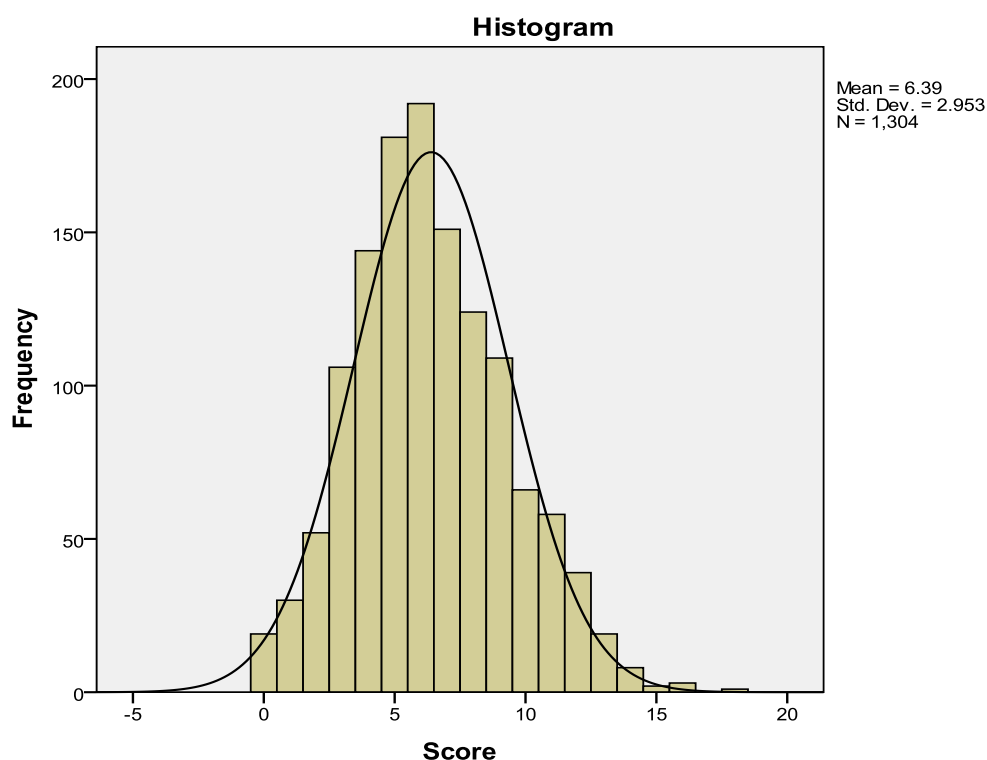

Fig. 2-1. Score distribution of Cambodian students' achievement

Table 2-2. Descriptive statistics of Cambodian students' scores

N (students)	1304
Minimum scores	0 /20 (0.00%)
Maximum scores	18/20 (90.00%)
Mean	6.39 (31.95%)
Std. Deviation	2.953

The results also show that there was not a significant difference in performance between male students (N=613, M (Mean scores)=6.34, SD=3.044) and female students (N=690, M=6.44, SD=2.873); $p=0.537>0.05$. On the other hand, the students from the districts (N=655, M=6.56, SD=2.971) seemed perform the test slightly better than those from the towns (N=649, M=6.28, SD=2.928); $p=0.043<0.05$. However, their mean scores did not show big difference. This indicates that the students have received the similar teaching and

learning opportunity in Cambodian schools in terms of curriculum, contents and materials as well as the way of learning in the classroom.

Fig. 2-2 shows the number of students in percentage that responded the correct answer by item comparing amongst Cambodia, Japan, Thailand, Malaysia, Indonesia and the ASEAN and International averages. The results show that, with the exception of Japan, the students from participating countries performed lower on the TIMSS assessment test than the ASEAN and international averages. Less than 50% of the students from the countries involved gave the correct answers to most of the test items. Cambodian student's achievement was comparable to those of Thailand, Malaysia and Indonesia, however, they were all still below the ASEAN and international averages.

Similar result was shown in summary in **Table 2-3**. The number of Cambodian students, on average, who responded with the correct answers amongst the 18 question items in total compared to those of Japanese, Thai, Malaysian, Indonesian students, as well as the ASEAN and international averages. The number of Cambodian students who were able to understand the concepts of chemistry presented by the TIMSS items was only 34.42%, much below 50%, while the TIMSS 2011 result was 59.67% for Japanese students, 40.90% for the ASEAN and 47.50% for the international average.

However, the results show that Cambodian students (34.42%) performed somewhat better than Indonesians (27.89%), though slightly below Thai (36.83%) and Malaysian students (36.94%). Japanese students showed the top performance among the comparison countries and were even higher than the international average.

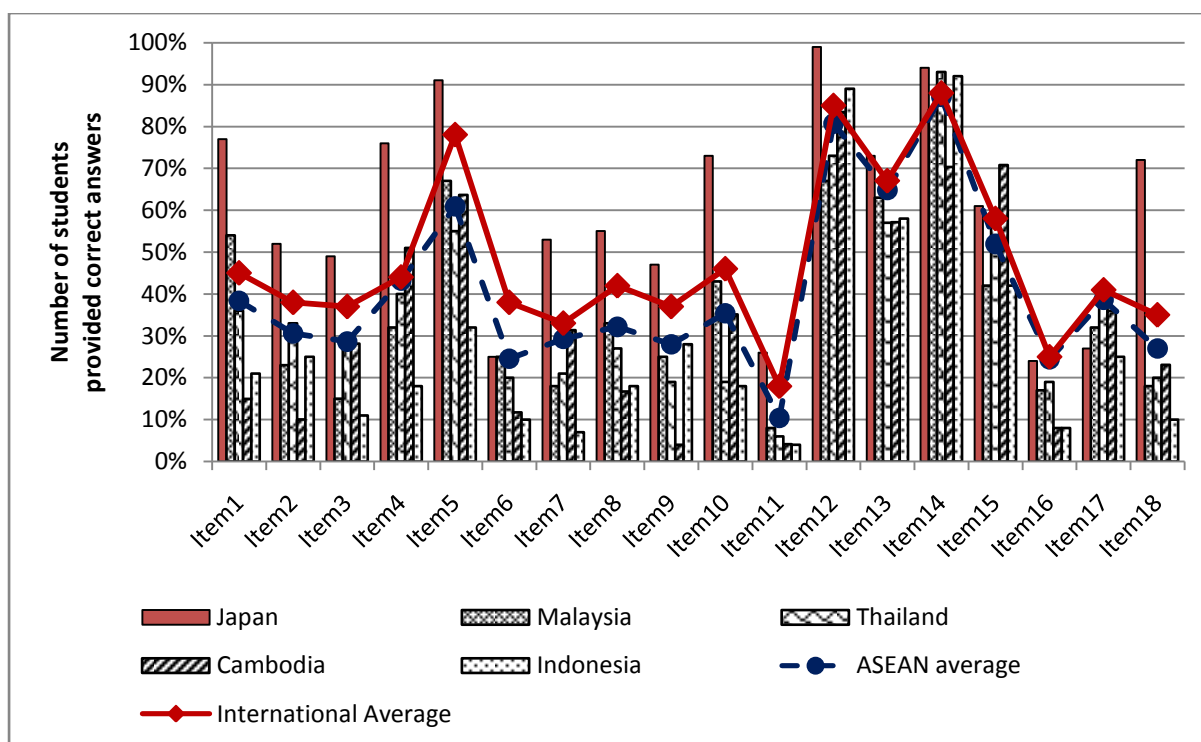

Fig. 2-2. Students performed the correct answers by question item and by country

Note : Data of Japan, Thailand, Malaysia, Indonesia, and the International average of the 18 items collected from TIMSS 2011 results.

Table 2-3. Number of students performed correct answers in summary

Countries	Minimum Number (%)	Maximum Number (%)	Average Number (%)
Cambodia	4.00	83.00	34.42
Thailand	6.00	93.00	36.83
Malaysia	8.00	84.00	36.94
Indonesia	4.00	92.00	27.89
ASEAN	5.50	88.00	40.90
International	18.00	88.00	47.50
Japan	24.00	99.00	59.67

<Properties of Matter>

The three items (items No.1, 6 and 13 as shown in Table 1), which were all multiple-choice questions, were designed to investigate the students' understanding of this concept. As seen in **Table 2-4**, many Cambodian students could not respond with the correct answers on the test. Only 27.94% of the students in average, which was the smallest number amongst the comparison countries could understand the concept of properties of matter as presented by the TIMSS items. Even though this number was slightly below Indonesia (29.67%), this

result was clearly below Japan, Thailand and Malaysia as well as the ASEAN and the International averages.

Table 2-4. Number of students performed correct answers in the properties of matter

Countries	Minimum Number (%)	Maximum Number (%)	Average Number (%)
Cambodia	12.00	57.00	27.94
Thailand	20.00	57.00	37.67
Malaysia	25.00	63.00	47.33
Indonesia	10.00	58.00	29.67
ASEAN	25.00	65.00	42.67
International	38.00	67.00	50.00
Japan	25.00	77.00	58.33

<Classification and Composition of Matter>

The ten question items were designed to test understanding of classification and composition of matter. Among those, eight items (items No. 3, 4, 8, 10, 12, 15, 16 and 17) were multiple-choice questions and two items (items No. 7 and 18) were constructed response questions. In this topic area, Cambodian students showed slightly better understanding than those of Thailand, Malaysia and Indonesia. However, the number was still below 50% and still below the Japanese, ASEAN and international averages. As seen from **Table 2-5**, 38.36% of Cambodian students gave the correct answer to the question items in this topic area while 34.40%, 31.70% and 24.60% of students for Thailand, Malaysia and Indonesia respectively. In this concept category, Japan was still at the top number and even higher than the ASEAN and international averages.

Table 2-5. Number of students performed correct answers in the classification and composition of matter

Countries	Minimum Number (%)	Maximum Number (%)	Average Number (%)
Cambodia	8.00	83.00	38.36
Thailand	19.00	73.00	34.40
Malaysia	15.00	67.00	31.70
Indonesia	7.00	89.00	24.60
ASEAN	24.00	81.00	39.10
International	25.00	85.00	44.60
Japan	24.00	99.00	58.90

<Chemical Change>

The five questions items were designed to assess students' understanding of the concept of chemical change. Among those questions, two were multiple-choice questions (items No. 5 and 14), while the other three were constructed response questions, which require students to write answers (items No. 2, 9 and 11). Cambodian students continued to show low achievement in the concept of chemical change. As shown in **Table 2-6**, only 30.43% of the students could understand and give correct answers in this topic area. This is again the smallest number amongst the comparison countries and was below the ASEAN (43.40%) and international averages (51.80%), while Japan was still at the top number and higher than the international average.

Table 2-6. Number of students performed correct answers in the Chemical change

Countries	Minimum Number (%)	Maximum Number (%)	Average Number (%)
Cambodia	4.00	70.00	30.43
Thailand	6.00	93.00	41.20
Malaysia	8.00	84.00	41.40
Indonesia	4.00	92.00	36.20
ASEAN	10.00	87.00	43.40
International	18.00	88.00	51.80
Japan	26.00	94.00	62.00

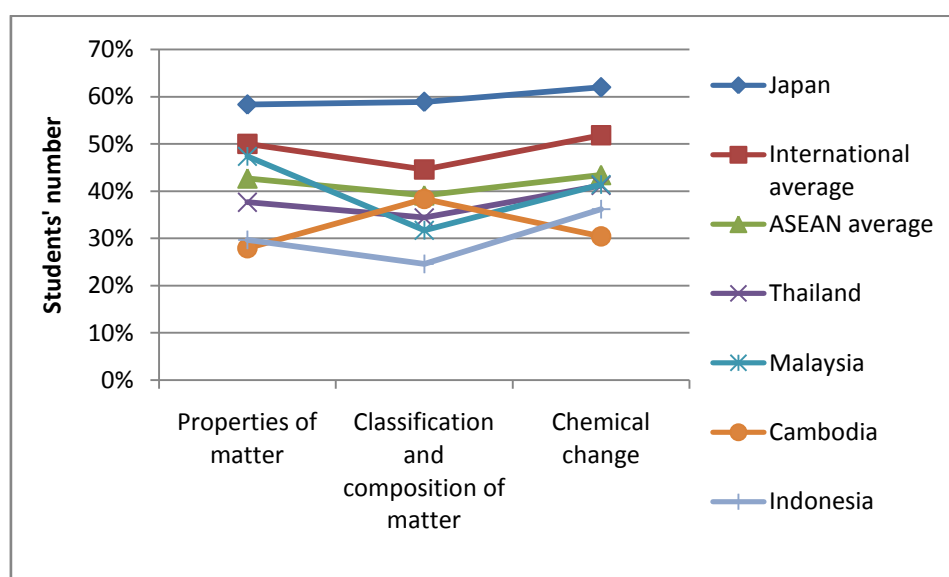

Fig. 2-3. Summary of students' achievement in the content domain

The Cambodian students' achievement amongst the three concept areas in the content domain compared with ASEAN and the international averages is summarized in **Fig. 2-3**.

2. Students' performances in the Cognitive Domain

In general, the performance in the cognitive domain of students in all comparison countries followed the same pattern, as seen in **Fig. 2-4**, and this was reflected in the ASEAN and the international averages. The highest achievement was in knowing scientific knowledge, followed by reasoning and then applying scientific knowledge. Amongst these countries, Japanese students displayed the highest ability in all cognitive domains, and ranked even higher than the international and ASEAN averages. The achievement of other countries was in decreasing order, Malaysia, Thailand, Cambodia and Indonesia.

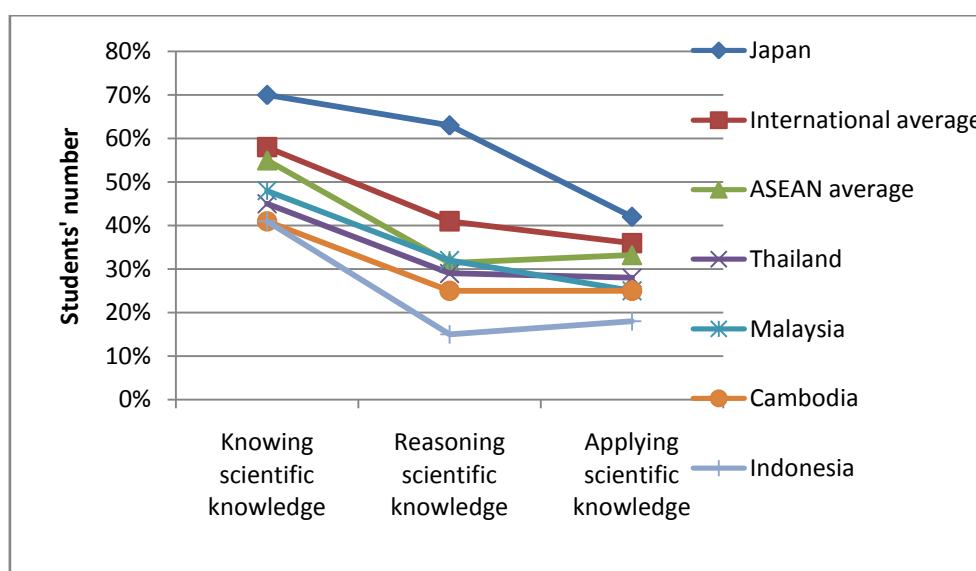

Fig. 2-4. Summary of students' achievement in the cognitive domain

<Knowing Scientific Knowledge>

Table 2-7. Number of students performed well in knowing scientific knowledge

Countries	Minimum Number (%)	Maximum Number (%)	Average (%)
Cambodia	4.00	83.00	46.67
Thailand	19.00	93.00	49.29
Malaysia	18.00	84.00	51.00
Indonesia	7.00	92.00	46.29
ASEAN	28.00	87.00	54.71
International	33.00	88.00	61.43
Japan	47.00	99.00	73.14

The seven question items on the assessment test (items No. 5, 7, 8, 9, 12 and 13) were designed to measure the extent of students' knowing scientific knowledge as shown in Table 1. Cambodian students' knowledge in science was below the comparison countries and the ASEAN and international averages. From **Table 2-7**, Cambodian and Indonesian students have similar weaknesses in this cognitive domain as only 46.67 % of Cambodian students and 46.29% of Indonesian students could respond with correct answers, while Japanese, Malaysian and Thai students had 73.14%, 51.00% and 49.29% respectively.

<Reasoning Scientific Knowledge>

Table 2-8. Number of students performed well in reasoning scientific knowledge

Countries	Minimum Number (%)	Maximum Number (%)	Average Number (%)
Cambodia	12.00	51.00	25.19
Thailand	20.00	40.00	29.00
Malaysia	18.00	54.00	32.25
Indonesia	10.00	21.00	14.75
ASEAN	25.00	43.00	33.25
International	35.00	45.00	40.50
Japan	25.00	77.00	62.50

Four question items (item No. 1, 4, 6 and 18) were included in the test to understand the students' skills in reasoning scientific knowledge. One of the item was a constructed response question (item No. 18). As seen in **Table 2-8**, only 25.19% of Cambodian students could give appropriate reasons for the scientific concepts presented in the test. Although this was slightly higher than the Indonesia, it was lower than other regional countries, Thailand and Malaysia as well as the ASEAN average. Compared to Japan and the international average, Cambodia was even further behind.

<Applying Scientific Knowledge>

Seven question items were presented to assess the skills of applying scientific knowledge (items No. 2, 3, 10, 11, 15, 16 and 17), in which two (items No. 2 and 11) were constructed response questions, as seen in **Table 1**. In this skill domain, Cambodian students' performance was similar to regional comparison countries. They performed slightly better

than Indonesian and Malaysian students, but were slightly below Thai students as seen in **Table 2-9**. However, this result was again below the ASEAN and international averages and Japan.

Table 2-9. Number of students performed well in applying scientific knowledge

Countries	Minimum Number (%)	Maximum Number (%)	Mean Number (%)
Cambodia	4.00	71.00	27.46
Thailand	6.00	59.00	28.86
Malaysia	8.00	43.00	25.71
Indonesia	4.00	25.00	19.00
ASEAN	10.00	52.00	31.43
International	18.00	58.00	37.57
Japan	24.00	73.00	44.57

VI. IMPLICATIONS FOR CAMBODIAN CONTEXT

In general, Cambodian student showed similar performance in chemistry competency amongst males and females as well as towns and districts. However, their achievement was low compared to that of the regional comparison countries on the TIMSS assessment items. Only Indonesia was lower in both concept and cognitive domains. Cambodian students were significantly below the ASEAN and the international average in both content and cognitive domains.

The following is a discussion of the implications of the research results for the current Cambodian science education context. The discussion focuses on the greatest weaknesses of Cambodian student achievement in each domain in order to magnify the problems in the current Cambodian education context.

1. The Content domain

As shown in the research results in the content domain, Cambodian students achieved an overall third position amongst the four regional comparison countries, behind those of Malaysia and Thailand, and above Indonesia. Cambodian students achieved below the ASEAN and international averages and significantly behind those of Japan. In the specific

content areas, Cambodian students showed better than average achievement in the Classification and Composition of Matter, scoring higher than all its regional neighbors (**Fig. 2-2**), but still lower than the ASEAN and international averages and Japan. However, Cambodian students scored lowest in the region in the areas of Properties of Matter and Chemical Change.

For instance, in the concept area of the properties of matter, only a few Cambodian students could respond with the correct answers to the assigned items (No. 1, 6 and 13), as shown in **Fig.2-3**. Question item No.1 assesses the students' understanding of the change in solubility of sugar with temperature by asking them to choose an appropriate solubility graph. Only 15% of students who participated in the test could explain that the dissolved amount of sugar in water increased when the temperature increased. In the case of question item No. 6, which requires students to select the property of water that has the most effect on splitting a rock into two pieces, only 12% of them could choose the correct statement, "water expanding when it freezes." Question item No. 13 asks the students to choose the correct term used to describe the process that occurs when ammonia solution is added to a red colored solution of vinegar until the color disappears. The 57% of Cambodian students could choose the right answer explaining that this process is called "neutralization", and this result is similar to the students from regional countries like Thailand, Malaysia and Indonesia.

It should be noted that the concept of properties of matter exists in the current Cambodian lower secondary school curriculum from 7th grade throughout to 8th grade (MoEYS, 2011& 2013). But the concept of solubility of matter in water is described very briefly, only as a definition in Grade 8, and the change in solubility is never shown graphically. Therefore, the students may have had difficulty understanding the meaning of the scientific data expressed in the graph. Similarly, the properties of water are also discussed in both the 7th and 8th Grade textbooks. However, the content focuses on the changes of water

between solid, liquid and gas states, the water cycle and water composition, while the concept of the volume of water expanding when it becomes solid (ice) is not discussed. Therefore, the power of water to break a stone into small pieces by volume expansion when it freezes, as described in the test, is not a familiar one with Cambodian students. Moreover, the concept of acid-base is not introduced in 7th nor 8th grades, but in the 9th grade (MoEYS, 2012) and the changes in color of acid-base indicators, as described in the test item, is not discussed until the upper secondary level in 11th grade. Therefore, it might be difficult for Cambodian students to understand these concepts.

While Cambodian student achievement was relatively better than regional comparison countries in the concept area of the classification and composition of matter, they had lower performance in the concept area of chemical change. Less than 10 % of the students answered correctly to the three question items among the five in the area of chemical change. The three questions are items, No. 2, 9 and 11, as seen in Figure 2, are constructed response questions. The question item No. 2 requires students to write an explanation of the reason why a balloon inflates when sodium bicarbonate is mixed with vinegar. Only 10% of the students could write an appropriate explanation by using correct terms such as “the balloon inflates because of the carbon dioxide gas or gas is released from the reaction between the sodium bicarbonate and the vinegar.” In the case of questions No. 9 and 11, only 4% Cambodian students could give correct answers to each. This is a very low performance. The question item No. 9 asks students to describe two pieces of evidence that could be observed when a chemical reaction is taking place, while question No. 11 asks students to give evidence to show that energy is released during a chemical reaction.

The content covered in these test items is more practical and not simply recall of knowledge. Looking at the content in the Cambodian textbooks, the concept of chemical change is introduced from 7th grade through 8th grade. However, only a few chemical

reactions are discussed theoretically and abstractly, such as burning a candle or charcoal, combustion of some metals like copper and magnesium, reaction of iron powder and sulfur powder, and the reaction of hydrogen with oxygen. The discussion also has little linkage with daily life and materials. There is neither the reaction of vinegar with carbonate, nor any discussion of the release or absorption of heat from the reaction. Moreover, Cambodian students have little or no opportunity to observe chemical change phenomena in the classroom as already mentioned from a previous survey in the introduction and background of this paper. Therefore, the question items in this concept area are again beyond the Cambodian students' capacity and are not familiar to them. This may help to explain their low achievement in this conceptual area.

Following the above discussion, it can be seen that the chemistry content in the current Cambodian curriculum and textbooks does not meet an international assessment level, as assessed by TIMSS, especially the topic area of properties of matter and chemical change. Much of the content in TIMSS does not exist in the Cambodian textbooks at this level. This finding is in accordance with previous research which has reported that the current Cambodian science curriculum and textbooks are lacking in content and links with familiar materials and real phenomena in daily life, and also that the content which is present is too theoretical and abstract (Morimoto, & Maeda, 2002; Maeda, Pen, Set, Kita & Sieng, 2006; Sieng, Atsushi & Takeshi, 2006; Buccella, Ozturk & Pritt, 2013; Thlang, 2013 and NIE, 2013).

Therefore, the current Cambodian curriculum and textbooks for science should be reviewed and revised to enrich content to meet regional and international standards.

2. The cognitive domain

As seen in **Fig.2-4**, Cambodian students have lower performance in the cognitive domain than regional countries Thailand and Malaysia, though slightly higher than Indonesian students. The largest differences in cognitive skills between Cambodian students

and their regional counterparts were in applying and reasoning scientific knowledge. This result is significant because these two skills are very important to develop students' scientific process skills. Harlen (1999) and Karsli&Sahin (2009) suggest that both students and educators need science process skill to understand and interpret the natural phenomena surrounding them, because scientific processes are inseparable from the conceptual understanding involved in learning and applying scientific knowledge. However, these skills appear to be relatively low in the current generation of Cambodian students.

The question items assigned to assess the students' competencies in the areas of applying and reasoning scientific knowledge are not only based on knowledge, but more on practice. Students who have been exposed to practical work in science are more likely to be able to answer correctly on this kind of test items. For instance, question item No. 1 asks students to choose the most reasonable graph to express the change in solubility of sugar in water with temperature; No. 2 asks students to write an explanation giving the reason why a balloon inflates; Item No. 11 asks students to describe evidence that could be observed when a chemical reaction releases heat; Item No. 16 asks students to apply the concepts of element, compound and mixture to everyday materials such as air, salt, sugar, gold, sea water and helium; and item No. 18 asks students to write an appropriate sentence to tell how to identify matter as a metal.

Students would have difficulty answering such questions unless they were familiar with scientific observations through real experiment or demonstration in the science classroom, which is rare in Cambodia. It is therefore not so surprising that on average only 25.19% and 27.46% of Cambodian students respectively, demonstrated adequate skills of reasoning and applying scientific knowledge, as seen in Table 7 and 8. Although the differences between regional countries seem small in this domain, they are still significantly below the ASEAN and International averages as well as Japan.

VII. CONCLUSION AND SUGGESTION

These results clearly imply that the current science education in Cambodia does not promote enough the students' scientific skills in the classroom. They might be influenced by several factors in the current Cambodian context as reviewed by the previous researches, such as lack of appropriate teaching content, teaching and learning materials and science teacher competency.

Following these findings, it can be recommended that science education in Cambodia should pay increased attention to the reform of science content and ways of teaching together with available teaching materials in order to encourage and provide students with enough opportunities to explore scientific practical work in classroom. At the same time, the competency improvement of science teacher should also be more concentrated through offering in service training program to strengthen them with science content, practical work and effective science teaching skills. Therefore, the students would have more opportunity to practice their scientific skills and analysis skills to interpret unfamiliar problems or phenomenon by using their knowledge to provide an appropriate scientific explanation. Murphy & McCormick (1997) suggest that practice is the key to developing good problem solving skills which can sharpen many scientific skills at the same time, such as the skills of observation, questioning, data collection, data analysis, data interpretation, reasoning, drawing conclusions and so on. Besides real practice in science lessons like experiments or demonstrations, several effective teaching methods and materials can also be used to help students to visualize abstract theory. For example Huddle, White, and Rogers (2000) suggested the use of teaching models to draw students from scientific misconception in South Africa, and Sanger and Greenbowe (2000) suggested the use of computer animations depicting chemical reactions at the molecular level to construct students' visual understanding of chemistry.

Although this research is focused on only a single science subject, chemistry is a central science and encompasses the basics of reasoning and applying knowledge; the higher order cognitive skills that are considered necessary in a modern knowledge based economy. Cambodia will soon need to compete on an almost even playing field with its regional neighbors in 2015 after ASEAN integration so its relative position will become increasingly important. The results of this research suggest that Cambodia is significantly below most of its regional neighbors in these basic thinking skills and so will need to focus on reform of science education in order to compete. With the current context of Cambodia, development of teaching and learning materials from simple and available ones in daily life could effectively help to improve science education in this country. Therefore, the following chapters will introduce several developments of such useful teaching and learning materials.

"Science is a way of thinking much more than it is a body of knowledge"

(Carl Sagan, 2014).

REFERENCES

- Bandura, A. (1989). Human agency in social cognitive theory. *American Psychologist*, 44(9), 1175-1184.
- Bucat, Bl, &Fensham, P. (1995). Selected papers in chemistry education research implications for the teaching of chemistry. *Delhi: Shatabdi Computer*.
- Buccella. A, Ozturk.B,&Pritt. A. (2013). A Baseline Evaluation on Curriculum Analysis, Resource Availability and Interests in STEM Field among Students and Teacher. *Caring for Cambodia Report*, Lehigh University, USA.
- Chantha, C. (2013). Examination of science process skills of elementary teacher trainees in PTTCs in Cambodia. *Master Thesis*, Hiroshima University, Japan
- Clayton, Tl, &Ngoy, Y. (1997). Asia Higher Education: An International Handbook and Reference Guide. (G. A. Postiglione, & G. C. Mak, Eds.) New York, USA: Gerard A. Postiglione and Grace C. L. Mak.
- Gabel, D.L.k&Bunce, D.M. (1994). Research on problem solving. In D. Babel (Ed), Handbook of research on science teaching and learning. New York: Macmillan, 301-326.
- Garnett, P.J., Garnett, P.J., & Hackling, M. W. (1995). Students alternative conceptions in chemistry: A review of research and implications for teaching and learning. *Studies in science education*.25, 69-95.
- Ginns, I. S., & Watters, J. J. (1995) An analysis of scientific understanding of pre-service elementary education students.*Journal of research in science teaching*, 32(2), 205-222.
- Griffiths, A.K. (1994). A critical analysis and synthesis of research on students' chemistry misconceptions.In H.-J. Schmidt (Ed.), Problem solving and misconceptions in chemistry and physics, Hong Kong: ICASE, 70-99.

- Hannus, J; Hamilton.S; Russell. J. S. (2008). The Cognitive and Affective Domain in Assessing the Life-Long Learning Objective.*American Society for Engineering Education*.AC2008-72.
- Hans-J.S., Annette. M., & Allan.G.H. (2007). Factors that prevent learning in electrochemistry.*Journal of Research in Science Teaching*, 44 (2), 258-283.
- Harlen, W. (1999). Purpose and Procedure for Assessing Science Process Skills. *Assessment in Education: Principles, Policy & Practice*, 6(1),129-144.
- Huddle, P. A., White, M. D., & Rogers, F. (2000). Using a teaching model to correct known misconceptions in electrochemistry. *Journal of Chemical Education*, 77(1), 104-110.
- Johnstone A.H. (2000). The presentation of chemistry - logical or psychological?*Chemistry Education: Research and Practice in Europe (CERAPIE)*,1, 9-15.
- Johnstone.A.H. (1982). Macro and microchemistry.*School Science Review*,64, 377-379.
- Johnstone.A.H. (1991). Thinking about thinking.*International Newsletter on Chemical Education*, 6, 7-11.
- Karsli, F., &Sahin, C. (2009). Developing worksheet based on science process skills: Factors affecting solubility. *Asia-Pacific Forum on Science Learning and Teaching*, 10(1), p. 1.
- Maeda, M.(2003) RUPP Chemistry Student Survey Report, STEPSAM.
- Maeda, M., Pen, S., Set, S., Kita, M., &Sieng, S. (2006). The quality of science teachers in Cambodia: From Problem to a Solution. HCMC: IRD-IER-NIESAC.
- Mann. J.(2011). Hand Book: Chemicals for life and living, EiichiroOchiai, Heidelberg, Germany: Springer.
- McGinn, M. K., & Roth, W.-M. (1999). Preparing students for competent scientific practice: Implications of resent research in science and technology study.*Journal of Education Research*, 28(3), 14-24.
- MoEYS. (1998). *Base Line Study Science and Mathematics Education of Cambodia*, PMMU

- MoEYS. (2004). Policy for curriculum development 2005-2009. Ministry of Education, Youth and Sport, Phnom Penh, Cambodia.
- MoEYS. (2011). Science Textbook-Grade 7. Ministry of Education, Youth and Sport (MoEYS). *Printing House/MoEYS, Cambodia*
- MoEYS. (2012). Science Textbook-Grade 9. Ministry of Education, Youth and Sport (MoEYS). *Printing House/MoEYS, Cambodia.*
- MoEYS. (2013). Science Textbook-Grade 8. Ministry of Education, Youth and Sport (MoEYS). *Printing House/MoEYS, Cambodia.*
- Morimoto, K. & Maeda, M. (2002). Analysis of upper secondary biology textbook in Cambodia. *International Journal of Curriculum Development and Practice*, 4 (1), 31-38.
- Murphy, P., & McCormic, R. (1997). Problem Solving in Science and Technology Education. *Research in Science Education*, 27(3), 461-491.
- Neth, B & Wakabayashi, M. (1999). *Science and Mathematics Teacher Education Through Cambodian Higher Education System*, GSID, Nagoya University.
- NIE. (2013). Secondary School Science Curriculum: View points from science teachers and students. Research Report of Ministry of Education Youth and Sport (MoEYS)/National Institute of Education (NIE).
- PISA. (2013). Programme for International Student Assessment (PISA): PISA 2012 Results in Focus, What 15-year-olds know and what they can do with what they can know. OECD.
- Rahayu, S & Kita, M. (2010). An analysis of Indonesian and Japanese students' understandings of macroscopic and submicroscopic levels of representing matter and its change. *International Journal of Science and Mathematics Education*, 8 (4), 667-688.
- Sanger, M. J., and Greenbowe, T. J. (2000). Addressing student misconceptions concerning electron flow in aqueous solutions with instruction including computer animations and conceptual change strategies. *International Journal of Science Education*, 22(5), 521-537.

- Sieng, S, Atsushi. Y, Takeshi. N. (2006). A comparative study between the current Cambodia's upper secondary school chemistry textbooks and that of Singapore, the United state and the United Kingdom, *Bulletin of Aichi University of education research and practice center*, 9, 185~194
- STEPSAM2. (2009). Baseline Survey Report. Cambodian Science Teacher Education Project. PADECO CO., LTD & HIROSHIMA University.
- Thlang, S. (2013). Analysis of Cambodian high school chemistry textbook. Master Thesis, Hiroshima University, Japan.
- TIMSS. (2011). Trends in International Mathematics and Science Study(TIMSS): *TIMSS 2011 Assessment and/or PIRLS 2011 Assessment. Copyright © 2013 International Association for the Evaluation of Educational Achievement (IEA). Publisher: TIMSS & PIRLS International Study Center, Lynch School of Education, Boston College, Chestnut Hill, MA and International Association for the Evaluation of Educational Achievement (IEA)*
- UNESCO (2001). *Final Report on Science Education in Cambodia*, A Joint MoEYS/UNESCO Science Education Assessment.
- UNESCO. (1991). Inter-sectoral Basic Needs Assessment Mission to Cambodia. Bangkok, Thailand: UNESCO.
- Wall, S. V., Uon, V, Cnudde, V., &Keo, M. (2010). Strengthening student centered approaches in science teaching in Cambodia. VVOB, Cambodia.
- Watters, J. J., Ginns, I. S. (2000). Developing motivation to teach science: Effect of collaborative and authentic learning practices in pre-service education. *Journal of Science Teacher Education*, 11(4), pp.277-313.

Chapter III

DEVELOPMENT OF TEACHING MATERIALS FOR LESSONS ON DETERGENT

I. DETERGENT

Detergents are Surfactants (surface-active agents). They are popular and important chemicals involved in daily use as well as in laboratory research both for chemistry and biology. In general, detergents have common physical and similar chemical properties to soap. Their molecules are composed of two parts (**Fig. 3-1 A**). The “*Head*” part is polar (usually ionic) and is “*hydrophilic*” as it has an affinity for water. The “*Tail*” part is the other end of the molecule with a long-chain hydrocarbon which is “*Hydrophobic*” as it is relatively insoluble in water. A detergent molecule differs from a soap molecule at its head. The head of a soap molecule is a carboxylate anion ($-\text{COO}^-$) that is generally a sodium salt of a fatty acid made from the reaction between fatty acid and sodium hydroxide. But the head of detergent is composed of a sulfonate anion ($-\text{SO}_3^-$) that is generally made by esterification or sulfonation of a long chain alcohol with sulfuric acid, and then neutralized by sodium hydroxide. Another important difference is that soap is a basic compound that gives a precipitate in hard water, which causes soap to lose its ability for cleaning or washing. But detergent can work well, without precipitation, even if in hard water. Therefore, detergent acts as a better cleaner than soap to remove dirt. Because of this, detergent is commonly used for cleaning and washing rather than soap. However, it is difficult to prevent the impact of detergent on human health and the natural environment due to its very slow molecular degradation and therefore long life in the environment (**Table 3-1**).

When adding soap or detergent to water, their molecules quickly spread on the water surface forming a monomolecular layer, because of their hydrophobic tails (**Fig 3-1 B**). Therefore, it significantly lowers the interaction of water molecules on the surface and makes it easier to wet and to pass through the surface of fabrics to be cleaned. For these reasons, soaps and detergents are often called **surfactants** or surface-active agents. Within the water, the molecules of soap or detergent gather together to form *micelles* and *membranes*; little

aggregates of molecules united by their own hydrophobic tails or most often they lock pieces of dirt inside the micelles (**Fig 3-1 B**).

When they meet dirt, these molecules surround the dirt particles fixing their hydrophobic tails into them. The hydrophilic heads pull the dirt toward water. Such interaction contributes to removing the dirt from the fabric with the agitation of the liquid (**Fig 3-1 C**). The lowering of the water molecule interaction on the surface also allows the formation of soapy membranes, foam and soap bubbles.

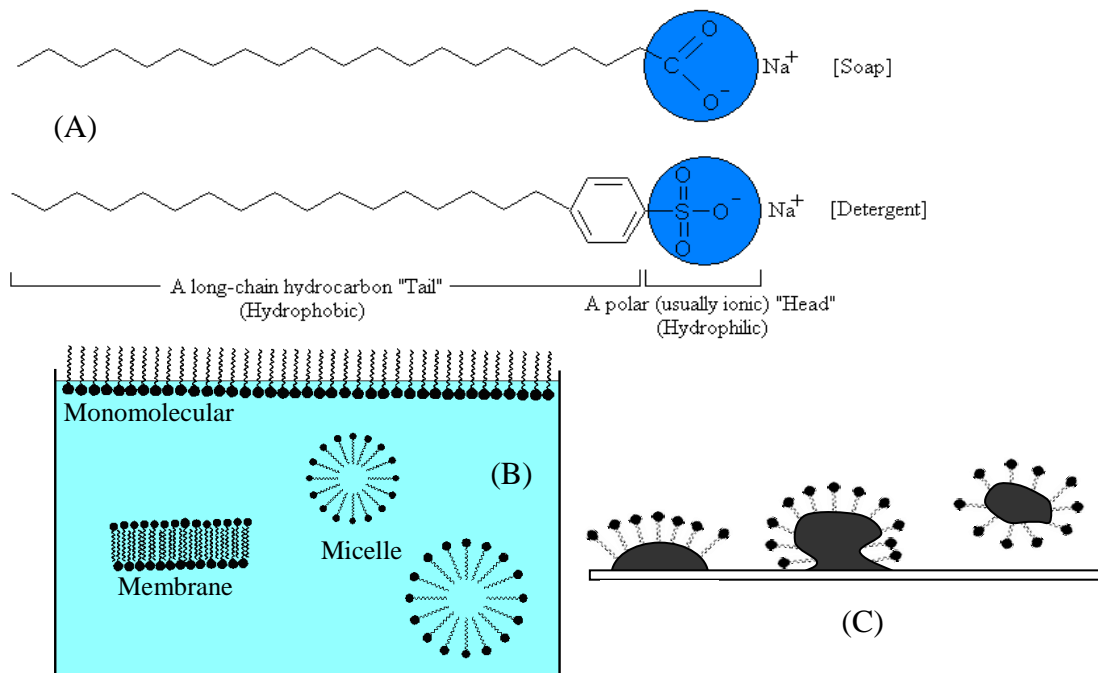

Fig. 3-1: Surfactants: (A) Surfactant molecules, (B) formation of monomolecular layers, membranes and micelles in water; and (C) the way they remove the dirt.

Table 3-1: Some types of detergent in daily use

Detergent type	Compound name	Acronym
Anion	Sodium <u>A</u> rufa- <u>S</u> ulfo <u>F</u> atty acid Ester	ASF
	Sodium <u>L</u> inear <u>A</u> lkyl Benzene <u>S</u> ulfonate	LAS
	Sodium <u>A</u> lkyl <u>S</u> ulfate Ester	AS
	Sodium <u>A</u> lkyl <u>E</u> ther <u>S</u> ulfate Ester	AES
	Sodium <u>A</u> rufa- <u>O</u> lefin <u>S</u> ulfonate	AOS
	<u>S</u> odium <u>A</u> lkyl <u>S</u> ulfonate	SAS
Non-ion	<u>S</u> ucrose Fatty acid <u>E</u> ster	SE
	Sorbitan Fatty acid Ester	-
	Poly- <u>O</u> xy- <u>E</u> thylene Sorbitan Fatty acid	TWEEN
	<u>P</u> oly- <u>O</u> xy- <u>E</u> thylene Fatty acid Ester	PEG
	Fatty acid Alkanol Amido	DA
	<u>P</u> oly- <u>O</u> xy- <u>E</u> thylene Alkyl ether	POE • R
	<u>P</u> oly- <u>O</u> xy- <u>E</u> thylene Alkyl Phenol Ether	POE • P
Amphoteric ion	Sodium Alkyl Amino Fatty acid	-
	Alkyl-Betain	-

Therefore, at the same time that we enjoy using various kinds of detergent products, we should also consider how they work and the effects they have as

a result of their properties. Here, we will study the effect of detergent on the properties of water, particularly water surface tension.

II. DETERGENT ANALYSIS BY WATER SURFACE TENSION

1. Principle background

Some articles published in the Journal of Chemical Education (USA) have shown several analytical techniques for determining some physical properties of detergents. The most popular properties concerned are the formation of micelles and the ability of detergent to lower water surface tension (Kenneth G, 1993; Paul G, 1993; Ana D, 1997; Nasimul G, 2002 & Pablo C, 2003). In the case of lowering the surface tension of water, the study needs to involve a method of determination of water surface tension. The most common methods used for determination of this physical property of water are the capillary rise and drop-weight method (Meyer E, 1986; John D, 1992; H Alan, 1992 & Hideaki 1975). Even though several methods have been developed and proposed for application in the classroom, most of them are considered to be suitable for undergraduates. They are difficult to apply at the high school level because some of them require expensive apparatus, complicated procedures and a high level of analysis, and some others are only suitable for demonstration (qualitative analysis).

In the study, I tried to use simple, inexpensive apparatus, except for a balance, and easy procedures which were appropriate for high school students. Three analytical methods that are capillary action, drop weight and marbling ink were used to investigate the effect of detergent on surface tension of water.

2. Surface Tension

A common property to all liquids is their **surface tension**, which *is a force that tends to pull adjacent parts of a liquid's surface together, thereby decreasing surface area to the smallest possible size*. Surface tension results from the attractive forces between particles of a

liquid, also called “*cohesion*”. The higher force of attraction causes the higher surface tension. Water has a higher surface tension than most liquids. This is due to the hydrogen bonds between water molecules. The molecules at the surface of the water are a special case. They can form hydrogen bonds with the other water molecules beneath them and beside them, but not with the molecules in the air above them. Molecules in the surface therefore experience a net attractive force into the liquid since there are fewer particles in the gas phase above them. As a result, the surface water molecules are drawn together and toward the body of the liquid, creating a high surface tension (**Fig. 3-2**). In the case of a molecule at the interior of a medium, it is equally attracted by all neighboring molecules. The effect is that it is attracted to all sides with the same force, so that the resulting force is zero.

Surface tension causes liquid droplets to take on a spherical shape because a sphere has the smallest possible surface area for a given volume of liquid. Because of this, small objects such as a paper clip, small coin *or* small insects like water-striders, do not drown in water (**Fig. 3-3**). They are held up by surface tension of water.

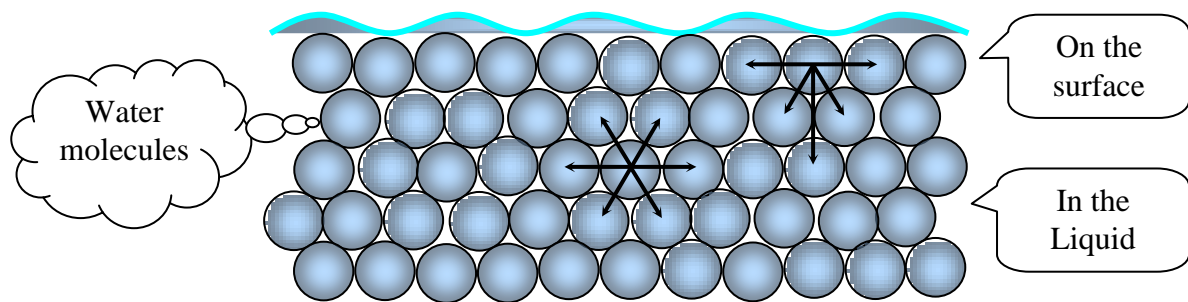

Fig. 3-2: Phenomenon of surface tension of water



Water strider

Hand-made water strider

Paper clip

Fig. 3-3: Water strider and small objects are held by water surface tension.

Adding surfactants, like detergent, into water makes the surface tension less due to changes in the surface behavior. A loss of surface tension causes small objects such as a paper clip or water strider that might have floated on the water's surface, to sink.

3. Determination of Water Surface Tension

The surface tension of pure water has been determined as 72 mN/m at 25 °C. There are two common methods to determine the surface tension of liquid, capillarity (capillary action) and drop weight.

In the case of capillary action: The tendency of liquids to rise up capillary tube (tubes of narrow bore), which is called *capillary action*, is a consequence of surface tension. The attraction of the surface of a liquid to the surface of a solid is a property closely related to surface tension. The rising up of a liquid along the edge of narrow tube is caused by a strong attraction exists between the liquid molecules and the molecules that make up the surface of the tube. This attraction tends to pull the liquid molecules up ward along the surface against the pull of gravity. This process continues until the weight of the liquid balances the gravitational force. The narrow the tube, the higher the water level will rise. The capillary action is one of methods for measuring surface tension of water by measuring the height of raised water along the capillary tube. It's noticed that in a glass tube or a glass container, water forms a **meniscus** (curved surface). The water molecules are more strongly attracted to the glass molecules than to other water molecules. So, that's why the water rises up along the wall of the capillary glass tube and forms a meniscus curving downwards (**Fig. 3-4**). Since the rising water is the consequence of water surface tension, when the water raises a lot, it means that the surface tension is big (Peter Atkins, 2002; Gordon, 1973; Walter, 1972).

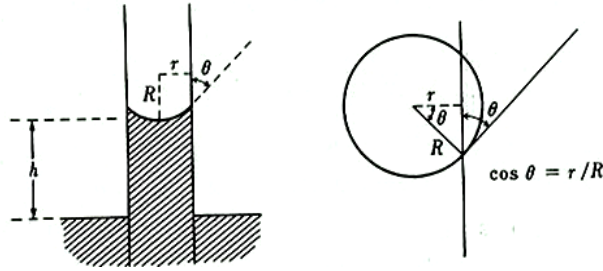

Fig. 3-4: Meniscus curve and θ angle given by capillarity

From the **Fig. 3-4**, the surface tension of liquid is calculated from the following equation.

$$\gamma = \frac{\rho g h r}{2 \cos \theta} \quad (1)$$

Where γ is surface tension (mN/m), ρ is sample density (kg/m^3), h is raised height of liquid along the column (m), r is radii of capillary glass tube (m) and θ is angle given by meniscus curve as shown in **Fig. 3-5**.

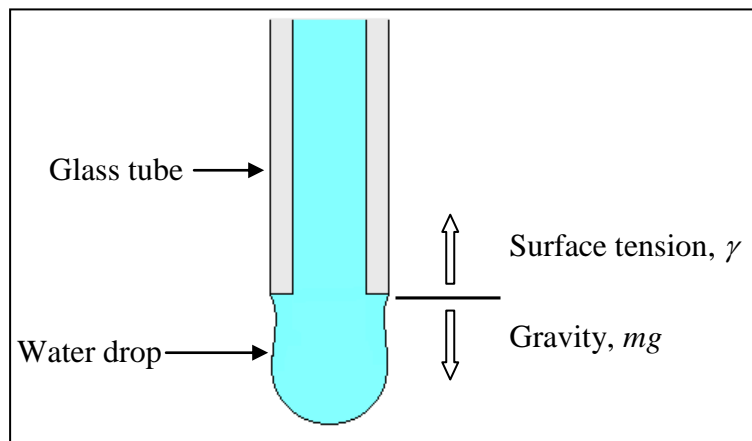

Fig. 3-5: The Opposition between water surface tension and gravity on a water drop

In the case of drop weight: when water is dropped from a glass tube, there are two opposition forces. The surface tension of water tends to hold up the water drop within the glass tube, whereas gravity tries to pull the drop downward to drop out of the glass tube. The stronger the surface tension, the heavier the drop and the larger the drop size (Hideaki, 1975).

$$\gamma = \frac{mg\phi}{2\pi r} \quad (2)$$

Where m is mass of one water drop (g), g is universal gravity (9.81 m/s^2); r is the outside radius of glass tube (m) and ϕ is a correction factor that is a function of $\frac{r}{\sqrt[3]{V}}$, their values are shown in **Table 3-2**. The volume of one water drop V may be calculated from the drop mass and liquid density.

Table 3-2: Variation of the correction factor ϕ with $\frac{r}{\sqrt[3]{V}}$

$\frac{r}{\sqrt[3]{V}}$	ϕ	$\frac{r}{\sqrt[3]{V}}$	ϕ	$\frac{r}{\sqrt[3]{V}}$	ϕ
0.00	1.0000	0.70	1.6412	1.15	1.5608
0.30	1.3780	0.75	1.6578	1.20	1.5302
0.35	1.4263	0.80	1.6667	1.225	1.5255
0.40	1.4645	0.85	1.6688	1.25	1.5335
0.45	1.4994	0.90	1.6672	1.30	1.5622
0.50	1.5349	0.95	1.6572	1.35	1.6051
0.55	1.5718	1.00	1.6398	1.40	1.6575
0.60	1.6000	1.05	1.6183	1.45	1.7102
0.65	1.6205	1.10	1.5923	1.50	1.7627

Note: The numerical data in this table is originally quoted from "Hideaki Chihara ed., 1975."

4. Determination of effect of detergent on water surface tension by capillarity

<Materials>

Only simple apparatus was used in this experiment, such as capillary glass tubes (1.12 cm diameter), a ruler which could be read in millimeters, transparent tape and 50 mL beakers or transparent plastic cups.

The experiment examined 6 samples, of which one was pure water. The other five samples were prepared from a commercial detergent (Family, KAO brand, made in Japan),

which contained 22% of surfactant, in different concentrations as follows: 0.50 g of the above commercial detergent was weighed and diluted in a 1 L measuring flask. Then, this detergent solution was diluted to twice the volume in a series until 5 samples were obtained. Therefore, each sample contained the commercial detergent in the concentration of 0.05% w/v, 0.025% w/v, 0.0125% w/v, 0.00625% w/v and 0.003125% w/v respectively.

<Procedure>

A capillary glass tube was fixed onto a transparent ruler with tape, and the bottom of the tube adjusted to be under the zero graduation of the ruler (**Fig. 3-6**). The attached capillary tube, with the ruler, was then dipped into pure water. The increase in height of the water up the tube was recorded. The same procedure was used for the other detergent samples with a new capillary tube for each sample.

<Hazards>

No chemicals or procedures used by students cause any significant hazards in this experiment.

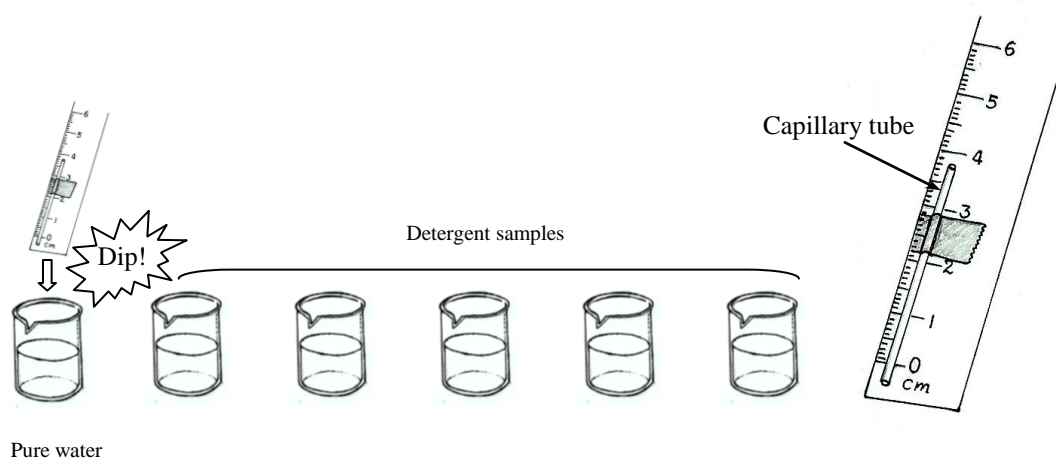

Fig. 3-6: Experimental setup for capillarity

<Result and discussion>

The tendency of liquids to rise up a glass capillary tube, which is called *capillary action* or *capillarity*, is a consequence of surface tension. The water rose up the capillary tube when it first touched water because it has a tendency to adhere to the glass walls (See Fig. 3-4). The adhesion between the water and the glass causes the water to rise up the glass if the tube is narrow enough. The narrower the tube, the higher the water level will rise.

In contrast, when the pure water was replaced by detergent solution, the heights of solution in the capillary tube decreased drastically with the concentration of detergent as shown in **Fig. 3-7**. This clearly implies that the surface tension of the water was diminished by the detergent.

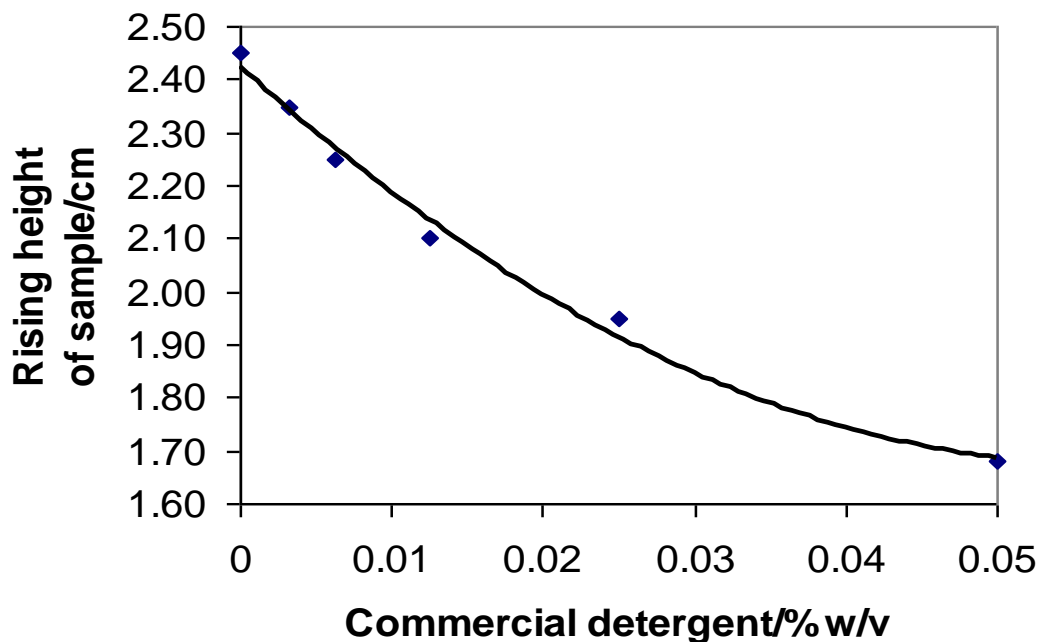

Fig. 3-7: The decrease in height of raised water in the capillary with different detergent concentrations

Capillary action is much related to our lives. Capillary action is important for moving water around (and all of the things that are dissolved in it). It is defined as the movement of water within the spaces of a porous material due to the forces of adhesion, cohesion, and

surface tension. Capillary action occurs because water is sticky. Water molecules stick to each other and to other substances, such as glass, cloth, organic tissues, and soil. Dip a paper towel into a glass of water and the water will "climb" onto the paper towel. In fact, rising water will keep going up the towel until the pull of gravity is strong enough for it to overcome.

5. Determination effect of detergent on surface tension by drop weight

<Materials>

The following describes the necessary materials used in this determination. A 50mL Erlenmeyer flask was used to collect the sample drops. A rubber stopper fitted with an L-shaped glass tube (inner diameter: 3mm and outer diameter: 5 mm) and another straight glass tube about 10 cm long, was fitted into the mouth of the Erlenmeyer flask. The short glass tube was necessary to remove air while dropping the sample. This apparatus was connected to a 1 mL plastic syringe via a rubber tube (**Fig. 2-8**). An electronic balance, which could read 0.01 g, was required for weighing the drops.

The same samples used in the capillarity experiment were examined.

<Procedure>

Ten drops of pure water were slowly dropped by syringe into a 50 mL Erlenmeyer flask, of known weight (see Fig. 3-8). Then, the mouth of the flask was closed by another rubber stopper to prevent any loss of sample through evaporation. The flask with the stopper was weighed again. Thus, the weight of ten drops of pure water could be calculated. The same procedure was carried out for all detergent samples.

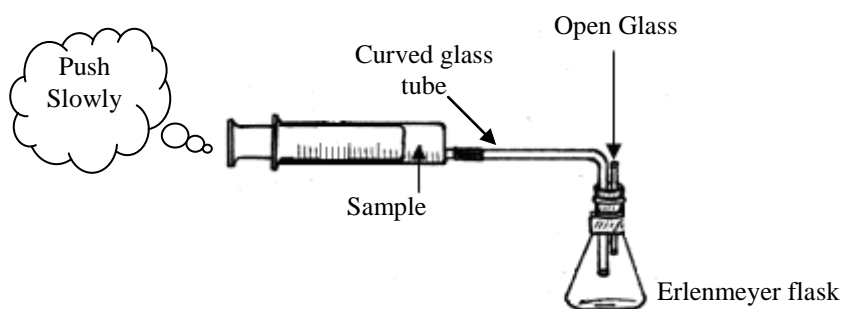

Fig. 3-8: Experimental setup for drop-weight

<Hazards>

No chemicals or procedures used by students cause any significant hazards in this experiment.

<Result and discussion>

The drop weights decreased rapidly as the detergent concentrations increased as shown in **Fig. 3-9**. It can be explained that the strong surface tension of water forms because of the attractive force between water molecules which acts like an invisible membrane on the surface (**Fig. 3-2**). As seen in **Fig. 3-5**, surface tension tends to hold the drop on the glass tube but it is opposed by gravity that tends to pull the drop downward. Therefore, the stronger the surface tension the heavier the drop will be. However, when detergent was introduced into the water there was an interaction between water molecules and detergent molecules. The attractive force between water molecules and detergent molecules was weaker than that between water molecules and water molecules. Hence, the tension on the surface was weakened in the presence of detergent. As a result, it could not maintain drop weights as heavy as in pure water. As shown in **Fig. 3-9**, the weight of water drops were decreased drastically when the concentration of detergent was increased. The results of drop-weight method showed very similar to that of capillary. The graph of the comparison of these two methods is shown in **Fig. 3-10** in which the curves almost overlapped each other.

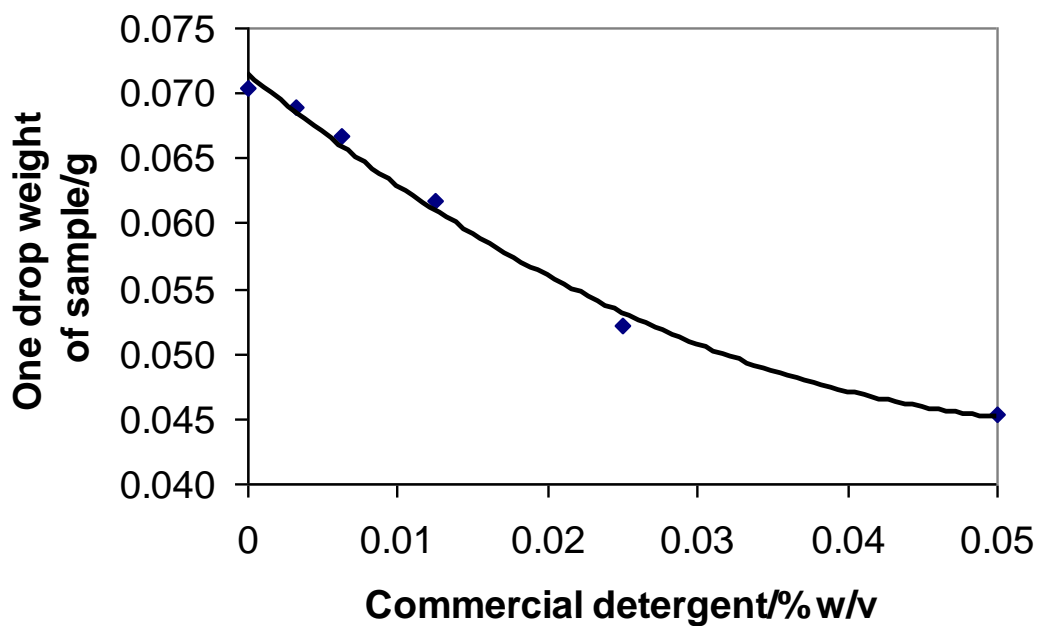

Fig. 3-9: The decrease in weight of a sample drop against detergent concentrations

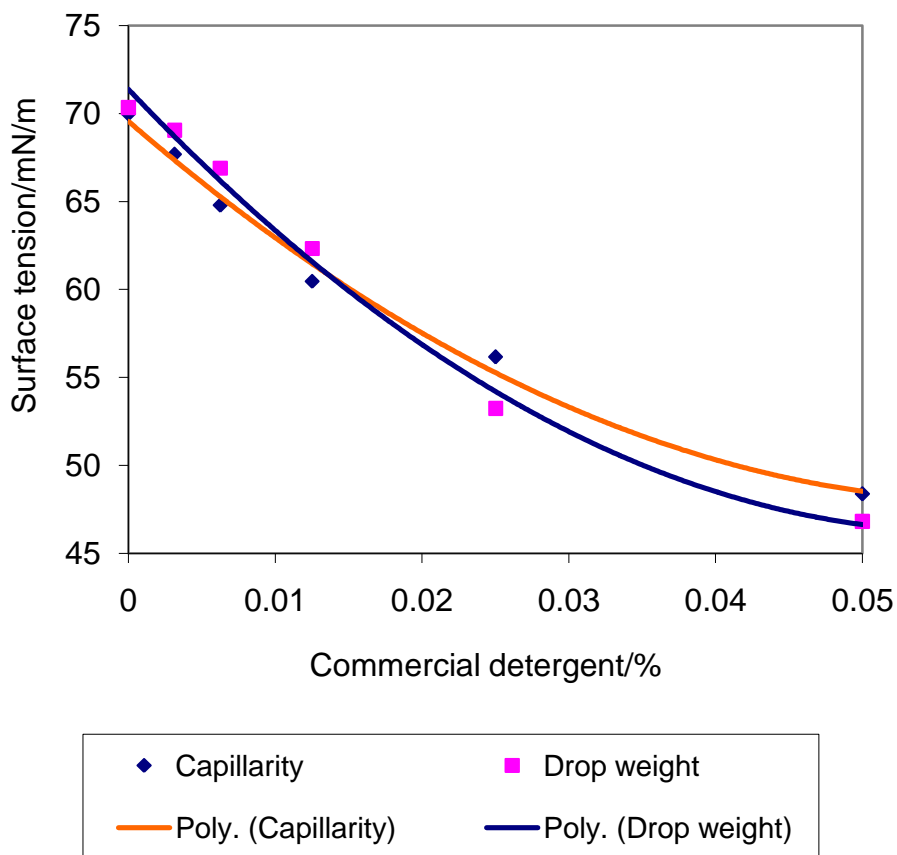

Fig. 3-10: Comparison of the two methods: capillarity and drop-weight

In our study, we also compared the effect on the surface tension of water of a commercial detergent with that of sodium dodecyl sulfate (SDS), a standard detergent usually used in the laboratory research. The results showed that the commercial detergent (KAO brand, product of Japan) produced a stronger decrease in surface tension of water than the SDS. As seen in the **Fig. 3-11**, the drop weight of sample containing the commercial detergent diminished drastically at the concentration of 100 ppm, whereas that of the sample containing the SDS decreased more gradually.

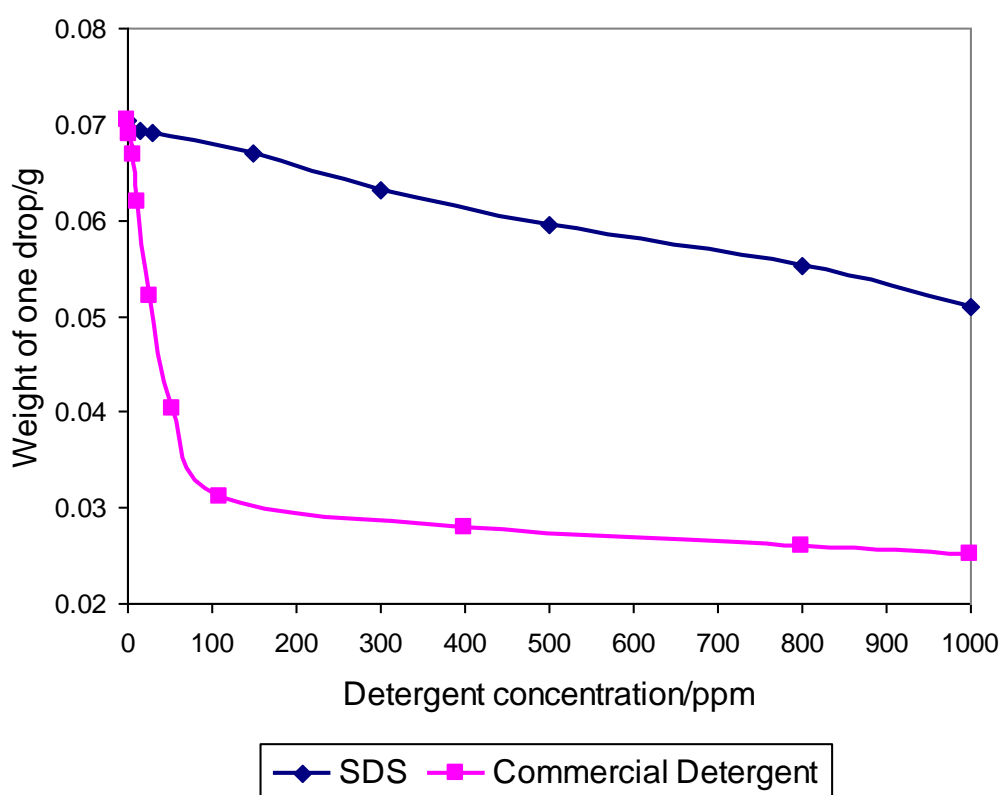

Fig. 3-11: Comparison of the effect on the surface tension of water between commercial detergent and sodium dodecyl sulfate (SDS).

This result can clearly indicate that the effect of commercial detergents on water surface tension can contribute to environmental consequences since they are used widely for washing and cleaning in homes, factories and industries if the waste water from these sources usually flows directly into natural watercourses such as lakes or rivers without treatment.

Detergent pollution can contribute to the poisoning of living things in water and also increase nutrient levels that can cause the Eutrophication phenomena in the body of water.

6. Determining the effect of detergent on surface tension by marbling ink

<Materials>

The materials necessary for this experiment are also simple, such as a water container, a dropper, pieces of paper (filter paper, or painting paper) cut in a circle shape to fit the water container, and marbling ink (painting oil) (**Fig. 3-12**).

Six samples of a commercial detergent (23% detergent, MITARA washing liquid, Product of Japan) were prepared in the concentrations of 5×10^{-4} %, 4×10^{-4} %, 3×10^{-4} %, 2×10^{-4} %, 1×10^{-4} % and 0.5×10^{-4} % respectively.

<Procedure>

At first, pure water was used. A container was about one third filled with pure water and then it was left to stand. A drop of marbling ink was dropped onto the middle of the water surface in the container. When the ink had spread to the maximum extent over the water surface, a piece of round paper was placed immediately over it. Then, the piece of paper with a print of the marbling ink on it was taken out and dried. Finally, the surface area of printed marbling ink on the paper was measured and calculated. It was necessary to measure the surface area by taking the average of the longest and shortest diameters found on the paper.

Each detergent sample was tested in the same way. However, it must be noted that the container used for each sample must be completely cleaned with pure water several times, so that there are no traces of soap or detergent.

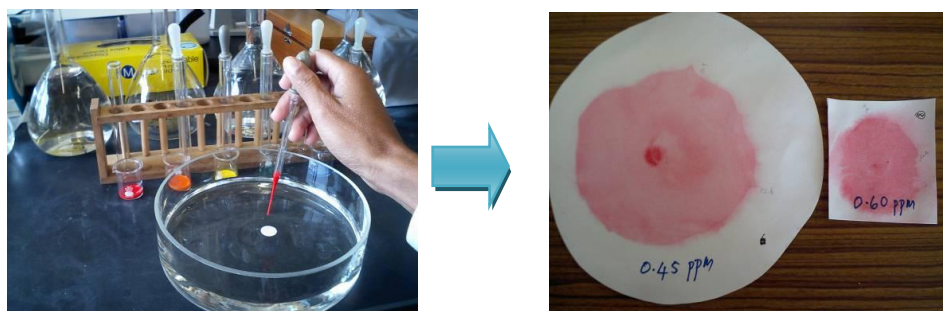

Fig. 3-12: Marbling ink and ink-printed papers

<Hazards>

No chemicals or procedures used by students cause any significant hazards in this experiment.

<Result and discussion>

The area of one drop of marbling ink spreading on the water surface became smaller with the increase of concentration of commercial detergent (**Fig. 2-13**). Marbling ink is a kind of surfactant that can also lower the surface tension of water but it is considered to be less effective than detergent. When a drop of marbling ink is added to the surface of water, the area which is occupied by the ink has lower surface tension than the area without ink. Because of the imbalance of these two tensile forces, the area without ink, which has stronger surface tension, pulls the ink outward from the center to spread on the water surface as far as possible. The stronger the surface tension, the stronger the pulling force and the larger the area of the marbling ink.

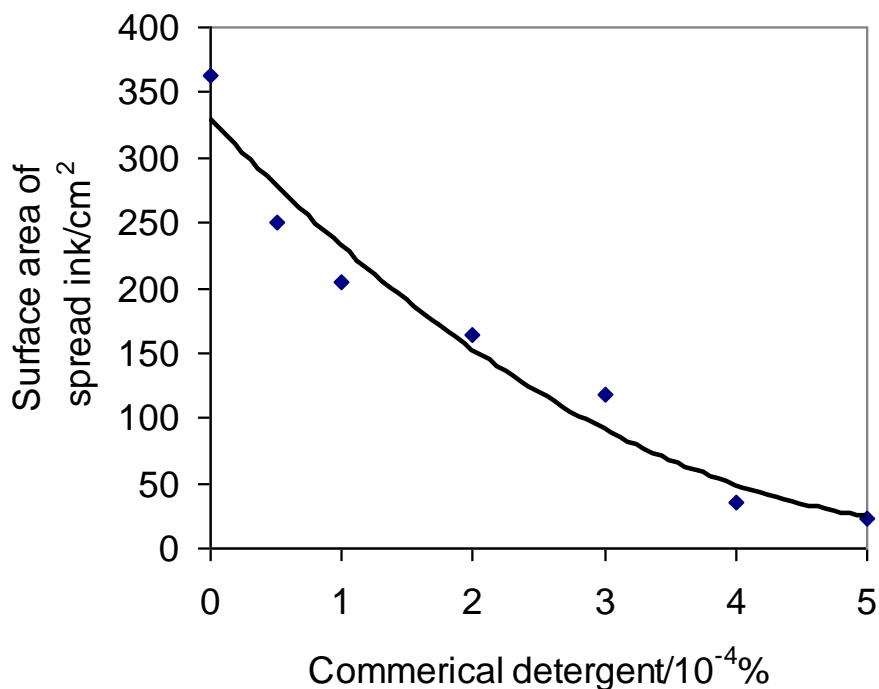

Fig. 3-13: The decrease in area of marbling ink against detergent concentration

Since detergent lowered the surface tension of the water, samples containing detergent produced smaller areas of marbling ink than in the case of pure water. The area decreased according to the increase of detergent concentration.

III. DETERGENT ANALYSIS BY FABRIC DYEING

1. Background

Several analytical methods using dyes to extract detergent compounds from samples have been used in determining the quantity of detergent in water. The most common analytical method in Japan uses methylene blue (MB, a cationic dye) which associates with anionic detergents to produce a neutral compound that is extracted into chloroform (JIS, 1991; Long well, 1955), according to the Japanese Industrial Standard (JIS MB method). Similar methods have also been published in the Journal of Chemical Education in which copper-ethylenediamine is used instead of methylene blue (Rechard John, 1999; P. T. Crisp,

1983). PONAL KIT ABS method is another technique using the purple-dye cobalt (III) complex cation to produce a neutral compound with anionic detergents and benzene as the extraction solvent (Dojindo). However, the above methods all require organic solvents which are harmful and modern lab equipment for analysis such as an atomic absorption spectrometer, anodic stripping voltammeter and spectrophotometer that are troublesome for high school students to handle.

Since the use of harmful organic solvents in classrooms has become a critical issue of concern in the field of chemistry education, one aim of this study was to seek a safer method. The method here used fabrics instead of organic solvents as media to extract the neutral compounds made between the dye and detergent from the solution. A calibration curve was obtained by dyeing pieces of fabric in dye solutions of several different detergent concentrations. A hand-made reflection photometer, which could be assembled from inexpensive materials, was used to determine the color depth of dyed fabric.

2. Experiment

<Materials>

Assemble of a hand-made Reflection photometer: The body was an L-shaped PVC tube usually used for tap water. The light source was a light emitting diode (LED) placed in a hole in a PVC cap connected to two 1.5 V dry cells. Light reflected from the dyed fabric was detected by a Cadmium Sulfide (CdS) device attached to another PVC cap, which showed low resistance in the light and high resistance in the dark. The CdS resistance value was measured by a multimeter (**Fig. 3-14 & 3-15**).

Several types of white fabrics (see Table 3-3) collected from the home economics laboratory were cut into pieces of ca. 4 cm x 4 cm. A pair of tweezers was used for picking up the fabric pieces from the dye solution. Several 100 mL beakers were used as dyeing containers (any plastic cups also can be used instead of beakers).

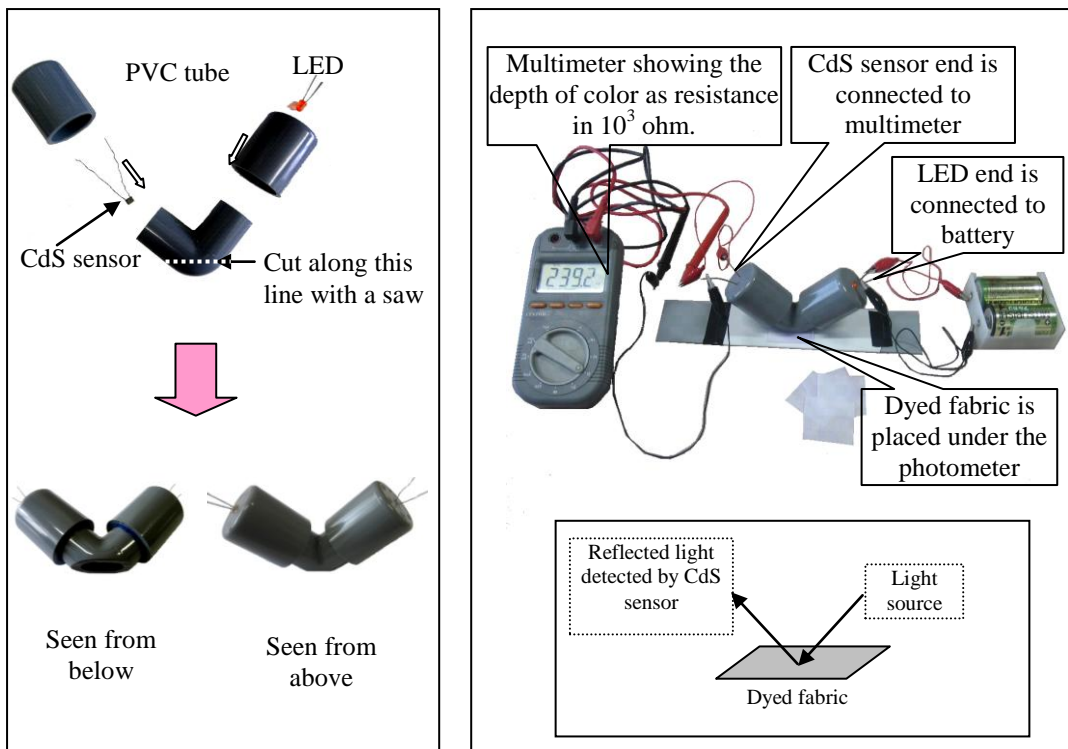

(a) (b)
Fig. 3-14: (a) Assemble of the hand-made reflection photometer; (b) measuring color depth of dyed fabric

Various different concentrations from 0 to 12 ppm of detergent solution [sodium dodecyl sulfate (SDS)] were prepared. Then several kinds of dye solutions, including anionic dyes and cationic dyes as seen in **Table 3-4**, were investigated in this research.

Table 3-3: Types of fabrics and their polymer structures used in the study

(Menachem Lewin, 1983 & 19984; Lauren J, 1999)

Fabric type	Polymer Structure
acrylic (Cashimilon): Cashimilon contains a few co-polymers	$* \left[\text{CH}_2 - \text{CH}(\text{CN}) \right]_n *$
Polyester (PET)	$* \left[\text{O} - \text{C}_6\text{H}_4 - \text{C}(=\text{O}) - \text{O} - \text{CH}_2 - \text{CH}_2 - \text{O} \right]_n *$

Acetate	
65% Polyester and 35% Cotton	
Nylon 6,6	
Viscose Rayon	
Cuprammonium Rayon	$[CuC_6H_8O_5]_n$
Silk	
Wool	
Cotton	

Table 3-4: Types of anionic and cationic dyes used in the research

(Aldrich, (2003-2004); Panreac website)

Name of dye	Color	Color index number	Molecular structure and ionic type
Methyl Violet	Violet/purple	<i>Extra pure</i>	

Methylene Blue	Blue	52015	
Cobalt (III) complex tablet	Violet/purple	-	
Rhodamine B	Red	45170	
Brilliant Blue FCF	Blue	42090	
Acid fuchsine	Red	42685	
New cocchine	Brown	16255	
Cal Red (Calcocarboxylic Acid)	Violet	-	
Indigo Carmine	Blue	730	

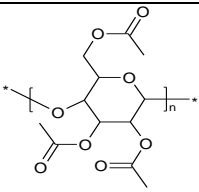
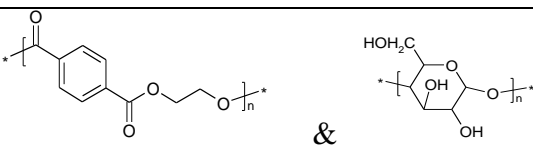
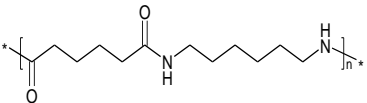
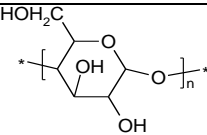
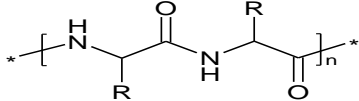
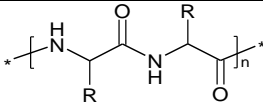
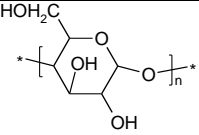
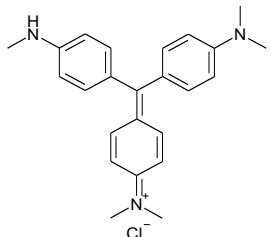
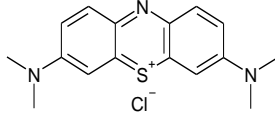
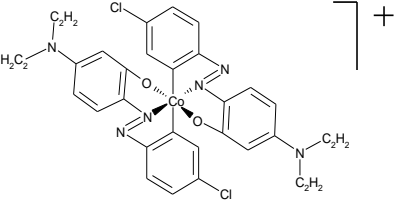
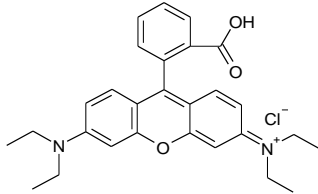
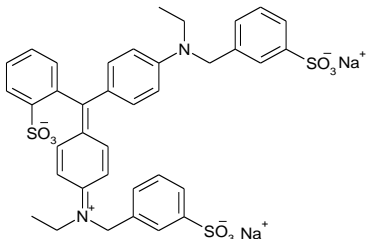
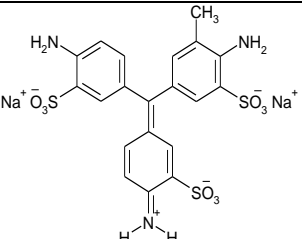
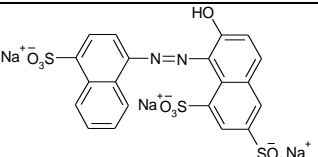
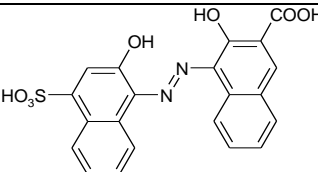
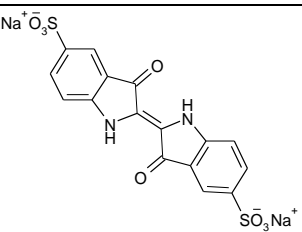
<Procedure>

Ten milliliters of pure water (blank) and each SDS solution were put into separate 100-mL beakers. Then 2 mL of dye solution was added and stirred well. Pieces of fabric were dipped into each resulting solution for 15 minutes maintained at 25°C in a water bath. The pieces of dyed fabric were picked out from the solutions and air dried with an electric dryer. Finally, the color depth of each dried fabric was measured as the resistance value on the multimeter in 10^3 ohm ($k\Omega$) by using the hand-made reflection photometer, as shown in **Fig. 3-14b**. It was necessary to use an LED light source which was the complimentary color to the color of the dyed fabric in the measurement of color depth (**Table.3-5**). For instance, according to the color wheel above, the yellow LED was used to measure the color depth of the purple dyed fabric, and the orange LED was used for the blue dyed fabric, etc.

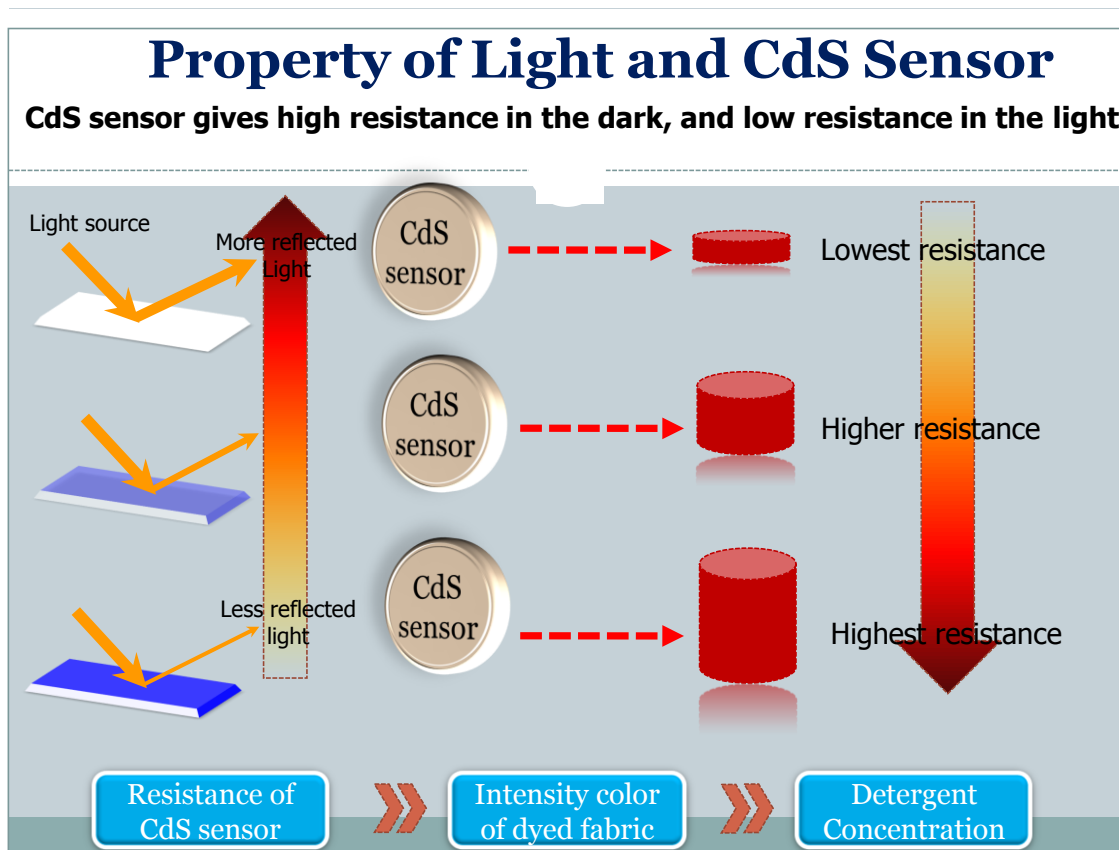

Fig. 3-15: The relationship of CdS sensor property with the light

Table 3-5: Approximate wavelength of color and its complementary color

(Complementary color, 2006)

Main Color	Wavelength (nm)	Complementary Color
Purple	380-435	Yellow
Blue	435-480	Orange
Blue-Green	480-500	Red-Orange
Green	500-560	Red
Yellow-Green	560-580	Red-Purple
Yellow	580-595	Purple
Orange	595-605	Blue
Red	605-750	Green
Red-Purple	750-780	Yellow-Green

Note: *Main Color + Complementary Color = White color*

<Hazards>

No chemicals or procedures used by students cause any significant hazards in this experiment.

2. Result and discussion**Table 3-6 The combination of fabrics and dyes used in the research**

Dye \ Fabric	D1	D2	D3	D4	D5	D6	D7	D8	D9
Acrylic (Cashimilon)	○	×	○	○	○	×	×	×	×
Polyester	×	×	×	×	×	×	×	×	×
Acetate	×	○	×	×	×	×	×	×	×
65% Polyester & 35% Cotton	○	×	×	×	×	×	×	×	×
Nylon 6,6	×	×	×	×	×	×	×	×	×
Viscose Rayon	×	×	×	×	×	×	×	×	×

Cuprammonium Rayon	×	×	×	×	×	×	×	×	×
Silk	×	×	×	×	×	×	×	×	×
Wool	×	×	×	×	×	×	×	×	×
Cotton	×	×	×	×	×	×	×	×	×

Note: (○) means the color depth of dyed fabric affected by detergent, and (×) means there was no effect.
D1: Methyl Violet, D2: Methylene Blue, D3: Cobalt Complex, D4: Rhodamine B, D5: Brilliant Blue,
D6: Acid Fuchsine, D7: New Coccin, D8: Cal Red, D9: Indigo Carmine

Table 3-6 shows the test results of combinations of the ten kinds of fabrics and nine kinds of dyes. Only six combinations of the three kinds of fabrics and five kinds of dyes showed clear relationships between color depth and detergent concentration. There were a few different patterns of results which will be described according to the type of the dyes involved; cationic or anionic.

<Dyeing in cationic dye>

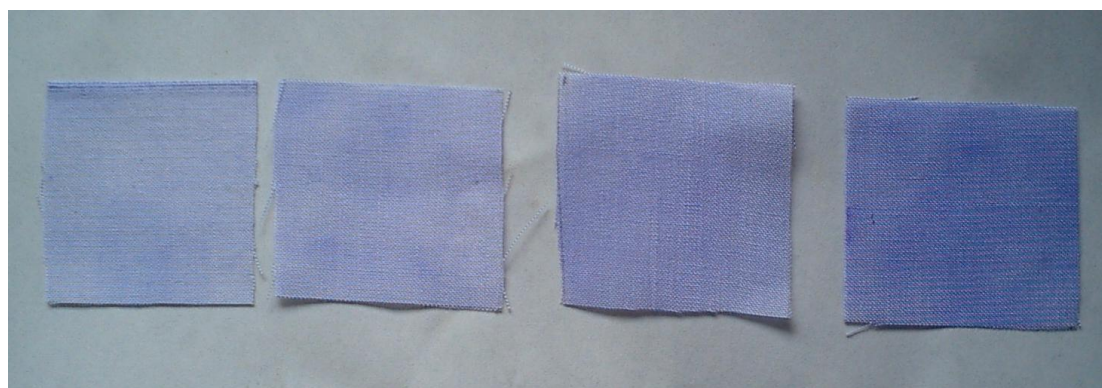

Fig. 3-16: The increase of color intensity when Cashimelon acrylic fabric dyed in methyl violet solution in the increase of detergent concentration

Color depth of the dyed fabric increased with the increase of detergent concentration in acrylic fabric dyed with methyl violet, rhodamine B, and cobalt (III) complex, and in acetate fabric with methylene blue. **Fig. 3-16** is an example of dyeing acrylic fabric in methyl violet. In this case, acrylic and acetate fabrics acted like an organic solvent such as

chloroform or benzene to extract the neutral compound formed by the anionic detergent and cationic dye as seen in the illustration of **Fig. 3-17**. Increasing detergent concentration produced an increase in the amount of neutral compound which was adsorbed onto the fabric.

The color depth on the dyed fabric corresponded to the concentration of detergent.

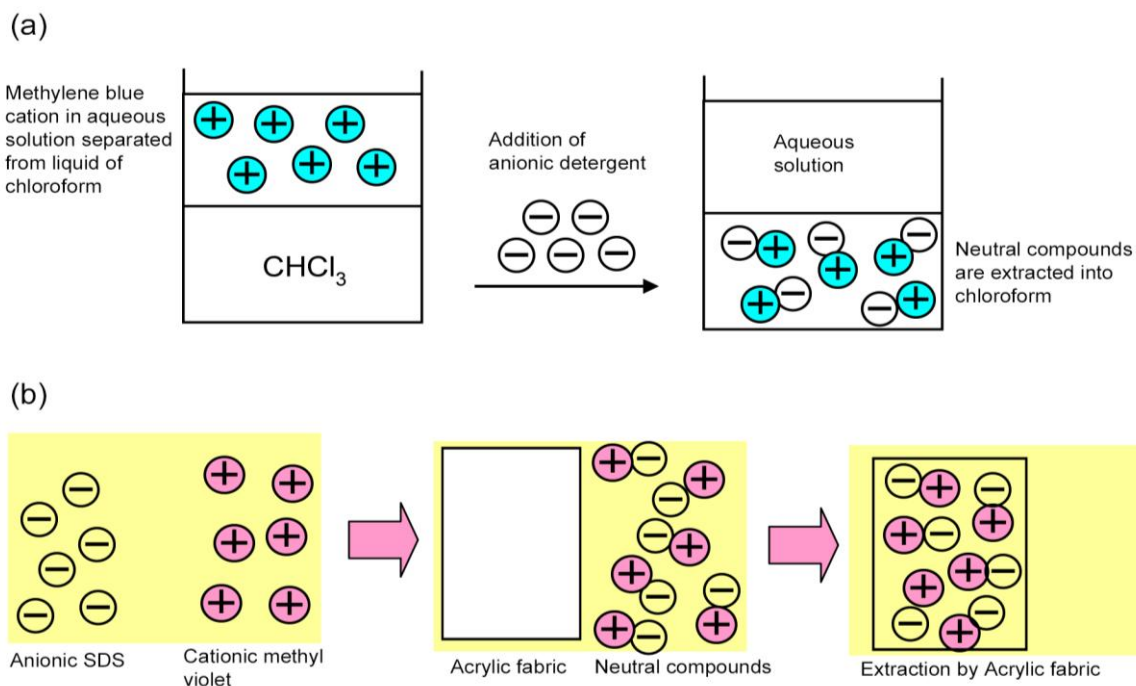

Fig. 3-17: The association between cationic dye and anionic detergent, (a) JIS MB method and (b) fabric dyeing

As the results, the graphs in **Fig. 3-18** showed the linear relationship between the resistance of the CdS device and detergent concentrations. These graphs could be used as calibration curves for the determination of detergent concentration.

The color depth decreased against increasing detergent concentration when 65% Polyester and 35% Cotton fabric was dyed with cationic methyl violet (See Fig. 3-18). In this case, the fabric decreased in ability to adsorb neutral compounds. Instead, it adsorbed more cationic dye than neutral compounds. In the solution, the neutral compounds produced from the combination of cationic methyl violet and anionic detergent increased when the concentration of detergent increased, but the color depth on the fabric decreased. This means

the 65% Polyester and 35% Cotton fabric could not act as an organic solvent as the case of acrylic and acetate fabrics.

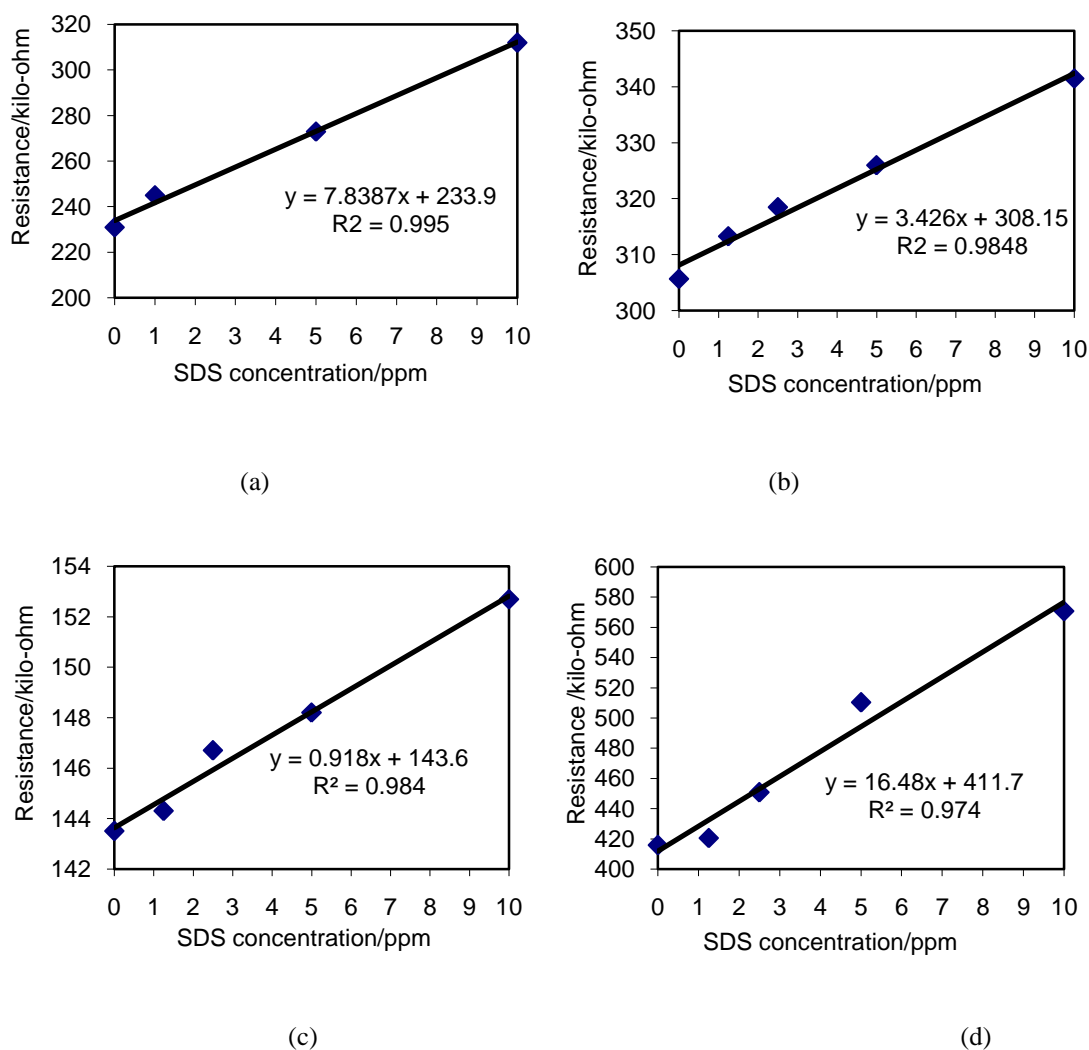

Fig. 3-18: Calibration curves of CdS resistance against SDS concentration (a) Acrylic fabric dyed in 0.005%w/v methyl violet measured with yellow LED. (b) Acrylic fabric dyed in 0.01%w/v Rhodamine B measured with green LED. (c) Acrylic fabric dyed in 1.5%w/v cobalt (III) complex measured with yellow LED; and (d) Acetate fabric dyed in 0.01%w/v methylene blue measured with orange LED.

<Dyeing in anionic dye>

This investigation showed that increasing the concentration of detergent in the solution could also decrease the color depth on the dyed fabric. As shown in **Fig. 3-19**, the color depths decreased against the increase in concentration of detergent when acrylic fabric was dyed in an anionic dye, brilliant blue. As the results, the resistant decreased drastically

(Fig.3-20) and similar result is shown in Fig. 3-21 for the dyeing of polyester and 35% cotton fabric in 0.001%w/v methyl violet. This result indicated that acrylic fabric prevented the adsorption of anionic dye by anionic detergent due to electronic repulsion.

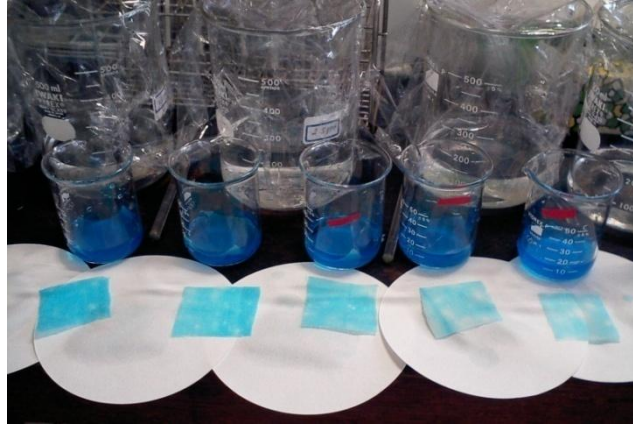

Fig. 3-19: The decrease of color intensity when Cashimelon Acrylic fabric dyed in Brilliant Blue in the increase of detergent concentration

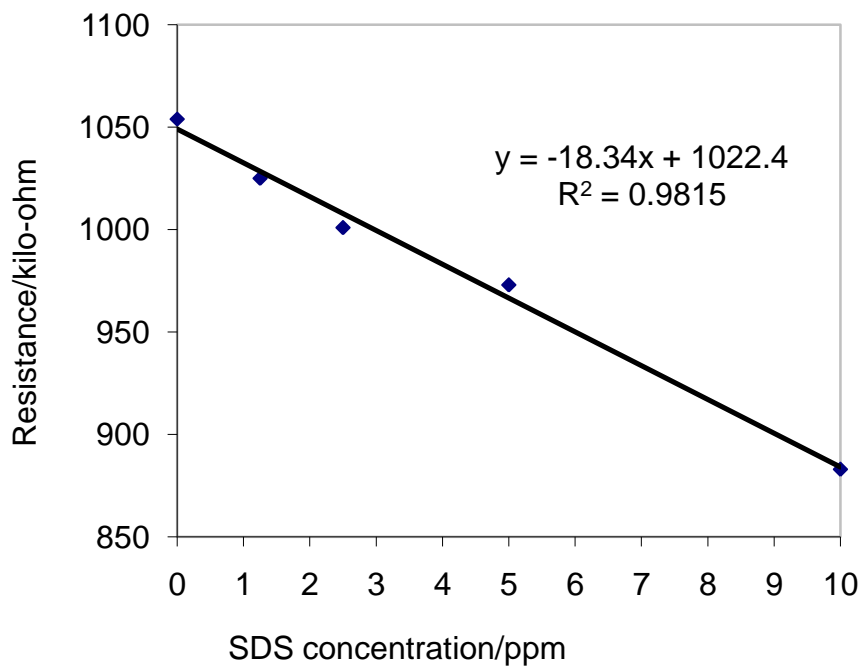

Fig. 3-20: Calibration curve of CdS resistance against SDS concentration when acrylic fabric was dyed in 0.02%w/v brilliant blue for 5 min. The resistances were measured with an orange LED

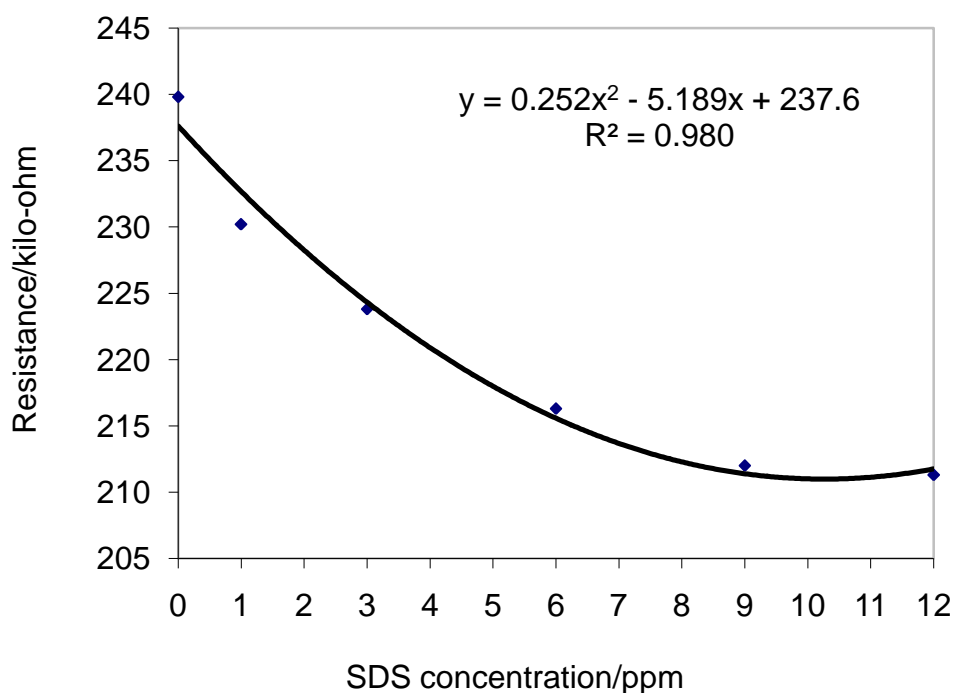

Fig. 3-21: Calibration curve of CdS resistance against SDS concentration when 65% polyester and 35% cotton fabric was dyed in 0.001%w/v methyl violet. The resistances were measured with a yellow LED.

Further observation clearly proved that anionic detergent could prevent anionic brilliant blue from adsorbing onto fabric. In **Fig. 3-22**, the color depth did not change much at the high concentrations of detergent (**site A**), although the dipping time was increased. In contrast, when the dipping time was extended the color depth increased drastically (**Area B**). This means that acrylic fabric can adsorb brilliant blue dye more easily at the lower concentration of detergent, but not at the higher concentration.

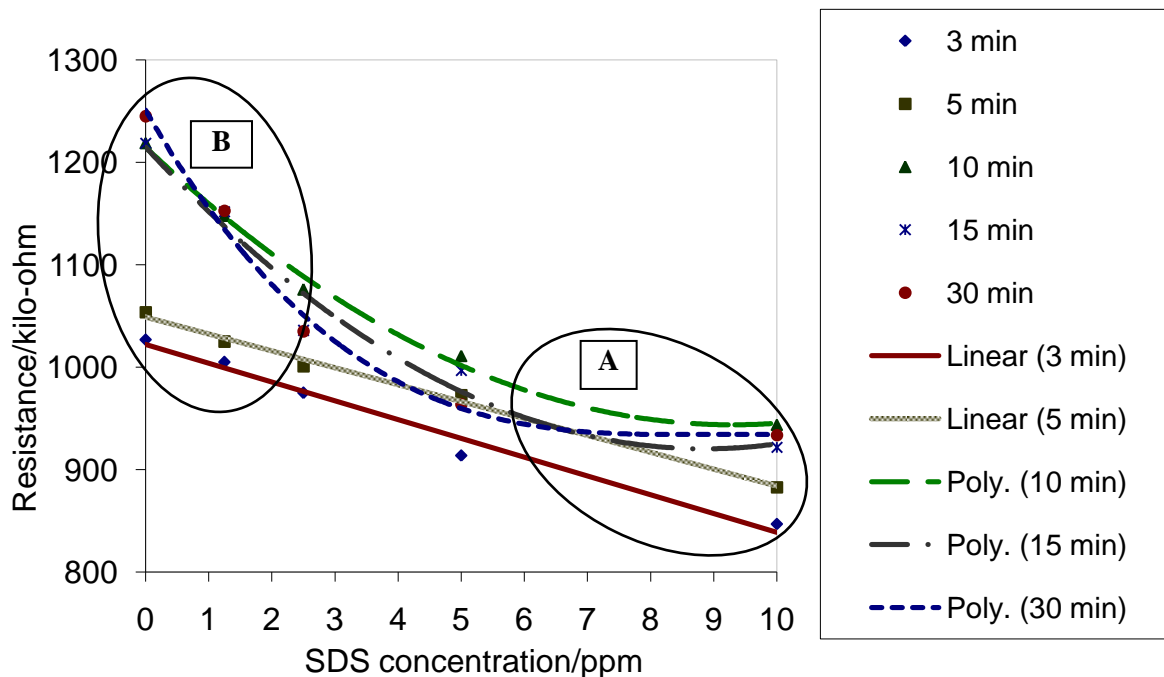

Fig. 3-22: Curves of CdS resistance against SDS concentration when Acrylic fabric was dyed in anionic brilliant blue for different length of times.

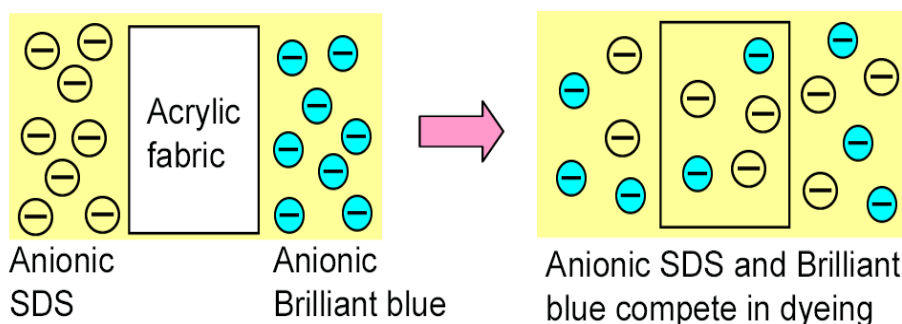

Fig. 3-23: Chemical interaction when acrylic fabric dyed in anion dye

In this case, the interaction between acrylic fabric and anionic detergent is considered to be stronger than the interaction between acrylic fabric and anionic brilliant blue. Also the repulsion force between anions of detergent and brilliant blue can prevent acrylic fabric from being dyed by anionic brilliant blue (**Fig. 3-23**).

IV. APPLICATION IN CLASSROOM

1. Lesson Instruction

As mentioned in the limitations of the study, the selected practical activities were introduced into the actual classrooms in order to determine their effectiveness as science classroom activities. Here, the selected practical activities included the observation of the properties of soap and detergent, the effect of detergent on water surface tension by capillarity and drop weight methods, and the analysis of detergent in water by fabric dyeing method. In the case of detergent analysis in water, a common method using PONAL KIT ABS was also introduced to students so that the students could compare the results with the fabric dyeing method that we developed. This study was carried out with 34 Japanese students and 30 Cambodian students in High School, grade 12.

Before the experimental procedures were explained, students were given some background information of each lesson, such as surface tension, soap or detergent, methyl violet dye, brilliant blue, etc. in order to give them images of the chemical interactions that would occur during the fabric dyeing. The chemical structures of detergent and dyes showed the types of ionic charges on each component, that is, detergent has negative charge, methyl violet dye has positive charge, and brilliant blue dye has negative charge on their ionic structures. The students were then able to give their predictions on what would happen when detergent is mixed with each dye.

2. Evaluation of teaching and learning materials

The lessons and the developed teaching and learning materials were evaluated based on the students' performance on pre/post tests and their responses on the questionnaires. The evaluation focused on three aspects of the prepared activities: (1) knowledge improvement, (2) feasibility in classroom settings, and (3) students' satisfaction.

<Knowledge improvement>

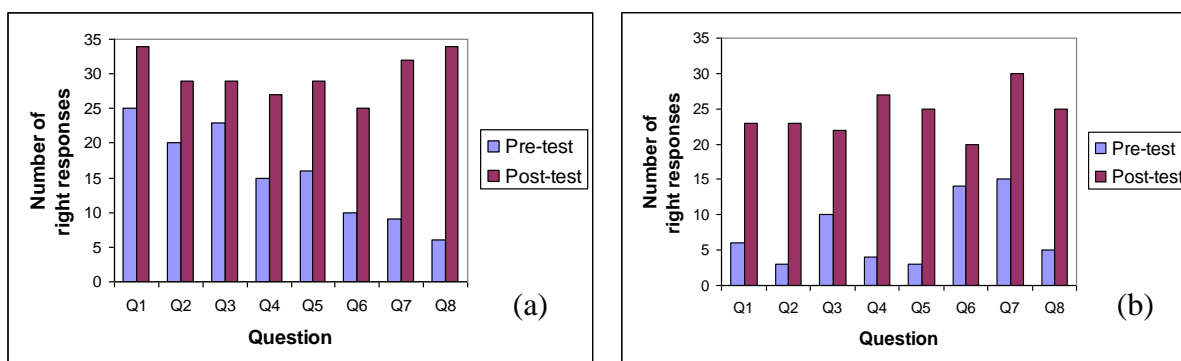

Fig. 2-24: Students' performance on Pre-test and post-test: (a) Japanese students, (b) Cambodian students

Note:

Q1: What are the raw materials to produce soap?	Q5: What's hydrophilic?
Q2: Which is a soap molecule?	Q6: How does soap or detergent remove dirt?
Q3: Which is a detergent molecule?	Q7: What's surface tension of water?
Q4: What's hydrophobic?	Q8: How does detergent affect on water surface tension

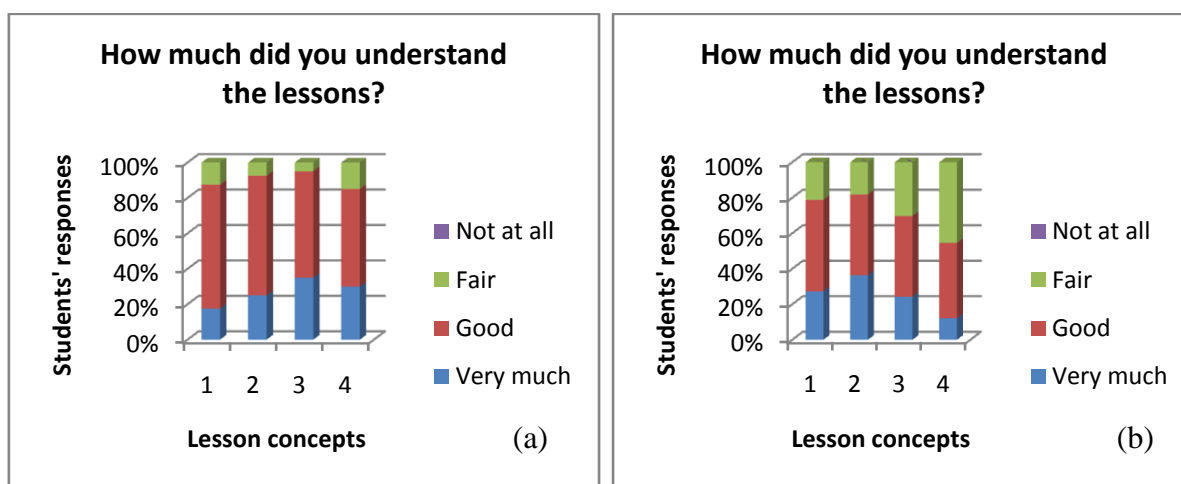

Fig. 3-25: Students evaluated their understanding of the lessons: (a) Japanese students, (b) Cambodian students

Note:

Concept 1: Soap and detergent molecules	3: Effect of detergent on water surface tension
Concept 2: Surface tension of water	4: Determination of detergent concentration in water

In general, students' knowledge about detergent concepts appeared to have improved through the Activities after the lessons. As seen in **Fig. 2-24**, students received higher scores in the post-test. These results appeared in accord with students' responses on the

questionnaires to evaluate their understanding of each concept (Fig. 3-25). Many of them said that they understood the concepts taught in the lessons “good” and “very well” and only few said “fair”. Comparing the two countries, Japanese students showed better performance in terms of both pre-knowledge and the ability to learn the new concepts introduced in the lessons.

<Applicability>

The students could use the developed materials and participate in all of the activities designed in the lessons without difficulty. Responded to the question “Are the experiments easy for you to conduct?”, most of Japanese answered “Easy” and most of Cambodian students answered “easy” and “Fair”. However, no one of the students in both countries said “difficult” (Fig. 3-26). This shows that the apparatus used in the experiments and the lesson activities could be applicable and feasible for students in Japanese secondary classroom settings, as well as in Cambodia.

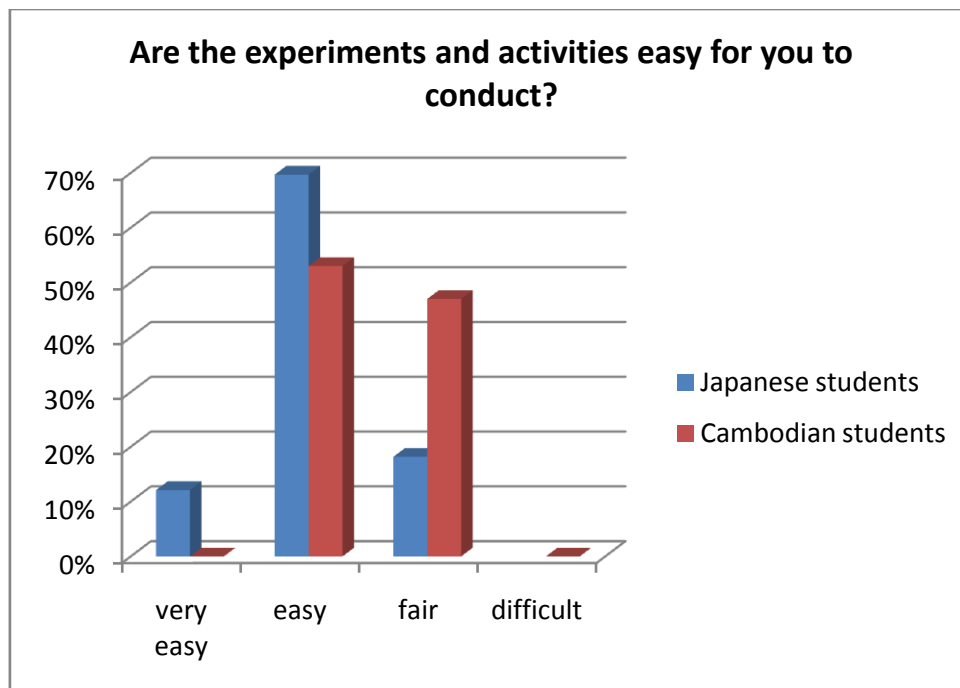

Fig. 3-26: The extent of difficulty of the activities in the lessons

<Students' satisfaction>

Both Japanese and Cambodian students gave high satisfaction to all concepts introduced in the lessons (Fig. 3-27). At the same time, they appeared to enjoy all of the activities introduced in the lessons (Fig.: 3-28). Most of them said similarly that they were impressed and enjoyed the activities very much. In case of Cambodian students, they suggested having such experimental activities in science classrooms more often, so that they can have more opportunities to do scientific observation and link theory to reality.

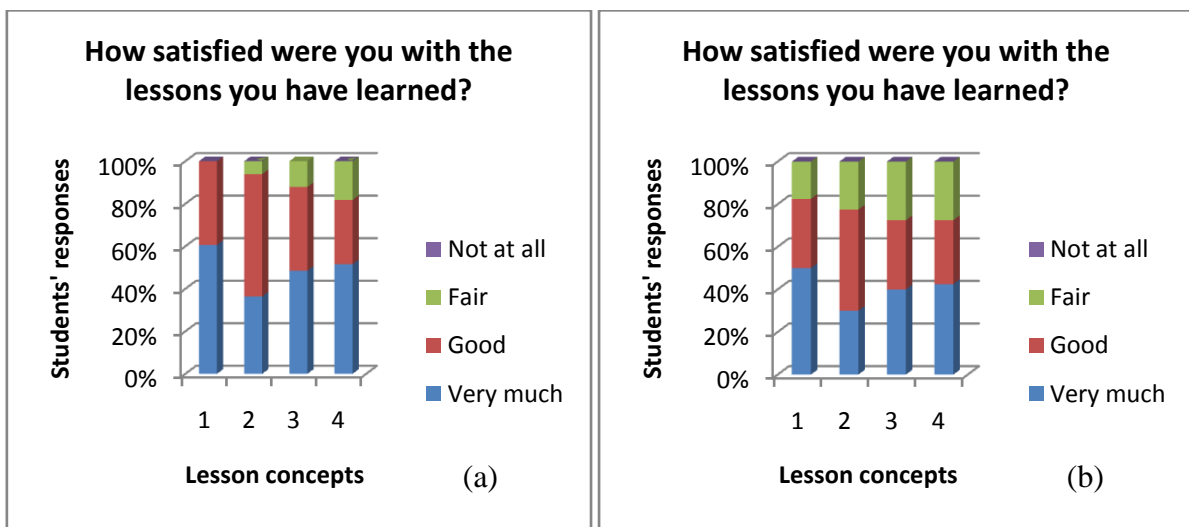

Fig. 3-27: Students' satisfaction: (a) Japanese students, (b) Cambodian students

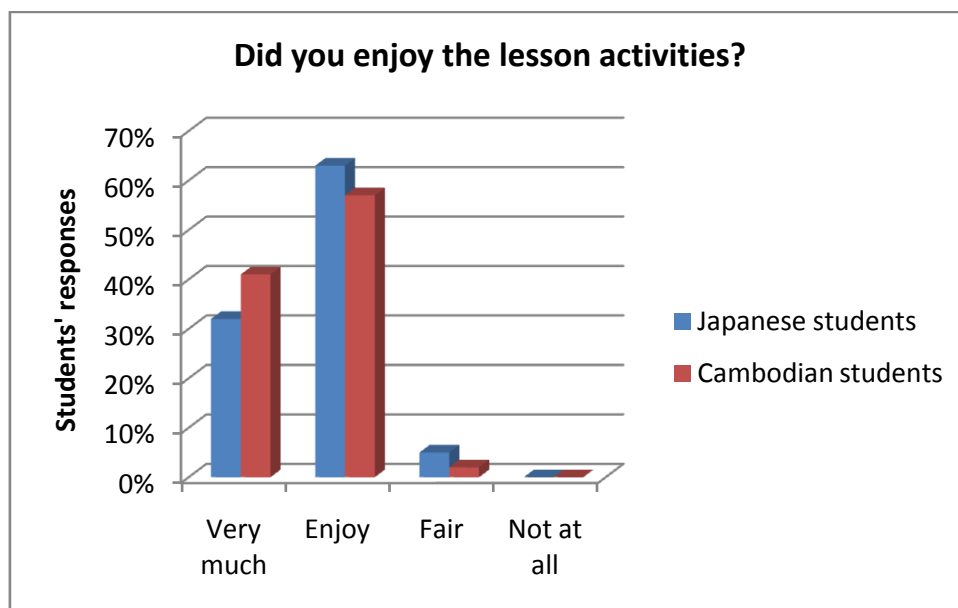

Fig. 3-28: Extent of students' enjoyment in the lesson activities

V. CONCLUSION

In conclusion, the introduced lessons and the learning materials in the actual classrooms could contribute the students with experience to the actual scientific phenomena linking to the scientific theory. The developed teaching and learning materials for detergent as described in this chapter could help the students learn actively in the chemistry classroom, where they showed much enjoyment during the lessons. Their knowledge and skills were improved significantly throughout the lessons, namely they could: (1) give the differences between soap and detergent in terms of their molecular components and chemical properties, (2) interpret the effect of soap or detergent as a kind of surfactants which effectively decreases the surface tension of water, and (3) experience and apply some methods to determine the amount of detergent and soap in environmental water.

Based on the students' performance through the pre/post tests and their feedbacks on the questionnaires, it can indicate clearly that all the activities and learning materials developed in this research could be appropriately applied in the chemistry secondary classroom to enhance students' understanding the concepts relevant to detergent.

REFERENCES

- Aldrich, (2003-2004), handbook (catalogue) of fine chemicals and laboratory equipment,
Japan
- Atkins Peter, Paula de Julio, (2002), ATKINS' Physical Chemistry, 7th Edition, OXFORD,
150-154
- Barrow M. Gordon, (1973), Physical Chemistry, 3rd Edition, 526-531
- Complementary color: <http://www.webdesignref.com/chapters/13/ch13-01.htm>, access on
10th July, 2006
- Dojindo Chemistry Research Institute Co., Ltd., PONAL KIT-ABS, Operation manual for the
simplified method for the measurement of anion surface-active agent.
- Dominguez Ana, Fernandez Aurora, Gonzalez Noemi, Iglesias Emilia & Montenegro Luis,
(1997), *Journal of Chemical Education*, 74, 1227-1231
- Ewart H. Alan, Hyde E. Kenneth, (1992), *Journal of chemical Education*, 69, 814-815
- Furton G. Kenneth, Norelus Arold, (1993), *Journal of Chemical Education*, 70, 254-257
- Gani Nasimul, Khanam Jasmina, Franed Joe, Konzelman Jim, (2002), *Journal of Chemical
Education*, 79, 332-333
- Hideaki, Chihara ed, (1975), Butsuri Kagaku Jikkenho (Experiment on Physical Chemistry).
In *Surface tension of water*; Tokyokagaku dojin, 195-202
- Jasien G. Paul, Barneth Glenn, Speckhard David, (1993), *Journal of Chemical Education*, 70,
251-252
- JIS (*Japanese Industrial Standard*) K0101, (1991), p. 68
- John Richard, Lord Daniel, (1999), *Journal of Chemical Education*, 76, 1256-1258.
- Lewin Menachem, Sello B. Stephen, (1983), *Chemical Processing of Fibers and Fabrics:*
Functional Finishes part B, New York: M.Dekker

- Lewin Menachem, Sello B. Stephen, (1984), *Chemical Processing of Fibers and Fabrics: Fundamentals and Preparation Part B*, New York: M.Dekker
- Manicie J. Longwell, (1955), *W.D. Analyst*, 80, p. 167
- Meyer E. F., Wyshel G. M, (1986), *Journal of Chemical Education*, 63, 996–997
- Moor J. Walter, (1972), *Physical Chemistry*, 4th Edition, 847-489
- P. T. Crisp, J. M. Eckert, N. A. Gibson, (1983), *Journal of Chemical Education*, 60, 236-238.
- Panreac: molecular structure of chemical dyes online catalogue. <http://www.panreac.com>,
accessed on 2nd February, 2006
- Pickard J. Lauren, Harris E. Mary, (1999), *Journal of Chemical Education*, 76, 1512-1513
- Schulz C. Pablo, Clausse Daniele, (2003), *Journal of Chemical Education*, 80, 1053-1056
- Worley D. John, (1992), *Journal of Chemical Education*, 69, 678-680

Chapter IV

DEVELOPMENT OF HAND-MADE CONDUCTIVITY METER AND ITS APPLICATION TO FRUIT AND VIGETABBLE SOLUTION

I. INTRODUCTION

The commercial electrical conductivity (EC) instrument (e.g., Shimadzu portable Kohlraush bridge BF-62A) is user-friendly and ready-to-use, but it is expensive. It costs more than \$1000, however has not been available so far. A less expensive alternative EC meter uses electrodes to directly measure sample conductivities with the conductivity value being shown on a screen without calculation. For instance, HORIBA LAQUA EC meter B-771 which costs \$240. Other methods include a handmade instrument equipped with a light bulb or a light-emitting diode (Rosso, 1986; Gaded, 1987; Vitz, 1987; Gadek, 1987). These measure the conductivity of different electrolyte solutions by noting the dimness or brightness of the diode. Students can use such devices easily, but the results are only qualitative and cannot compare electrolyte concentrations or the extent of dissociation in solution. Some electrical conductivity apparatus are only suitable for demonstration because they use a high-voltage, 120 V AC source (Rettich, 1989; Mercer, 1991). Others can only detect the presence of electrolyte in a solution through noting the electrical current (Hans, 1955; Colton, 1976; John, 1991). Susan K. S. Zawacky has also produced an inexpensive, semi-quantitative handmade conductivity tester (Susan, 1995), which could detect the conductivity of aqueous electrolyte solutions at different concentrations. However, assembly of the apparatus was complicated and it could not determine the actual conductivities of solutions. In this study, we developed a less expensive handmade conductivity meter that is easy to make and can be used in a high school chemistry classroom effectively and quantitatively.

The development of an easy to make, handmade conductivity meter based on Kohlrausch bridge principle is described. It was applied to measurements of 1) standard alkali halide solutions, 2) solutions derived from solutions isolated from ground up vegetables and fruits and 3) a reconstituted sports drink. Analysis using the conductivity data was used to

determine amounts of total electrolyte in some vegetables, fruits and the sports drink. Independent measures of the total amount of alkali were made by HCl titration of the combustions residue of these vegetables and fruits and compared with the conductivity values obtained by this apparatus. The paper also shows the significant potential for use and the effectiveness of the apparatus in the classroom through lessons introduced to high school students in both Japan and Cambodia

II. ELECTRICAL CONDUCTIVITY

1. Electricity and Ohm's Law

Flow of electricity through a conductor involves a transfer of electrons from a lower to a higher electric potential. An electric field applied to a material that has free charged particles causes these particles to flow through the material and around the circuit. How do we define and measure the electric current that passes through a material? And how do we measure the resistance of a material?

One of the basic principles of electricity is Ohm's law. Ohm's law describes the relationship between electric current, resistance and the applied potential difference. The strength of an electric current flowing through a conductor, i.e. the quantity of electricity flowing per second, is determined by the difference in potential applied across the conductor and by the resistance of the conductor to the current. According to Ohm's law the relation among these three quantities is given by

$$I = \frac{E}{R} \quad (1)$$

where I is the strength of current in amperes (A) flowing through a resistance R in ohms (Ω) under an applied potential E in Volts (V). This equation shows that the current strength is directly proportional to the difference in potential and inversely proportional to the resistance. In electric conductors, such as solid and molten metal and certain molten salts such as cupric

sulfide, cadmium sulfide, electrical conduction takes place by direct migration of electrons through the conductor under the influence of an applied potential.

2. Conductance and Conductivity

Electrical conductivity is directly related to electrical resistance. To understand electrical resistance, it supposes that a movement of electricity is like a man walking along a road and the substance through which electricity flows (usually electric wire) as the road. The road can be different, such as paved, gravel or muddy. Furthermore, if it is narrow it hinders the man's passage, causing him to expend much more energy on a long trip. The difficulty of passage on a bad road may be represented by the following expression:

$$\text{Difficulty of passage} = \frac{\text{kind of road} \times \text{length of road}}{\text{width of road}} \quad (2)$$

This expression can be directly converted to a formula for electric resistance:

$$\text{Resistance}(R) = \frac{\text{Resistivity}(\rho) \times \text{length}(L)}{\text{Area}(S)} \quad (3)$$

with the unit R in Ohms (Ω), L in centimeter (cm), S in square centimeters (cm^2) and ρ in Ohm centimeters ($\Omega \text{ cm}$).

Through eq (3), we can deduce that the greater the length and the smaller the cross-sectional area, the greater the resistance. And also we can understand that the greater the resistivity with the same length and the same area, the greater the resistance value. Each substance has its own resistivity value.

The resistance of an electrolytic conductor to the passage of current can be determined by the application of Ohm's law to such a conductor. However, instead of resistance, it is common to speak of the **conductance** G , which is merely the **reciprocal** of

the electrical resistance, so:

$$G = \frac{1}{R} \quad (4)$$

The units of conductance are expressed in reciprocal Ohms (Ω) called mhos (Ω^{-1}). By international agreement, mho (Ω^{-1}) is now called Siemens (S), that $1\text{S} = 1\Omega^{-1}$. The conductance of any conductor is proportional directly to the surface area of electrodes A and inversely to the distance between the electrodes L , namely,

$$G = \kappa \frac{A}{L} \quad (5)$$

where κ is specific conductance or **conductivity**. From the Equations 4 and 5, the

conductivity κ can be derived as : $\kappa = \frac{L}{A} \times \frac{1}{R}$ (6), (P. Atkins, 2006)

here the unit of conductivity is Siemens per centimeter (S cm^{-1}). Because in this study the focus was on electrical conductivity of electrolyte solution, the resistance R here was the resistance of the sample solution and represented as R_x from here on in this study, and $\frac{L}{A}$ is defined as the Cell constant (G.M. Barrow, 1973 & 1996).

III. DEVELOPMENT OF HANDMADE CONDUCTIVITY APPARATUS

1. Apparatus setup

<Materials>

A 200 Ω resistor, a 1000 Ω resistor, a variable resistor, a piezoelectric buzzer, carbon rods, film canister, electric wire, crocodile clips, stiff paper and tape.

<Set up>

Variable resistor: Variable resistor here is a resistor which can be adjusted to any desired resistance. A volume adjuster that had a resistance range from 0 - 300 Ω was used as variable resistor. A circle of stiff paper was fixed onto the volume adjuster and an iron wire attached on the axis perpendicularly to indicate the value of resistance on the round paper. Resistance values were marked on the round stiff paper by measurement with a multimeter (Fig. 4-1).



(a)



(b)

Fig. 4-1. Variable resistor seen from (a) the bottom and (b) the top

Electrode cell: A film canister with an inner diameter of 3.0 cm was used as electrode cell and carbon rods taken from a dry cell core were used as electrodes (**Fig. 4-2**). The distance between the two electrodes was 2.0 cm. To fix the electrodes in position, a styrofoam block was used to separate the two carbon rods and tied with tape. To make a constant depth of electrode in solution, the ends of the electrodes were wrapped in tape, leaving 2.0 cm at the end unwrapped as in **Fig. 4-2(a)**. Two holes on the cap of the film canister were made and the two electrode rods were inserted through them. This made the electrode ends project into the case when we closed it as in **Fig. 4-2(b)**.



(a)



(b)

Fig. 4-2. (a) Electrode cell and (b) Electrode cell when closed

Piezoelectric buzzer as bridge: A piezoelectric buzzer (abbreviated to buzzer) was used as a bridge to detect the electric current. The sound from the buzzer played an important role in finding the resistance of sample solution in the handmade device. Each component of apparatus was assembled as shown in **Fig. 3** below.

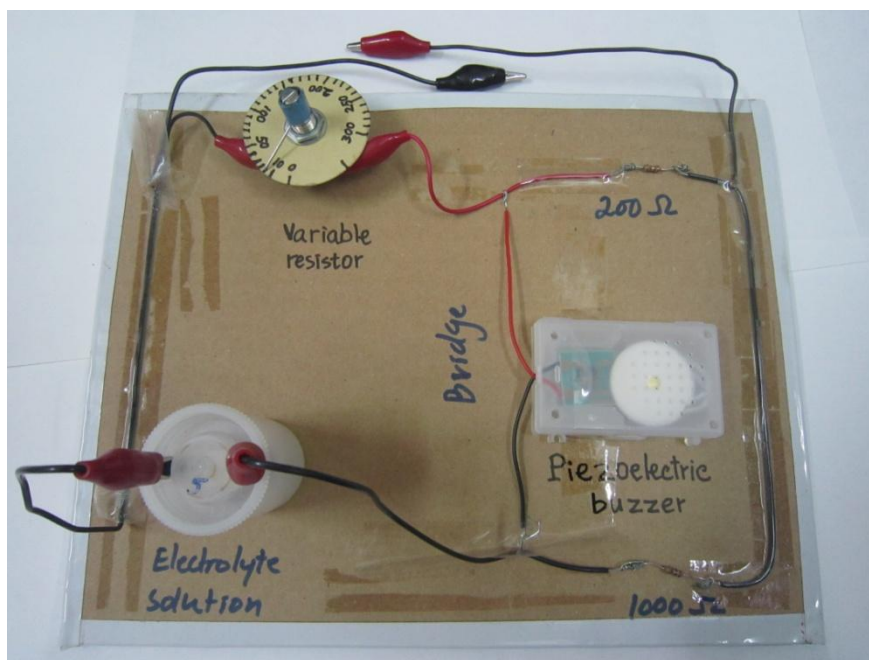

Fig. 4-3. The handmade conductivity meter

The power source we used was an AC variable transformer set to 10 V, which was the lowest voltage needed for our apparatus to produce a sound.

2. Calculation of the Resistance of Sample

Fig. 4-4 illustrates how the resistance of the sample solution was calculated. R_X is the unknown resistance whose value is to be determined. In the condition that there is no difference of electric potential between AB and AC, that means $E_{AB} = E_{AC}$ (by Ohm's law $E_{AB} = I_1R_1$) then the buzzer does not make sound.

In this condition, that circuit constitutes a parallel connection, so we can write:

$$I_1R_1 + I_1R_2 = 10 \text{ V}$$

and $I_2R_X + I_2R_3 = 10 \text{ V}$, Then

$$I_1 R_1 + I_1 R_2 = I_2 R_X + I_2 R_3 = 10 \text{ V} \quad (1)$$

Through the condition that $E_{AB} = E_{AC}$ it means:

$$I_1 R_1 = I_2 R_X \quad (2)$$

$$I_1 R_2 = I_2 R_3 \quad (3)$$

Dividing $\frac{I_1 R_1}{I_1 R_2}$ is equal to $\frac{I_2 R_X}{I_2 R_3}$ so we obtain $\frac{I_1 R_1}{I_1 R_2} = \frac{I_2 R_X}{I_2 R_3}$ (4)

$$\text{Therefore, } R_X = R_3 \frac{R_1}{R_2} \quad (5)$$

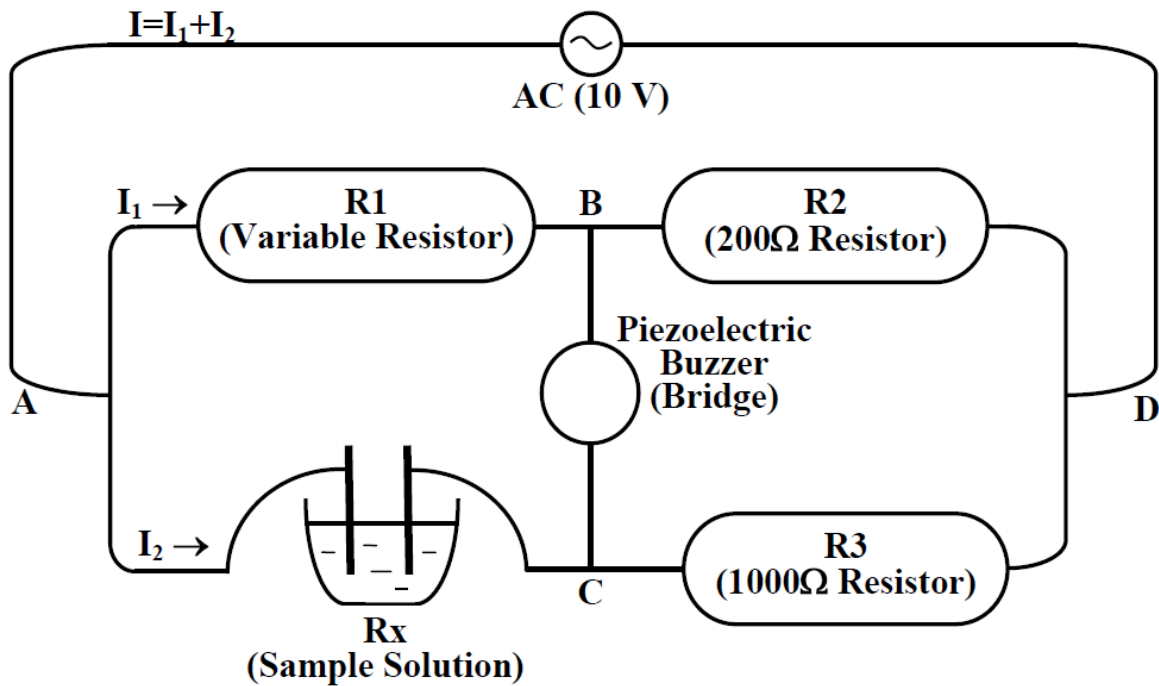

Fig. 4-4. Diagram of the handmade conductivity meter

By replacing the values of R_2 as 200Ω and R_3 as 1000Ω in the equation (5), we are able to find the R_X that is $R_X = 5R_1$ (6)

Here R_1 is a variable resistor whose value varies depending on the sample solution we use.

<Finding the value of variable resistor (R_I)>

The value of variable resistor (R_I) is the average value of the no-sound interval. In measuring the resistance of one sample solution, the variable resistor was first turned to zero. With an appropriate concentration of sample solution, sound could be heard from the buzzer. Then resistor pointer was turned to the higher value on resistor until there was no sound from buzzer. On the round stiff paper of the resistor, there was an interval region of no sound from buzzer; meaning that when the pointer was further turned forward the sound could be heard again at another point. The value of resistance at the first point that the buzzer made no sound was designated R_{low} , and the second point that the sound started again was designated as R_{high} . Then the value of variable resistor (R_I) could be derived from the average of R_{low} and R_{high} , that was $R_I = \frac{R_{low} + R_{high}}{2}$.

For instance in measuring the resistance of crushed carrot solution, when the resistance value of the variable resistor was increased from zero until the buzzer made no sound, the value of the resistance was found 20 Ω , that was R_{low} . As the resistance of the resistor was further increased until the sound could be heard again, the value of the resistance was found 48 Ω , that was R_{high} . So the value of R_I was calculated as:

$$R_I = \frac{20 + 48}{2} = 34 \Omega$$

By finding the R_I , the resistance of crushed radish solution (R_X) also could be deduced as: $R_X = 5 R_I$

$$= 5 \times 34 \Omega = 170 \Omega$$

Through Equation 6 mentioned above, the conductivity of a solution can be calculated by the relationship $\kappa = \frac{L}{A} \times \frac{1}{R_X}$ (7)

where R_X is the resistance of sample solution, and $\frac{L}{A}$ is defined as *cell constant*.

3. Determination of the cell constant

For any given cell, the ratio (L/A) is a fixed quantity. To obtain the value of the cell constant it is not necessary to determine L and A . Instead, a solution of known κ is put in the cell, the resistance is measured and the cell constant is calculated from:

$$\text{Cell constant} = \kappa R_X \quad (8)$$

Once the cell constant is available, the electrical conductivity of any other solution whose resistance is measured in the same cell can be calculated from:

$$\kappa = \frac{\text{Cell constant}}{R_X} \quad (9)$$

The cell constant is almost always determined by using a solution of KCl whose electrical conductivity is known. In this study 50 mM KCl(aq) was used to determine the cell constant. By the handmade conductivity apparatus, R_{low} and R_{high} were found 28 Ω and 52 Ω respectively. Therefore the variable resistance, R_I , was 40 Ω as the midpoint between R_{low} and R_{high} . Then, the resistance R_X of 50 mM KCl (aq) solution could be calculated as 2.0 x102 Ω by Equation (6). Finally the cell constant value was found to be 1.3 cm^{-1} by using Equation (8).

In this study, we produced some electrode cells for groups of high school students to conduct practical work, so the resistance of KCl solution of each electrode cell was measured to determine its cell constant. Because the conductivity meters were developed by hand and used local materials, they were not all exactly the same. This made the values of cell constant of each electrode cell a little bit different from one to the other.

IV. APPLICATION OF HAND-MADE APPARATUS IN MEASUREMENT

1. Measuring the conductivity of electrolyte solutions

After determining the cell constant, the conductivity of NaCl(aq) was measured by starting from the lowest concentration of 10 mM. This procedure was the same as the procedure for determining the cell constant. The difference was just the replacement of sample solutions. **Table 4-1** shows the results of these measurements. Finding the resistance of the electrolyte solutions led to the calculation of their electrical conductivities.

Table 4-1. Results of electrical conductivity of electrolyte solutions

Electrolyte solutions	R_{low} (Ω)	R_{high} (Ω)	R_I : midpoint between R_{low} and R_{high} (Ω)	$R_X = 5 R_I$ (Ω)	Conductivity κ /S cm ⁻¹
0.010 M NaCl(aq)	155	215	185	925	0.0014
0.012 M NaCl(aq)	133	185	159	795	0.0016
0.014 M NaCl(aq)	115	159	137	685	0.0019
0.006 M CuCl ₂ (aq)	130	208	169	845	0.0015
0.008 M CuCl ₂ (aq)	94	150	122	610	0.0021
0.010 M CuCl ₂ (aq)	74	120	97	485	0.0027
0.006 M AlCl ₃ (aq)	96	150	123	615	0.0021
0.008 M AlCl ₃ (aq)	70	112	91	455	0.0029
0.010 M AlCl ₃ (aq)	66	90	78	390	0.0033

In order to verify the results from the developed handmade conductivity meter, the sample solutions were measured by using a commercial **Shimadzu portable Kohlrausch bridge BF-62A** and the results were used for comparison, as in **Table 4-2** and **Fig.4-5**. The results of measurement by using the developed handmade meter showed much consistent with the Shimadzu portable Kohlrausch bridge BF-62A, a commercial meter.

Table 4-2: Conductivities by handmade apparatus and by commercial Shimadzu portable Kohlrausch bridge BF-62A

Electrolyte solutions	Conductivity $\kappa/S\text{ cm}^{-1}$	
	Handmade conductivity apparatus	Shimadzu portable Kohlrausch bridge BF-62A
0.010 M NaCl(aq)	0.0014	0.00130
0.012 M NaCl(aq)	0.0016	0.00150
0.014 M NaCl(aq)	0.0019	0.00170
0.006 M CuCl ₂ (aq)	0.0015	0.00148
0.008 M CuCl ₂ (aq)	0.0021	0.00192
0.010 M CuCl ₂ (aq)	0.0027	0.00242
0.006 M AlCl ₃ (aq)	0.0021	0.00219
0.008 M AlCl ₃ (aq)	0.0029	0.00283
0.010 M AlCl ₃ (aq)	0.0033	0.00344

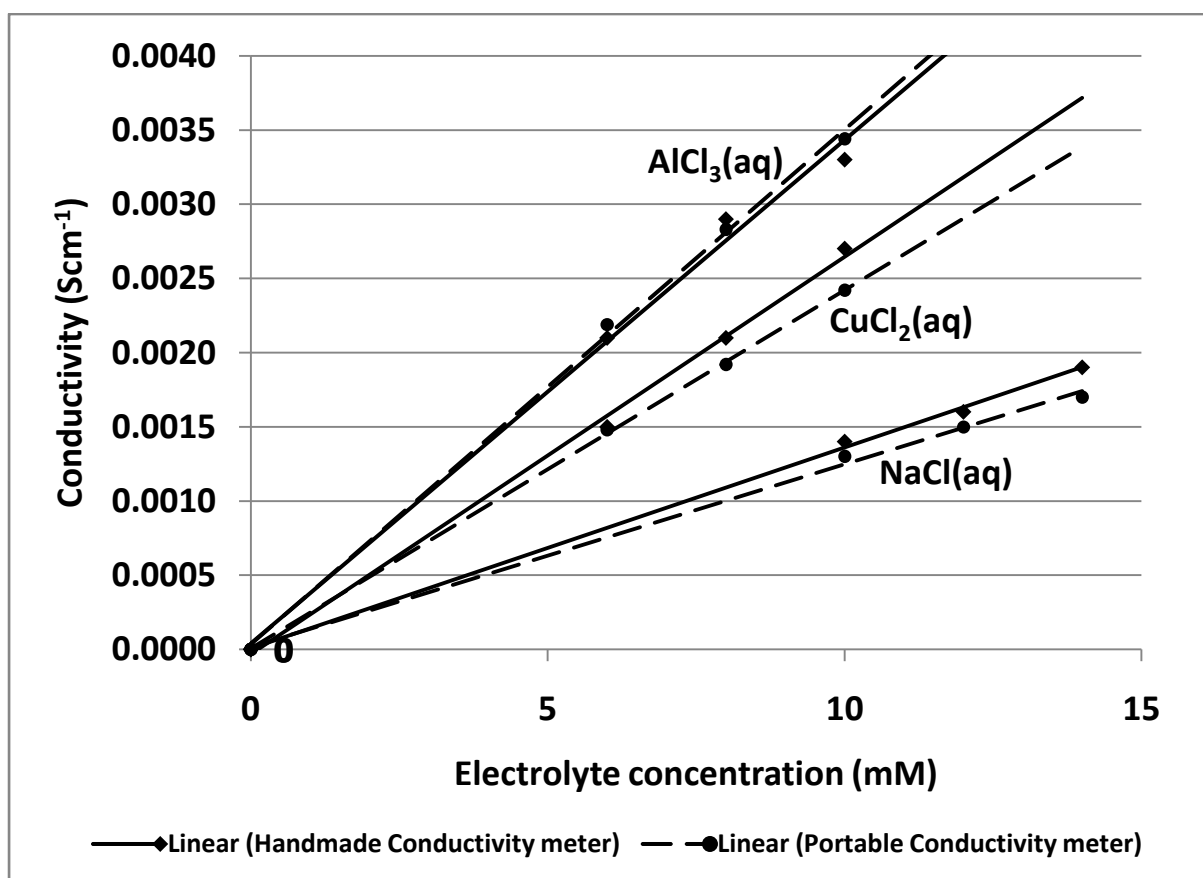

Fig. 4-5. Electrical conductivity of NaCl(aq), CuCl₂(aq), and AlCl₃(aq)

2. Measurement of Conductivity of vegetables, fruit juice solution and drinks

The conductivity of several common vegetables, fruit juices and sports drink (Japanese products) was measured. Carrot, radish, cabbage, apple, orange, Pocari Sweat (sports drink), tea, coffee (Suntory Boss brand), tap water and river water were used for measuring their electrical conductivities.

<Preparing the vegetables and fruit juice solutions>

For drinks and river water, measurements were conducted directly from the original container and source. In preparing solutions that were from vegetables and fruits, for example apple, the solution was prepared as follow:

1. An apple was sliced and then 20 g of sliced apple was ground by using a mortar and pestle.
2. 20 mL of water was added to the ground apple in the mortar.
3. The apple in the mortar was continuously ground and stirred for one minute.
4. After stirring, the ground apple solution was filtered and kept for measuring its resistance.

The same procedure was applied for other vegetables and fruits.

In this research, the measurements were conducted at different times with the different electrode cell, so from time to time before starting new measurements the cell constant was determined again. After some improvements of the handmade conductivity meter, a solution of KCl(aq) at 10 mM could be used for determining the cell constant with a new electrode cell.

<Determine the cell constant>

This time, the standard solution of 10 mM of KCl(aq) was used to determine the cell constant. In this case, R_{low} and R_{high} were 65 Ω and 115 Ω respectively given by the

handmade conductivity measurement apparatus. Thus, R_I as the midpoint between the two resistances was determined as 90 Ω . Hence, R_X was calculated to $4.5 \times 10^2 \Omega$. The conductivity of 10 mM KCl(aq) is known as $0.0014114 \text{ S cm}^{-1}$ (a standard solution). Therefore, the new cell constant was found to be 0.64 cm^{-1} by using Equation (8).

Even though the value of cell constant was different from the previous one, the results of electrical conductivities were almost the same as previously. With this change of cell constant value, the measurements of electrical conductivities of NaCl(aq) with different concentration were once again conducted in order to check and verify before measuring vegetables and fruit juices. The results of this verification are shown in **Table 4-3** and **Table 4-4** below.

Table 4-3. Verification of the cell constant value with NaCl(aq) standards

Electrolyte solutions	R_{low} (Ω)	R_{high} (Ω)	R_I : midpoint between R_{low} and R_{high} (Ω)	$R_X = 5 R_I$ (Ω)	Conductivity $\kappa/\text{S cm}^{-1}$
0.010 M NaCl(aq)	70	116	93	4.6×10^2	0.0014
0.012 M NaCl(aq)	65	95	80	4.0×10^2	0.0016
0.014 M NaCl(aq)	62	80	71	3.6×10^2	0.0018

Table 4-4. Conductivities by handmade apparatus and by commercial apparatus Shimadzu portable Kohlrausch bridge BF-62A

Electrolyte solutions	Conductivity $\kappa/\text{S cm}^{-1}$	
	Handmade conductivity meter	Shimadzu portable Kohlrausch bridge BF-62A
0.010 M NaCl(aq)	0.0014	0.00132
0.012 M NaCl(aq)	0.0016	0.00153
0.014 M NaCl(aq)	0.0018	0.00172

After the sample solutions of vegetables and fruits were prepared, their resistances were measured by the same procedure as the conductivity of electrolyte solutions. The measurements started from the apple sample solution. The results of measurements are shown in **Table 4-5** and **Table 4-6** below.

Table 4-5. Results of electrical conductivities of vegetables and fruits

Sample	R_{low} (Ω)	R_{high} (Ω)	R_I : midpoint between R_{low} and R_{high} (Ω)	$R_X = 5 R_I$ (Ω)	Conductivity $\kappa/S\text{ cm}^{-1}$
Carrot	20	48	34	1.7×10^2	0.0038
Radish	25	80	53	2.7×10^2	0.0024
Cabbage	30	80	55	2.8×10^2	0.0023
Orange	50	136	93	4.6×10^2	0.0014
Apple	86	170	128	6.4×10^2	0.0010
Pocari Sweat	50	76	63	3.1×10^2	0.0020
Coffee*	45	63	54	2.7×10^2	0.0046
Tea	**	**	**	**	**
River water	**	**	**	**	**
Tap water	**	**	**	**	**

* Measured with the cell constant value of 1.24 cm^{-1}

** Resistances of these samples were too large for the handmade apparatus to measure.

Table 4-6: Electrical conductivities of vegetables and fruits solution by handmade apparatus compared with commercial apparatus

Electrolyte solutions	Conductivity $\kappa/S\text{ cm}^{-1}$	
	Handmade conductivity meter	Shimadzu portable Kohlrausch bridge BF-62A
Carrot	0.0038	0.00368
Radish	0.0024	0.00243
Cabbage	0.0023	0.00227
Orange	0.0014	0.00136
Apple	0.0010	0.000971
Pocari Sweat	0.0020	0.00196
Coffee	0.0046	0.00425
Tea*	*	0.00059
River water	**	**
Tap water	**	**

Note:

* **Shimadzu portable Kohlrausch bridge BF-62A** could measure, but handmade apparatus could not measure,

** Resistances of the samples were too large for either the **Shimadzu portable Kohlrausch bridge BF-62A** or handmade apparatus to measure.

3. Confirmation by Titration of vegetables and fruits

To verify the amount of electrolyte in vegetables and fruits whose electrical conductivity was measured, a titration was also carried out. In each titration we used the same mass (20 g) of sample as used when measuring its electrical conductivity.

In preparing ash solution from vegetables and fruits, for instance apple, first 20 g of fresh apple was burnt until it became ash. 50 mL of water was added to the ash in a beaker and then stirred and filtered to get an ash solution. The results from the titrations were converted to the total contents of alkali in 1 g of the fresh vegetable and fruit (Table 4-7). Then, they were plotted versus to their conductivities as shown in Fig. 4-5. The results show that the conductivity of each fruit solution was consistent with its total contents shown by the titration. This means the hand-made conductivity can be used to examine the conductivity of the fruit solutions and assume to their total dissolved contents.

Table 4-7. The results of the titration

Ash solution	Volume of 10 mM HCl(aq) used to reach equivalent point (mL)	Concentration of total alkalis, Cb/mM	Total alkali content in 1 g of vegetable or fruit /mol.g ⁻¹
Carrot	22.4	11.2	2.80x10 ⁻⁵
Radish	10.5	5.25	1.31x10 ⁻⁵
Cabbage	8.0	4.0	1.00x10 ⁻⁵
Orange	6.2	3.1	0.78x10 ⁻⁵
Apple	5.7	2.9	0.73x10 ⁻⁵

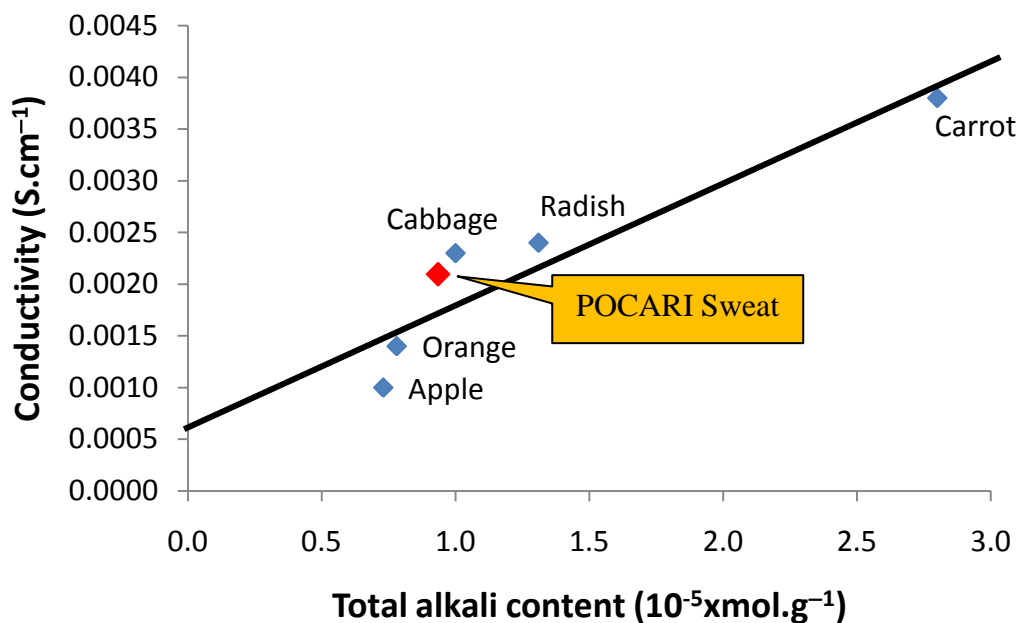

Fig. 4-6. Alkali contents in vegetable and fruit versus the conductivities

Based on the correlations shown in **Fig. 4-6**, it can be assumed that the total contents in the sport drink like Pocari Sweat is about less than $1.0 \times 10^{-5} \text{ mol/g}$. This is even below Cabbage juice, Radish juice and Carrot juice, due to its conductivity is only 0.0020 S.cm^{-1} .

V. APPLICATION TO CLASSROOM

1. Lesson Instruction

The handmade apparatus was introduced to a class of 10 students in Japan and that of 40 students in Cambodia in eleventh grade through lessons on conductivity of electrolyte solutions aiming to evaluate its potential and applicability in a real classroom. The lessons were conducted in four periods while each period the students needed approximately 25 minutes to complete the given experimental activity by groups. However, the first period was solely used for the lesson introduction to explain relevant and important background information on electrolytes, conductivity, and the Kohlrausch bridge principle. Students were given some hints on how to find to calculate the conductivity by interpreting the conductivity equation and how to determine the cell constant, as well as measurement procedures. The

following three periods the students examined the conductivity of electrolyte solutions, the conductivity of vegetable and fruit juice solutions, and acid-base titration for vegetable and fruit ashes. All the sample solutions and materials were readily prepared for students before the lessons. Finally, the students were able to obtain the same results as shown in **Table 4-6** and **Table 4-7**. Though, the results from the portable conductivity meter (Shimadzu portable Kohlrausch Bridge BF-62A) were measured by the instructor.

Before the experiment, students were asked to predict and explain what would happen to the conductivity when the concentration of electrolyte in solution decreased or increased, based on their background knowledge on how electricity passed through a material. Since Pocari Sweat sports drink is a common drink in Japan that people often use to supplement ions in their body after exercising, the lesson presenter asked students whether people could use vegetable or fruit juices instead of Pocari Sweat sports drink after they did exercise. Such introductory questions were of key importance in the lesson because they effectively motivated students towards scientific investigation. The most impressive activity for students was the conductivity determination of vegetables and fruits. The students could hardly wait to conduct their experiment to find out whether their predictions about whether Pocari Sweat sports drink was better than the vegetable and fruit juices, were correct or not.

As shown in **Fig. 4-5**, the students understood that electrical conductivities for a certain electrolyte solution differed at different concentrations. In particular, they observed that conductivity increased with increasing concentration. They also could reveal clearly that a higher charge of cation showed a higher conductivity at similar concentrations, and that the electrical conductivity of different electrolyte solutions increased with respect to the number of ions dissociated from the species. In **Table 4-5** and **Table 4-6**, the students surprisingly realized that some vegetable and fruit juices such as cabbage, radish and carrot could provide more electrolytes (ions) than Pocari Sweat sports drink. This result surprised the students so

much that they said they would drink juice instead of Pocari Sweat sports drink to supplement ions to their body when they sweat.

The total content of the electrolyte was also revealed to the students through acid-base titration experiments. The students could understand the clear relationship between the total content of the electrolyte, and alkali in the corresponding ash derived solutions (**Fig. 4-6**). In addition, the students learned that although vegetables and fruits contained organic and inorganic substances, they mostly contained inorganic substances when they were burned to ash. They observed the ash solution turned pink when a few drops of phenolphthalein were added, which clearly proved its alkalinity.

2. Evaluation of the developed teaching and learning materials

<Knowledge Improvement>

After the lessons, most of the students could understand the lesson concepts have been taught. Responding to the questionnaires, no one responded “did not understand at all”, but most of them chose “clear understood” and “understood” (**Fig. 4-7**). They improved their knowledge related to the teaching contents significantly while comparing before and after the lesson. As shown in the pre/post test results, most of the students could achieve high scores to each of the questions (**Fig. 4-8**).

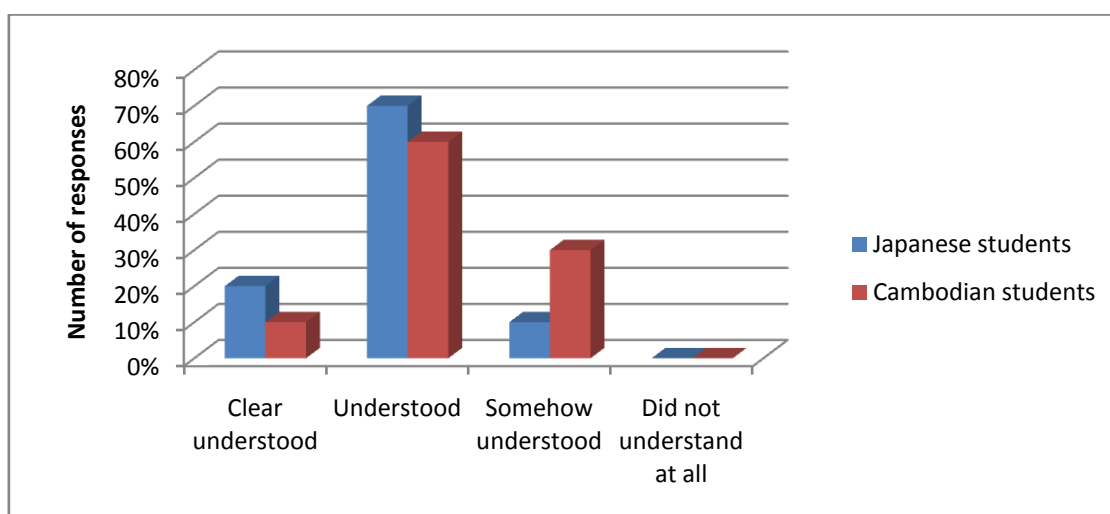

Fig. 4-7. Students evaluated their understanding of the lessons

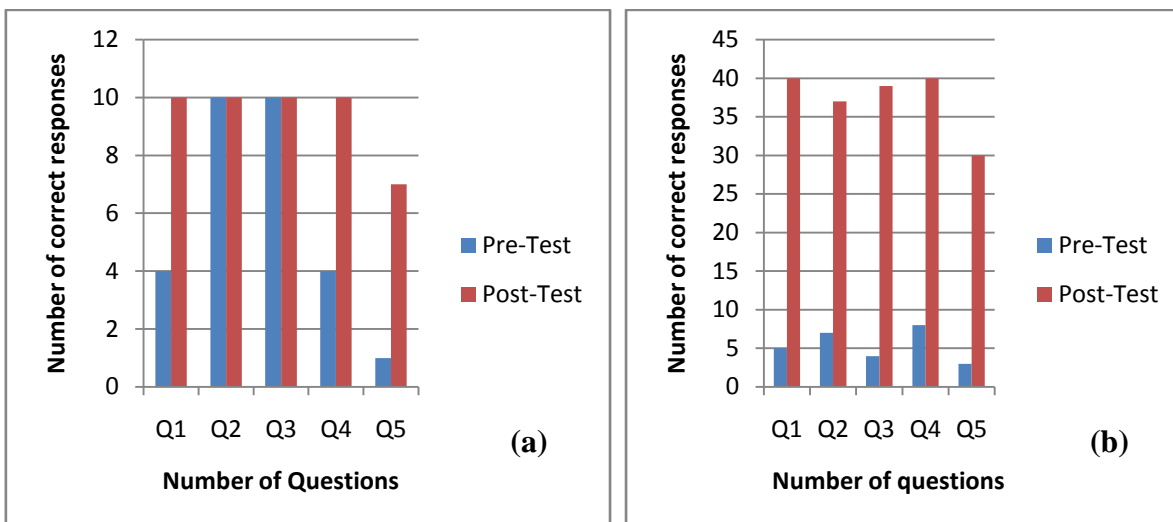

Fig.4-8. Students' performance on pre/post tests: (a) Japanese students, (b) Cambodian students

Q1: Definition of conductivity.
 Q2: Conductivity and concentration of solutes relationship
 Q3: Conductivity and concentration of solutes relationship
 Q4: Conductivity and total contents in environmental water
 Q5: Conductivity and daily drinks
 (The detail questions in Pre/Post Tests are attached in the APPENDIX)

Moreover, the students recognized that they could obtain several skills from the lessons they learned. As shown in **Fig. 4-9**, most of the students learned that carrot and radish contain more ionic contents compared to other fruit and vegetable, and many of them valued the meaning of conductivity and its measurement method as well as the relationship between the conductivity and the dissolved content concentration in the solutions. This is clearly indicated that the students could acquire the concept of conductivity of solution very well by using the developed teaching and learning apparatus and the designed activities.

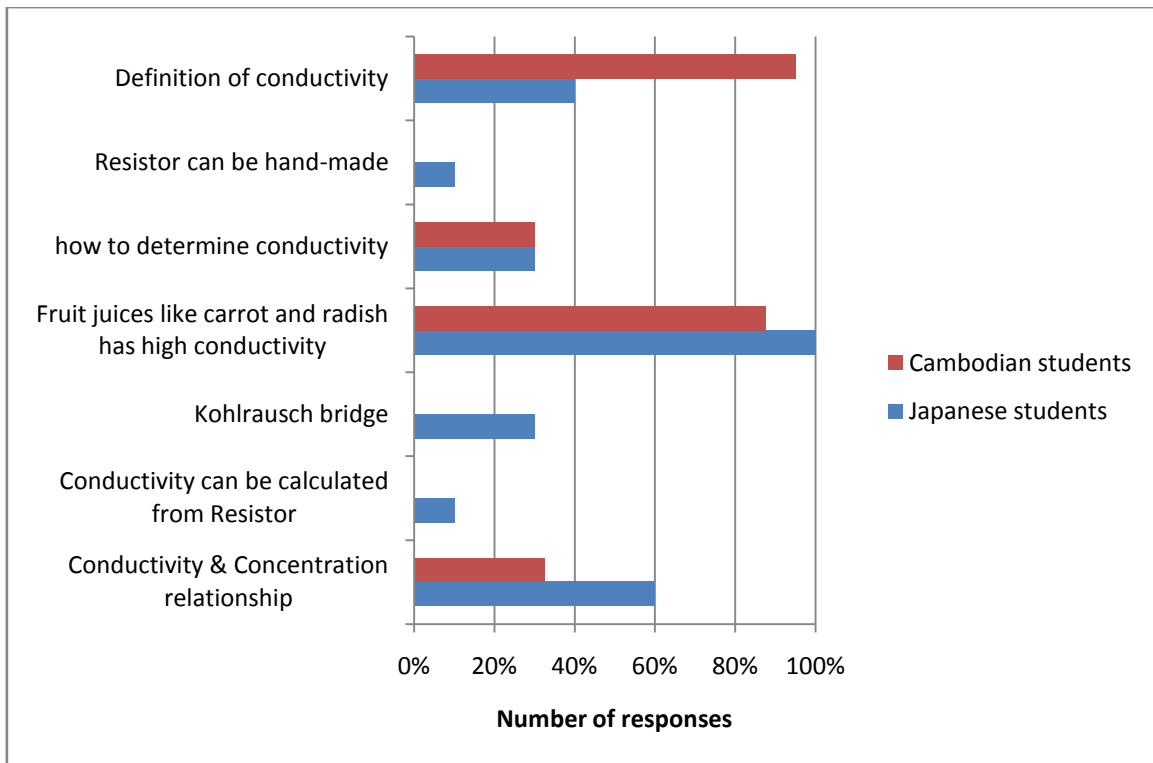

Fig. 4-9. Students claimed their knowledge and skills acquired from the lessons

<Applicability>

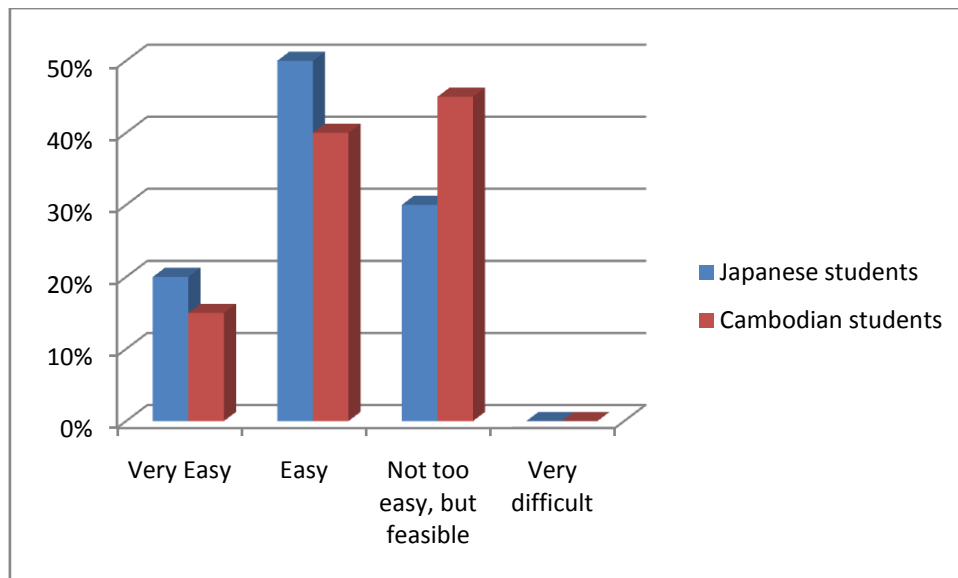

Fig. 4-10. Feasibility of using the hand-made apparatus by the students

In general, the apparatus and activities could be appropriately applied to the students at secondary level in both Japanese and Cambodian classrooms. In the questionnaires, the students responded that they could use the hand-made apparatus without difficulty. Even

though some of them thought that it was not too easy, but feasible, many of them showed it is easy or very easy (**Fig. 4-10**). It could be noticed that, although the procedures of using the handmade apparatus are easy, it constructed based on Kohlrausch bridge which needs physic principle to interpret data. This might cause some difficulty for some students to follow. However, the students still could use the developed apparatus and conduct the activities designed in the lessons to solve the given problem and reach to the lesson objectives. Therefore, it was concluded that the apparatus was feasible to introduce to students in the classroom at this level.

<Students' Satisfaction>

As shown in **Fig. 4.11**, for the students showed that they satisfied the lesson activities as well as the introduced learning apparatus. This means that the use of the developed handmade apparatus could surely encourage students learned more actively and effectively in the classroom.

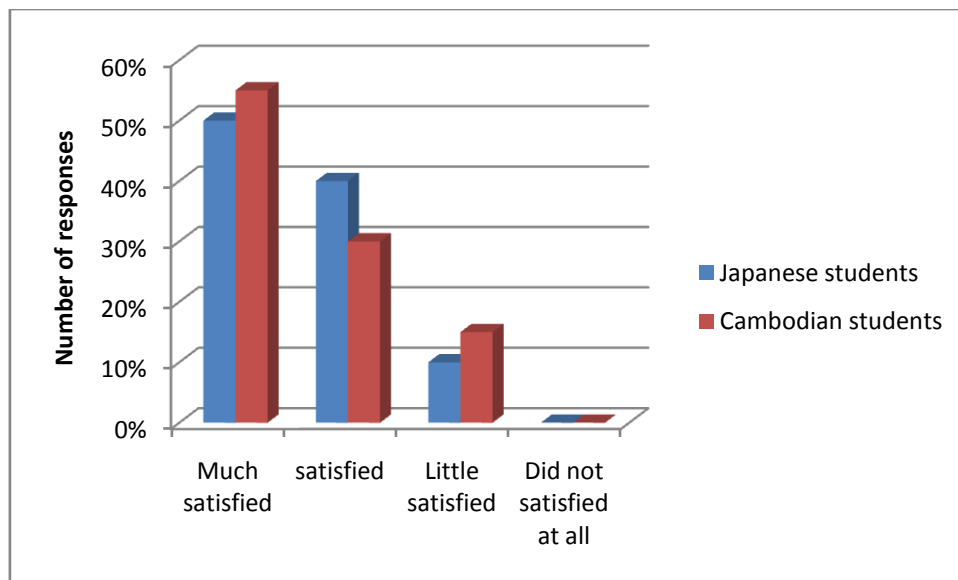

Fig.4-11. Students' satisfaction of the introduced activities and the handmade apparatus.

The followings are common comments given by the students after the lessons:

- I'll use orange juice or vegetable juice instead of POCARI SWEAT
- I am surprised that carrot is better than sport drink.

- I'll suggest my teammates to drink fruit juice instead of POCARI
- I want to examine other material like coke, coffee, tea...
- At first there were many words difficult for me. But today's lesson give me many knowledge.
- Today's lesson is very interesting.
- I am surprised carrot and radish juice has a lot of fun.
- Today's lesson has many things.
- I have never learned this lesson. It is interesting.
- I want to come here again next week.
- I enjoyed and understand today's class.
- Today's experiment was interesting since I am interested in electricity.

VI. CONCLUSION

Electrical conductivity measurement methods are useful for helping students understand electrolytes. The handmade conductivity meter presented here is assembled from inexpensive and available materials in daily life and is easy for teachers and students in high school to assemble and use. Pre- and post-test results showed that the students' understanding of electrolytes improved significantly. Results obtained through measurements using the handmade apparatus were consistent with the results obtained with the Shimadzu portable Kohlrausch bridge BF-62A. Our study showed that, even if different electrode cells resulted in relatively different cell constant values, the calculated final conductivity values were almost the same. Other notable benefits were that this handmade apparatus used only a low voltage AC power source as well as a combination of 200 Ω and 1000 Ω resistors in the circuit, which contributed to the accuracy of the results and safety operation. In addition, this experiment made students aware that apart from traditional laboratory chemical solutions,

everyday drinks can also be used as samples to study electrolytes. The use of everyday drinks such as vegetable and fruit juices in the classroom could considerably enhance students' interest in learning science.

Based on the students' performance in the pre/post tests and their responses to the questionnaires, the handmade conductivity apparatus and the lesson activities presented here could significantly help students actively learning in the chemistry classroom. The introduced lessons could build up students' knowledge and skills in science through the investigation of daily materials, such as juices and drinks. Therefore, it could be recommendable to apply this handmade apparatus and the designed activities to students in the chemistry, as well as in the physics classroom at the secondary levels.

REFERENCES

- Colton, R.; Sketchley, G. J.; Ritchie, I. M.; *J. Chem. Educ.*, **1976**, *53*, pp 130-132
- G.M. Barrow. *Physical chemistry*; 3rd edition; McGraw-Hill: Tokyo, **1973**; pp 617-620.
- G.M. Barrow. *Physical chemistry*; 6th edition; McGraw-Hill: Tokyo, **1996**; pp 361-362.
- Gadek, F. A commercially available device for conductivity experiments. *J. Chem. Educ.*, **1987**, *64*, pp 281-282
- Gadek, F. Easily made electronic device for conductivity experiments. *J. Chem. Educ.*, **1987**, *64*(7), 628-629
- Hans A.; Lorraine Kaelber. Apparatus for the demonstration of conductivity of electrolytes. *J. Chem. Educ.*, **1955**, *32*, p 640
- John W. Havrilla. An inexpensive device for quantitative conductivity experiments. *J. Chem. Educ.*, **1991**, *68*(1), p 80
- Mercer, G. D. A low-cost, portable, and safe apparatus for lecture hall conductivity demonstration. *J. Chem. Educ.*, **1991**, *68*(7), pp 619-620
- P. Atkins; J. de Paula. *ATKINS' PHYSICAL CHEMISTRY*; 8th edition; Oxford University Press: New York, **2006**; pp 761-762.
- Rettich, T.; Battino, R. An inexpensive and easily constructed device for quantitative conductivity experiments. *J. Chem. Educ.*, **1989**, *66*(2), pp 168-169
- Russo, T. A Cheap, Semiquantitative Hand-Held Conductivity Tester. *J. Chem. Educ.*, **1986**, *63*, p 981
- Susan K. S. Zawacky. A Cheap, Semiquantitative Hand-Held Conductivity Tester. *J. Chem. Educ.*, **1995**, *72* (8), p 728
- Vitz, Ed. Conductivity of solutions apparatus. *J. Chem. Educ.*, **1987**, *64*(6), p 550

Chapter V

DEVELOPMENT OF HAND-MADE CONDUCTIVITY

DEVICE FOR THIN-FILM SEMICONDUCTOR

AND

ITS APPLICATION TO STUDY THE EFFECT OF

SURFACTANTS ON CONDUCTIVE PROPERTY OF

POLYPYRROLE

I. INTRODUCTION

Electrical conductivity in polymers is not a common phenomenon but such polymers have been made and are available. Three noble prizes were awarded jointly to Alan J. Heeger, Alan G. MacDiarmid and Hideki Shirakawa in 2000 for their discovery and development of conductive polymers (http, 2000). The conductivity of thin-film semiconductors such as polypyrrole (Ppy) has been a popular topic of discussion since well before the current research. In current technology, electrically conductive plastics are common materials in daily life and are used in electronic devices, chemical sensors and biological applications due to their special properties besides conductivity such as, oxidative polymer structure, stability, and biocompatibility etc.

In particular, Ppy is easily produced by polymerization of pyrrole through electrolysis and doped with various chemicals (dopants) in the laboratory (Ramanaviciene, 2006). Several researchers have suggested simple procedures for producing conductive Ppy electrochemically by using several kinds of dopant compounds, both organic and inorganic, and have studied their electrical properties (street, 1983; Kang, 2000; Rhee, 1989, Kupila, 1993; Crayston, 1992; Saville, 2005; Steven, 1993; Bunting, 1997; Morales, 2000; Puanglek, 2010). Among the above methods, the conductive Ppy was synthesized simply through the electrolysis of aqueous pyrrole solution in the presence of surfactant such as sodium dodecyl sulfate (SDS) as dopant. However, the methods used to determine the conductivity of the Ppy in the above mentioned research required complex techniques, expensive devices, and some used computer-controlled software. These methods are not suitable for introduction into high school lessons. Others have used simple methods to study Ppy conductivity by measuring the electrical resistance of the conductive film by direct ohmmeter measurements (Steven, 1993; Bunting, 1997; Morales, 2000) or by observing the electric current passing through the conductive polymer by using a two-point probe technique (Puanglek, 2010). Such techniques

are thought to be suitable for application in classrooms due to their ease of use by students. However, the measurement of conductivity of a thin semiconductor such as Ppy by using the two-point probe method is not considered to provide accurate results, especially for thin semiconductor films with relatively high conductivity (Li, 2012). This is because the two-probe technique uses direct and strong current, which easily destroys or changes the properties of the thin film. Also, contact resistances between the metal probes and semiconductor material as well as wire resistances in the whole circuit contribute to errors that result from the low resistivity of the semiconductor material.

To obtain more accurate conductivity values for thin semiconductor films, researchers have suggested using a four-point probe technique, (Li, 2012; Konkov, 1965) sometimes also called four-wire sensing or four-terminal sensing. The four-probe technique could reduce the errors caused by contact resistances and the strong current passing through the semiconductor films. Even though several researches have used the four-point probe technique to characterize the electrical properties of semiconductors such as Ppy, (Kang, 2000; Morales, 2000; Li, 2012; Joo, 2006; Hasiah, 2008) they have used modern commercial instruments, which are expensive and not easy to introduce in high school classrooms.

This paper describes the development of a simple, handmade conductivity measurement device based on the principle of the four-point probe technique, from inexpensive and available materials and its application to measuring the conductivity of Ppy films. At the same time, the effect of surfactants on the electrical properties of polypyrrole (Ppy) is also discussed. The accuracy of this device and its effectiveness as a teaching material in high school lessons, were determined.

II. CONDUCTIVITY OF MATERIALS

The conductivity of a conductive material is generally determined by its electrical resistivity, which is closely related to its physical binding properties. The binding properties of molecules determine the availability of free electrons within a material and the availability of free electrons determines the electrical resistivity of the material. Many researchers have studied the electrical properties of materials by measuring their electrical resistivity and hence determined their conductivity. In such studies, semiconductors are good subjects due to the strong effect of their varying compositions on electrical resistivity.

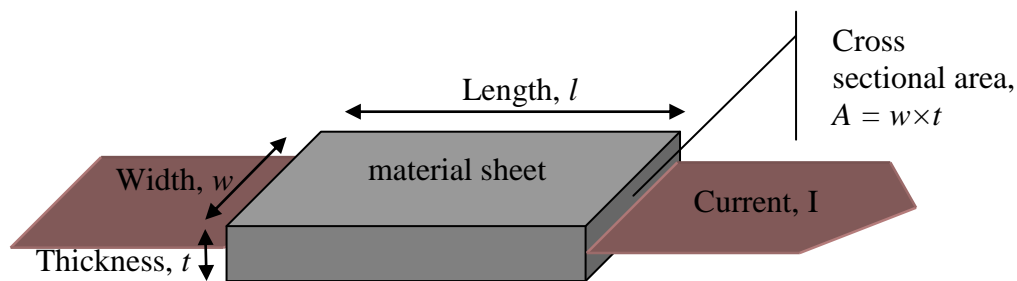

Fig. 5-1. Illustration of passing current through a thin film material

Basic physics tells us that the resistivity of a material can be determined from its resistance. When a current, I , passes through a thin film of cross sectional area, A , over a distance, l , and a voltage difference, V , between the two cross sectional areas (**Fig. 5-1**), then the film resistance, R , is determined by.

$$R = \rho \frac{l}{A} = \rho \frac{l}{wt}, \text{ where } \rho \text{ is resistivity of the film.}$$

Therefore, resistivity can be written as $\rho = \frac{Rwt}{l}$ (1)

Conductivity of the film, κ , is defined as the inverse value of its resistivity. Therefore,

$$\kappa = \frac{1}{\rho} \text{ or } \kappa = \frac{l}{Rwt} (2)$$

Where R is in Ω and can be calculated from Ohm's Law ($R = \frac{V}{I}$, V is voltage in V and I is current in A), l , w , t are in cm. Therefore, conductivity, κ , is determined in $\Omega^{-1}\text{cm}^{-1}$ or S/cm (S is Siemens, where $1\text{S} = 1\ \Omega^{-1}$).

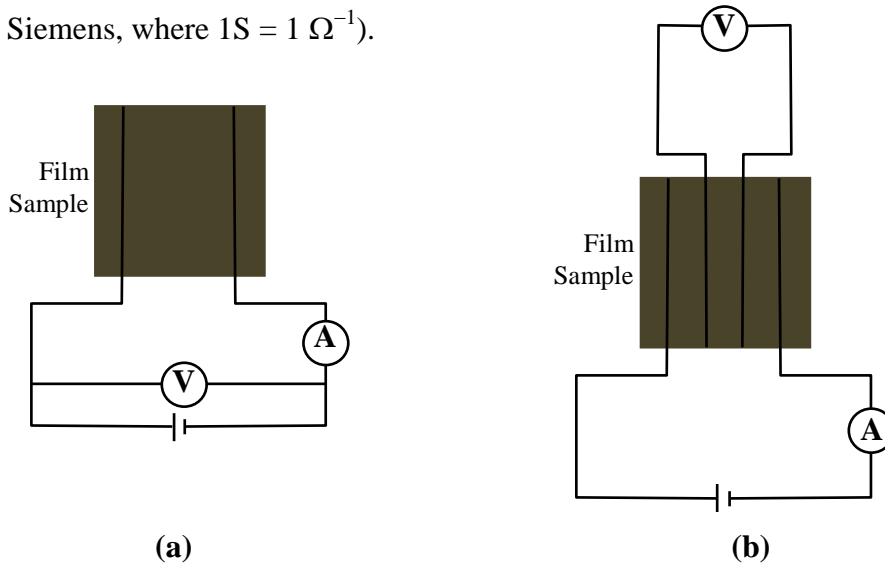

Fig. 5-2. (a) Two-point probe technique, (b) four-point probe technique

Although the above description shows how to determine the conductivity of a thin film theoretically, practically there are quite different advantages and disadvantages from one technique to another. To determine the electrical conductivity of a thin film with a high resistivity (from 1M ohm/sq), a simple two point probe technique in which current and voltage are measured in the same line (**Fig. 5-2a**), can be used because **contact and spreading resistances** contributed by the circuit are negligible. However, this technique is not accurate for measuring materials of low resistivity, such as semiconductors, since in this case contact and spreading resistances are close to the sample resistance. To reduce such errors and obtain highly accurate measurements, a four-point probe technique is suggested (Li, 2012; Konkov, 1965). Sometimes, it is called four-terminal sensing or four-wire sensing.

The four-point probe technique involves separating the current and voltage circuits (Fig. 5-2b). In this technique, the voltage of the sample is measured with negligible current. Therefore, there is no potential difference from the wires, and contact and spreading resistances are not high. So the voltage drop caused by Ohms Law is extremely low. This is

especially suitable for semiconductor films, in which resistivity is generally low. Thus highly accurate measurements can be made.

III. DEVELOPMENT OF A HAND-MADE DEVICE

The four-point probe technique is conventionally set up in micro scale using silver paste to attach each platinum wire probe onto a small sample of semiconductor film. **Fig. 5-3a** (taken with a microscope), is an example of a conventional four-point probe technique in which the four probes are attached to a small sample of film (*ca.* $4.5 \times 2.0\text{mm}$) with silver paste. This must be carried out using a microscope and takes time and much care to complete each probe. In order to avoid such complicated work, we developed a simpler, more convenient handmade device using the four-point probe technique in which current and voltage sensing were separated. The device was simply assembled from cheap materials (**Fig. 5-3b**).

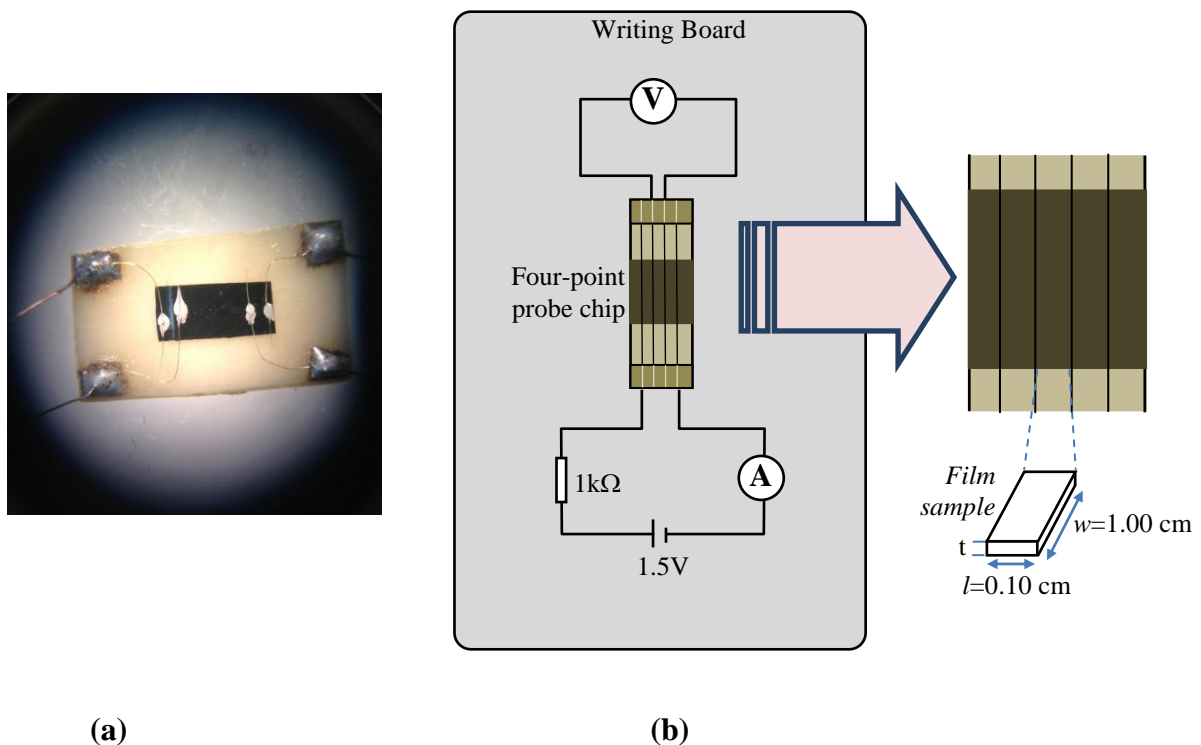

Fig. 5-3.(a) Conventional 4 point probe technique setup (black rectangle is Ppy film), (b) diagram of handmade device setup

The most important part of the device is the four-point probe chip, which needs careful preparation. However, we didn't need a microscope and neither lead nor silver paste to construct it. In this case, a piece of plastic from daily life (like a food container) was cut to size 4.50×1.00 cm. Four Be-Cu wires ($d=0.20$ mm) were laid along the plastic strip separated by a distance of 0.10 cm between each wire and held firmly in place by tape and glue at each end to prevent them from touching each other (**Fig. 5-3b** and **Fig. 5-4a**). After the four-point probe chip was prepared, it was connected into the circuit as showed in **Fig. 5-3b**. The chip was attached to a plastic block (*ca.* $1.00 \times 1.25 \times 0.50$ cm), so that one end of the chip was in contact with the board and the other end was raised (**Fig. 5-4b**). In order to prevent a strong current passing through the thin-film sample, a fixed $1k\Omega$ resistor was used in the current sensing circuit. Two digital multimeters were used, one for detecting current and the other for detecting voltage. The device was powered by a 1.5V DC power source. A DC electric transformer is recommended rather than a dry cell since it can provide more stable current and does not contribute contact resistance to the circuit.

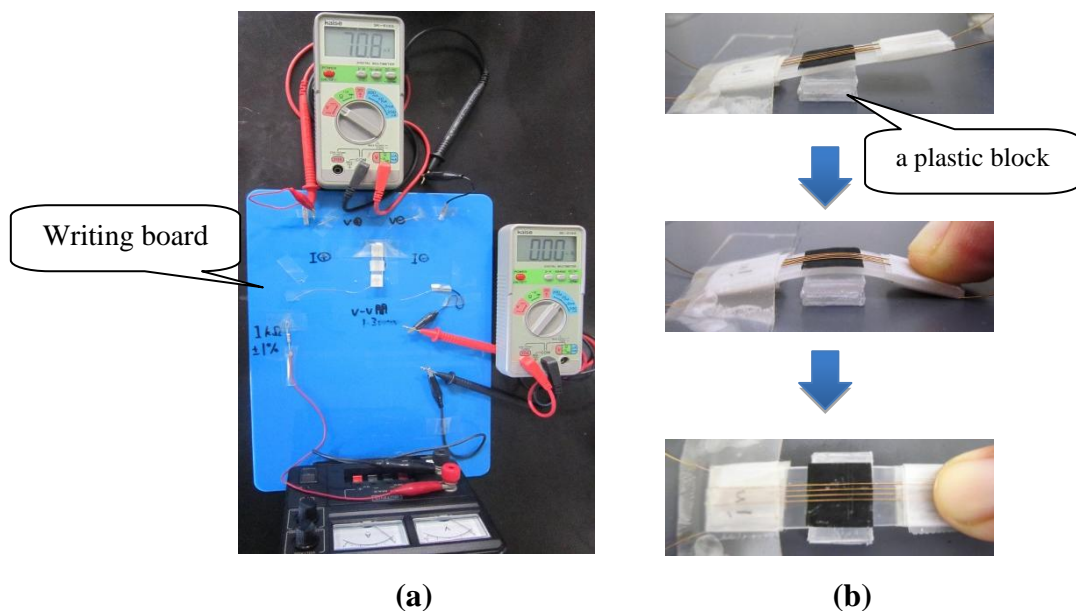

Figure 5-4. (a) Assembly of handmade device, (b) four-point probe chip installation and its operation

With the handmade device, we could obtain voltage and current values by using multimeters. The film thickness could be simply measured with micro calipers, while l was set at a fixed value of 0.10cm. If the film sample was cut to a width, w , of 1.00cm, then the conductivity value of the sample could be calculated from the following relationship obtained from equation (2).

$$\kappa = \frac{0.10}{Rt} \quad (3)$$

IV. APPLICATION TO POLYPYRROLE CONDUCTIVE PROPERTY

The hand-made device was used to study the electrical properties of Ppy. In this study, several types of Ppy were prepared through electrolysis in the presence of different kinds and concentrations of surfactants. The study aimed to understand how anionic and neutral surfactants affect the electrical properties of Ppy.

1. Polypyrrole

Electrical conductivity in polymers is not a common phenomenon but such polymers have been made and are available. Ppy is a typical conductive organic polymer formed by polymerization of pyrrole monomer. It is a well-known polymer in current science and technology research. The first report of Ppy was in 1963 by Weiss and his coworkers who found that the pyrolysis of tetraiodopyrrole could produce highly conductive materials (McNeill, 1963). Three noble prizes were awarded jointly to Alan J. Heeger, Alan G. MacDiarmid and Hideki Shirakawa in 2000 for their discovery (http, 2000) and development of conductive polymers. Later research focused on polypyrrole's special properties such as being a good semiconductor, and its stability and biocompatibility (Ramanaviciene, 2006). Nowadays Ppy is commonly used in electronic devices, such as chemical sensors, bio- and immuno-sensors. etc.

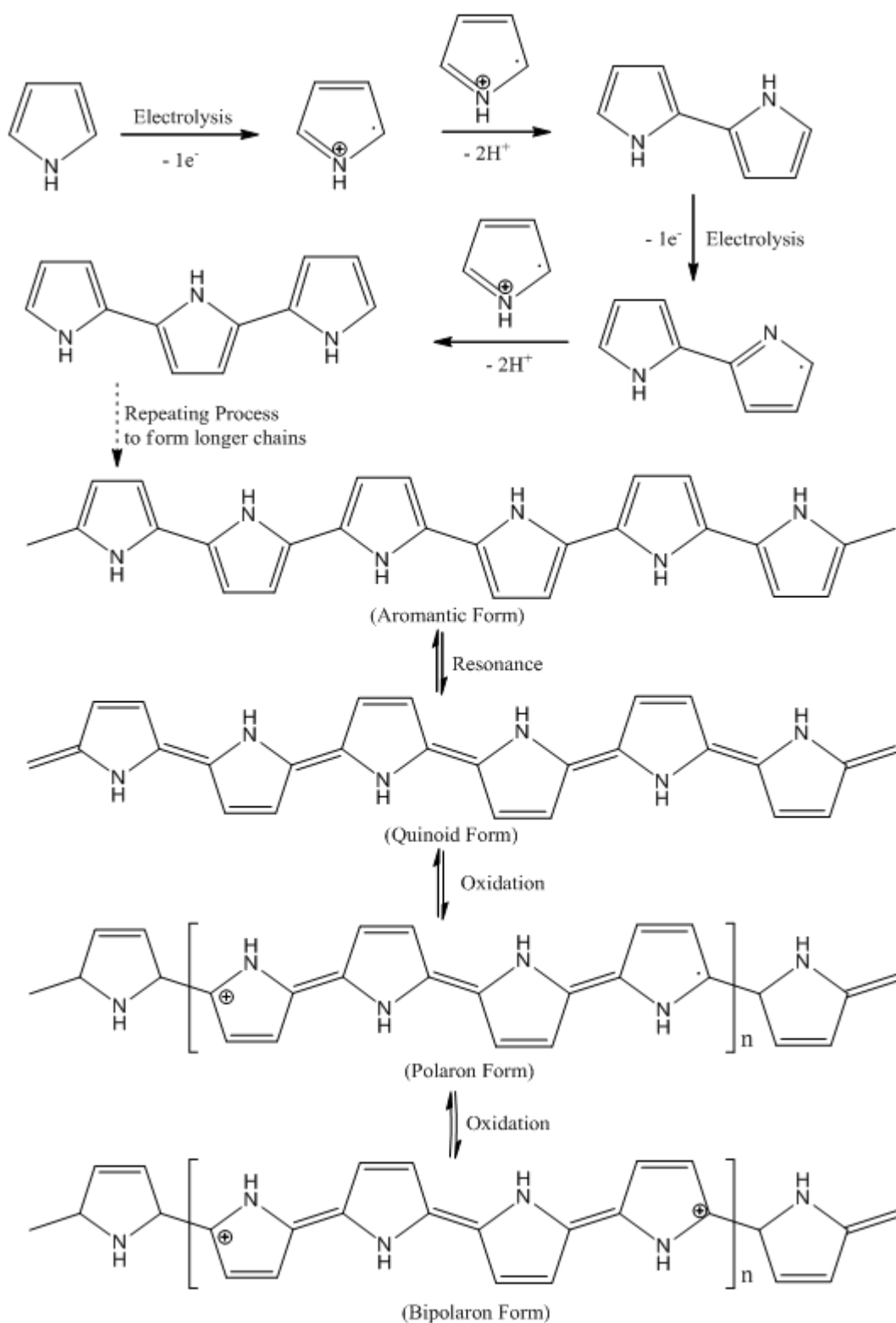

Fig. 5-5. Polypyrrole formation and its non-conductive and conductive forms

Polymerization of pyrrole is considered to occur through the formation of the pi-radical cation produced by the oxidation of pyrrole molecules (Fig. 5-5). Through oxidation, for instance during electrolysis, a pyrrole molecule loses one electron and becomes a radical

cation at C-2 carbon of the pyrrole molecule. The radical cation then combines with another radical cation to form the 2,2-bipyrrole. This process is then repeated to form longer chains such as polypyrrole.

The polymer has two resonance structures, an *aromatic* or *quinoid* form. Like other polymers, these two forms are not conductive. However, the polymer becomes conductive after it is oxidized (pi-doped). This is because oxidation can accommodate positive charge spots over several pyrrole units on the Ppy chain compensating with anions from dopants. There are two types of conductive form, *polaron* and *bipolarons* shown in **Fig.5-5**. Generally, the polymerization and pi-doping occurs at the same time during electrolysis of pyrrole solution in the presence of dopants. Their conductivity varies over a range dependent on the conditions and dopants used in the process of oxidation.

Non-doped Ppy film is yellow but it becomes dark purple quickly in air due to oxidation. Doped films are blue or black depending on the degree of polymerization and film thickness.

2. Ppy preparation

Ppy is easily produced by polymerization of pyrrole through electrolysis and doped with various chemicals (dopants) in the laboratory. Several researchers have suggested simple procedures for producing conductive Ppy electrochemically by using several kinds of dopant compounds, both organic and inorganic, and have studied their electrical properties (Steet, 1983; Kang, 2000; RHEE, 1989; Kupila, 1993; Kakouis, 1992; Saville, 2005; Steven, 1993; Buting, 1997; Morales, 2000; Puanglek, 2012). In this study, we investigated the effect of anionic and neutral surfactants on the conductivity of Ppy synthesized by electrolysis, which had not been previously reported.

<Ppy with anionic surfactants>

Stainless steel plates of about 4.5× 15cm size and 0.5 mm thickness were used as electrodes for electrolysis. They were immersed in 100 mL of sample aqueous solution containing 0.05M of pyrrole and 1.0 g of a surfactant in a 200 mL beaker. Six types of surfactant dopants were used in the electrolysis to investigate six types of Ppy. The surfactants were; sodium dodecyl sulfate (SDS), sodium dodecylbenzenesulfonate (SBS), sodium naphthalene-2-sulfonate(SNS-2), disodium naphthalene-1,5-disulfonate (SNDS-1,5), sodium laurate (SL) and daily soap. Each electrolysis was carried out with 4.5V DC power supply for 10 min. After electrolysis, the electrodes with the deposited Ppy films were washed in distilled water and dried with tissue paper.

<Ppy with various ratios of anionic and neutral surfactants>

Aqueous 0.05M pyrrole solutions were prepared in the presence of anionic and neutral surfactant electrolyte. Anionic and neutral surfactant were dissolved in the electrolyte solutions in the ratios 4:0, 3:1, 2:2 and 1:3 by decreasing anionic surfactant concentration starting from 0.04 M to 0.01 M respectively and increasing neutral surfactant concentration (Table 1a, 1b, and 1c). Therefore, the amount of surfactant in the sample solutions was a constant 0.04 M. Four types of surfactants were used in the study, two of which were anionic and another two that were neutral, to study how surfactant concentration affected the electrical properties of Ppy. The two anionic surfactants were sodium dodecylbenzenesulfonate (SBS), sodium naphthalene-2-sulfonate(SNS-2), and the two neutral surfactants were polyoxyethylene (8) octyl phenyl ether (POE(8)OPE) and polyoxyethylene (30) docosyl ether (POE(30)DoE. **Table 5-1** shows the ratio of anionic surfactants and neutral surfactants applied in the study. Each solution was electrolyzed with 3.0 V DC power supply for 30 minutes. The electrodes with deposited Ppy were washed in distilled water and

dried with tissue paper. The molecular structures of the examined surfactants is shown in **Fig. 5-6**, whereas the Oxidative Ppy associated with anions of surfactant is shown in **Fig. 5-7**.

Table 5-1. Ratios of anionic and neutral surfactants in each 0.05M pyrrole solution

(a) SBS & POE(8)OPE

	Sample1	Sample2	Sample3	Sample4
Pyrrole	0.05M	0.05M	0.05M	0.05M
SBS	0.04M	0.03M	0.02M	0.01M
POE(8)OPE	0	0.01M	0.02M	0.03M
Ratio of SBS:POE(8)OPE	4:0	3:1	2:2	1:3

(b) SNS & POE(8)OPE

	Sample5	Sample6	Sample7	Sample8
Pyrrole	0.05M	0.05M	0.05M	0.05M
SNS	0.04M	0.03M	0.02M	0.01M
POE(8)OPE	0	0.01M	0.02M	0.03M
Ratio of SNS:POE(8)OPE	4:0	3:1	2:2	1:3

(c) SNS & POE(30)DoE

	Sample9	Sample10	Sample11
Pyrrole	0.05M	0.05M	0.05M
SNS	0.03M	0.02M	0.01M
POE(30)DoE	0.01M	0.02M	0.03M
Ratio of SNS:POE(30)DoE	3:1	2:2	1:3

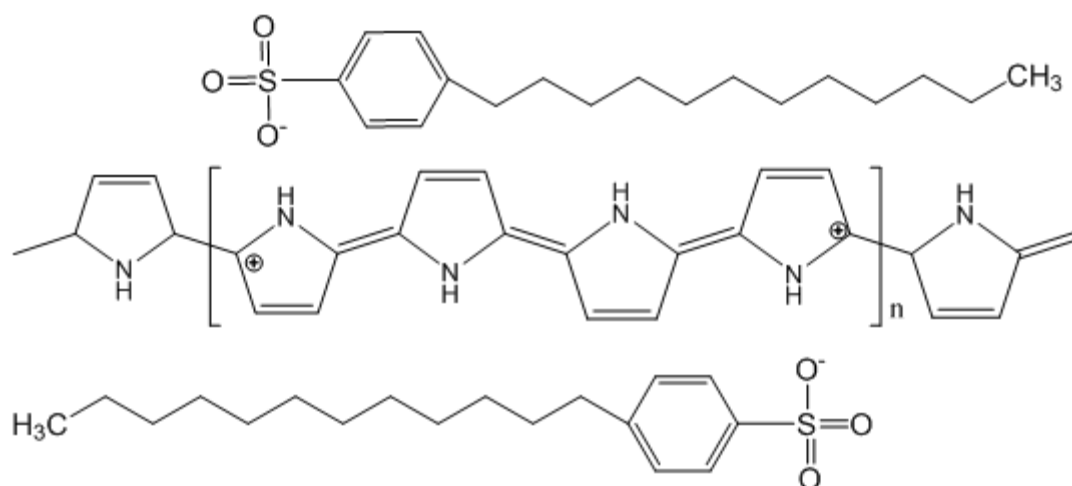

Fig.5-7. Oxidative Ppy associated with anions of surfactant, a conductive polymer.

3. Measurement of Ppy conductivity

The Ppy films were simply stripped off from the electrodes by applying and removing adhesive tape. The thickness of the tape was determined first, and then the thickness of the tape and the Ppy films measured with micro calipers. The Ppy film thickness was calculated by subtraction. Then the films were cut into 1.00×1.00 cm squares. Finally, the conductivity of Ppy films was determined by inserting the square-cut sample below the four-wire probe of the four-point probe chip in the handmade device, which was then connected to the 1.5V DC power supply, voltmeter and ammeter (digital multimeters) as shown in **Fig. 5-4**. The chip at the high end was pushed down with a finger to allow the four-wire probes to make good contact across the Ppy film. The current and voltage were recorded from the digital multimeters. The film resistances were calculated from Ohm's Law and the conductivity value of each Ppy film was calculated from equation (3).

V. RESULTS AND DISCUSSION

1. Standardization of the results

The data obtained from the experiments were standardized with the conventional four-point probe technique in order to prove that the handmade device provided reliable data

(Table 5-2). In this case, the conductivity values obtained from the conventional four-point probe technique were plotted against the inverse values obtained from the handmade device as shown in Fig. 5-8. The slope of the graph was 1.073 and $R^2=0.999$ meaning that the two measurement techniques gave almost the same values. This indicates that the handmade device can be appropriately used in the study to measure the conductivity of the semiconductor film.

Table 5-2: Standardized data table comparing the handmade and conventional four-point probe technique

	Conductivity values of Ppy with...			
	SNS 0.04M	SBS 0.03M : POE(8)OPE 0.01M	SBS 0.02M : POE(8)OPE 0.02M	SNS 0.01M : POE(30)DoE 0.03M
Conventional (S/cm)	41.15	0.7746	0.2991	4.6230
Handmade (S/cm)	44.25	0.7974	0.3041	5.2938

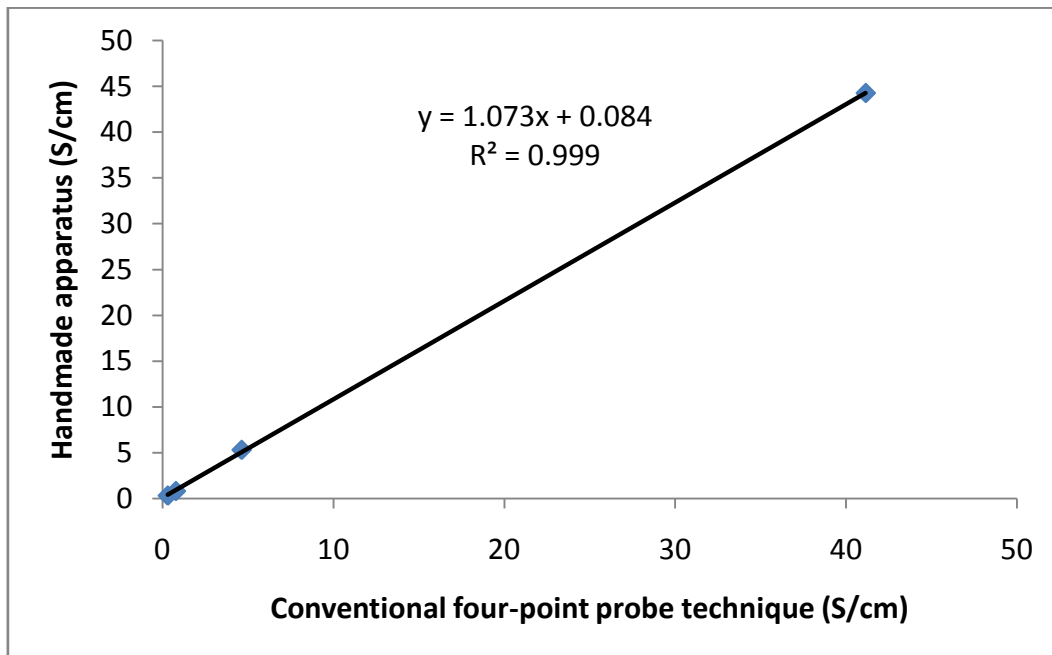

Fig. 5-8. Standardized data graph between handmade and conventional four-point probe technique

2. Ppy with anionic surfactants

The experimental results are shown in **Table 5-3**. They clearly revealed that each surfactant contributed a different conductive ability to polypyrrole. Among the surfactants used in doping during electropolymerization, carboxylate surfactants, sodium laurate and soap, were not good dopants as they could not produce Ppy films within a reasonable time period, whereas the surfactants whose molecules contained sulfonate groups (detergents), contributed well to the deposition of Ppy films on the cathode. The surfactant molecules formed monomer pyrrole micelles in the solution mixture of pyrrole and surfactant with their tails surrounding the pyrrole molecules, before the polymerization (Street, 1983). The ions from the surfactants allowed the solution to be electrolyzed. This phenomenon could help contribute to electropolymerization and the formation the Ppy film on the electrode.

Table 5-3. Conductivity of Ppy by different dopants (surfactants)

Ppy by Dopants	Voltage ($\times 10^{-3}V$)	Current ($\times 10^{-3}A$)	Resistance (Ω)	Thickness (cm)	Conductivity (S/cm)
Ppy-SBS	11.3	2.865	3.94	0.001	25.35
Ppy-SNDS-1,5	13.3	2.382	5.58	0.0005	35.82
Ppy-SDS	14.7	3.186	4.61	0.001	21.67
Ppy-SNS-2	9.2	2.268	4.06	0.0005	49.30
Ppy-SL	N/A	N/A	N/A	N/A	N/A
Ppy-Saop	N/A	N/A	N/A	N/A	N/A

The results suggested that the sulfonate surfactants could dissolve in the solution and formed monomer pyrrole micelles well compared to carboxylate surfactants. Different conductivity was observed from one film to another, though the one which produced the best conductivity was formed in the presence of sodium naphthalene-2-sulfonate. Among all

surfactants investigated, sodium docecylsulfonate produced the most brittle polymer as the film was easily torn apart during the operation of the conductivity measurement. The results suggest that the interactions between different surfactant molecules and the Ppy chains may contribute to successful Ppy film development and the differences in conductivity.

3. Ppy with various ratios of anionic and neutral surfactants

The presence of the neutral surfactants caused remarkable effect on the electrical properties of Ppy film. As shown in **Fig. 5-9**, the conductivity of Ppy film decreased drastically with just a quarter of the neutral surfactant compared to the anionic surfactant present in the electrolyte solutions. However, the conductivity seemed to continue decreasing very slowly as the amount of the neutral surfactants increased. The two neutral surfactants used in the investigation had almost the same effect, though POE(8)OPE seemed to contribute a lesser conductivity than POE(30)DoE. Thus we can assume that the molecules of neutral surfactants were also adsorbed or combined into the Ppy films together with anionic surfactants. In this case, the neutral surfactants could play the role of insulator that prevents the Ppy film from conducting electrical current.

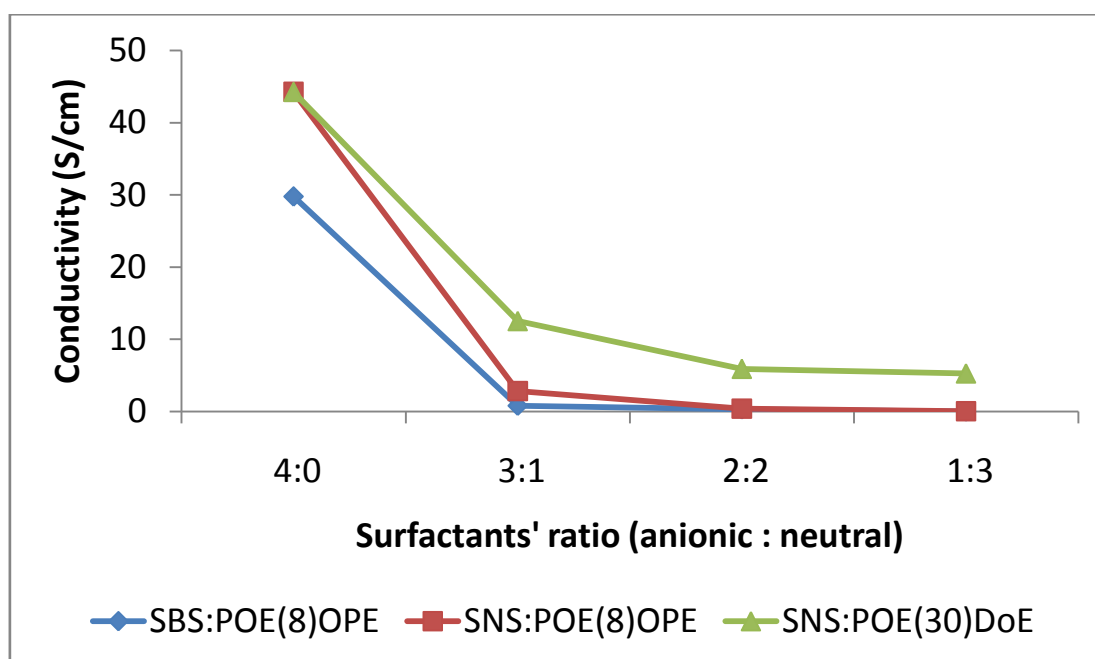

Fig.5-9. Conductivity of Ppy doped by anionic and neutral surfactants

Ppy has a range of properties caused by several factors such as how the cross-linking structures between polymer chains were formed and interspersed with the charged-balancing anions of surfactants, under what conditions polymerization was carried out such as electrolyte concentration, temperature, type of dopants, power supply, oxidation degree of the Ppy. etc. Chemical reaction mechanism, properties and fundamental applications of Ppy have also been discussed in detail in other publications (McNeill, 1963; Street, 1983; Kang, 2000; RHEE, 1989; Kupila, 1993; Kakouris, 1992; Saville, 2005; Steven, 1993; Buting, 1997, Morales, 2000; Puanglek, 2012; Leonavicius, 2011)

VI. APPLICATION TO CLASSROOM

1. Lesson Instruction

The lessons on Ppy and its conductivity were introduced to a high school class of 10 students in eleventh grade in Japan together with the developed handmade conductivity device. The concept taught to students was only the effect of anionic surfactants on the electrical property of Ppy. Three lab periods of 50 min were used. The students needed approximately 25 min to complete each experiment as a group, such as to synthesize the film samples and to examine the conductivity. In the first period, the instructor presented some basic knowledge about Ppy and its daily application. This included how Ppy is formed through electropolymerization, a brief chemical equation of polymerization, and a hint to examine and to calculate the conductivity value of a polymer film following the principle of the four-point probe method and deriving equation 3. During the second period, the students conducted electrolysis of pyrrole solutions in the presence of different types of anionic surfactant, such as SDS, SBS, SNS, SNDS, LS and soap, in order to produce different conductive polymers. Each group of students made two types of the above anionic surfactants. During the last period, the students examined the conductivity of the Ppy film they produced by using the handmade conductivity device and made comparisons. The students shared with

one another the films they produced amongst the groups. All groups of the students had opportunity to observe and to measure the conductivity of the six types of the films. All the sample solutions and materials were prepared for the students before the class periods. The students got similar results to those shown in **Table 5-3**.

2. Evaluation of the developed teaching and learning materials

<In General>

It was interesting that, in response to questions in the lesson introduction, all students replied with strong confidence that no plastic or polymer could conduct electricity. This was the most important part of the lesson and was intended to 'hook' the students' interest and motivate them towards a scientific and skilled investigation. During the investigation, the students were surprised that the Ppy polymer films were easily generated by electropolymerization and that they could conduct electricity. Beyond this, the students also observed that the Ppy films could be doped very well by some surfactants. The results showed that the surfactants containing the sulfonate group ($-\text{SO}_3^-$) in the molecule seemed to dope the Ppy films more easily than those containing the carboxylate group ($-\text{COO}^-$). During discussion the students understood that sulfonate surfactants might form micelles better than carboxylate surfactants by entrapping pyrrole molecules as monomers in the electrolyzed solution.

The students also found that among the conductive polymers, there was a variety of electrical conductivity. Through group discussion, the students found out which factors caused Ppy films to have different conductivity, such as type of surfactant, duration of electrolysis, distance between electrolyte electrodes, electrolyte concentration, power supply and so on. Therefore, the lessons provided students with an opportunity to study current science and technology about conductive plastics, which are being used commonly in daily life.

<Knowledge Improvement>

In general, the lessons could provide several scientific knowledge and skills to the students. As seen in **Fig. 5-10**, many students responded in the questionnaires to evaluate their own understanding that they understood the lesson concepts they learned from the lessons very well. This feedback was corresponding to their performance on the post test compared to that of pre-test, in which most of the students could achieve high scores (**Fig. 5-11**). Moreover, the students also commented that they learned a lot of knowledge and skills during the lesson as shown in **Fig. 5-12**.

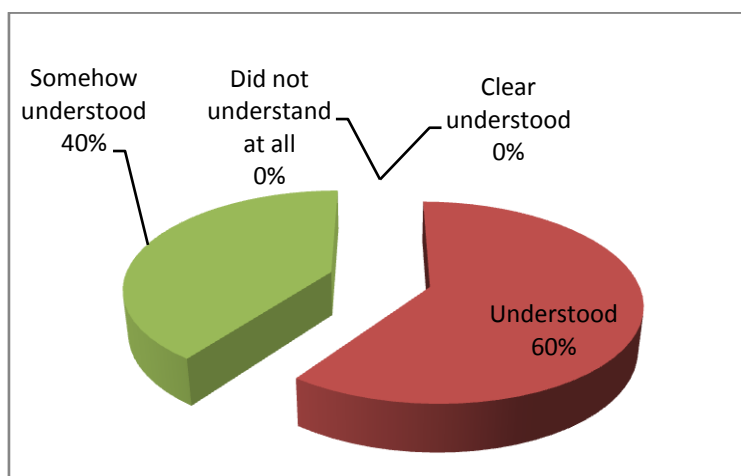

Fig. 5-10. Students evaluated their understanding on the lessons

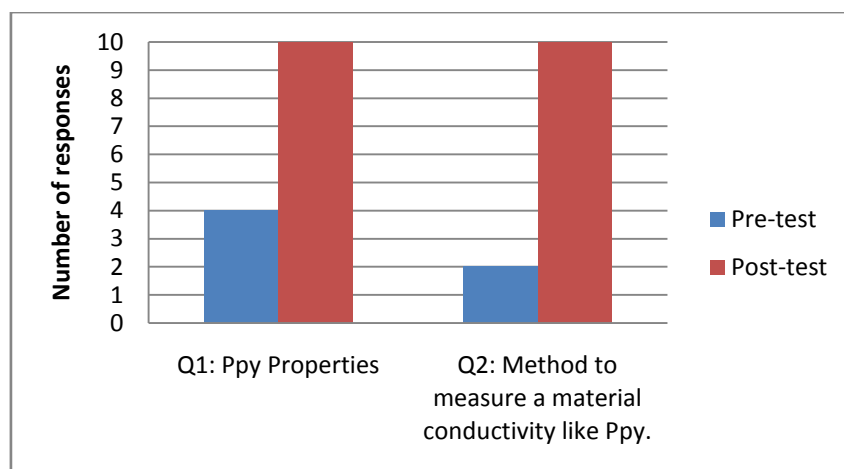

Fig. 5-11. Students' achievement on pre/post tests

Note: The detail questions on pre/post tests are attached in the APPENDIX

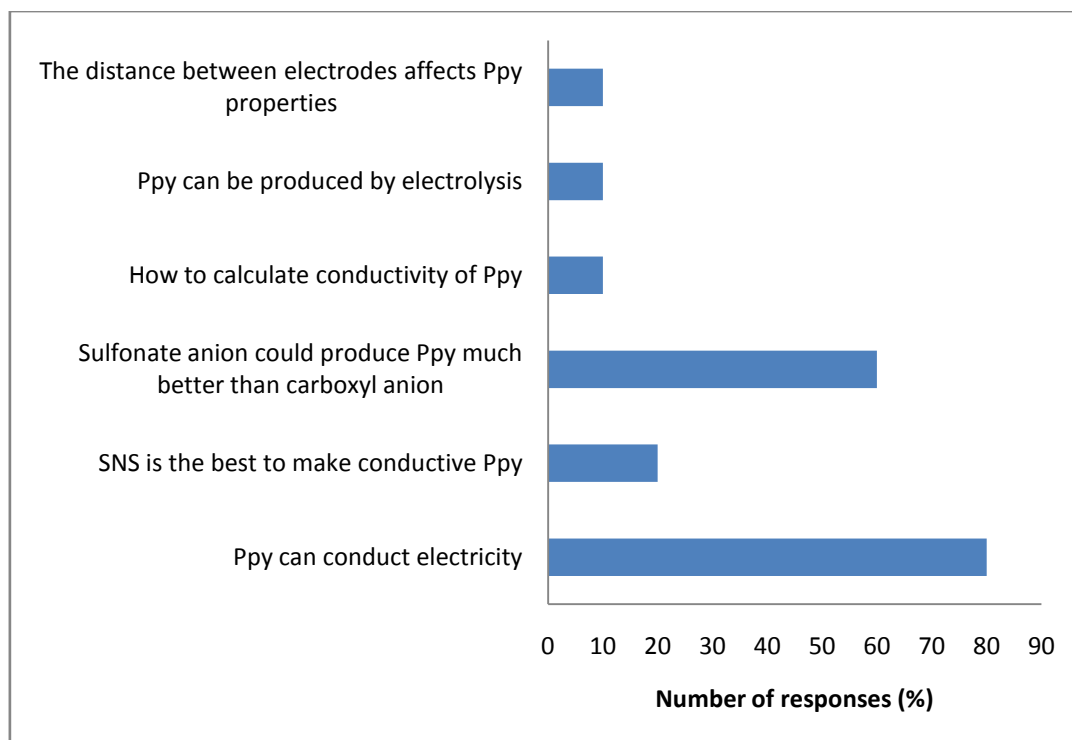

Fig. 5-12. Knowledge and skills students learned from the lessons

<Applicability>

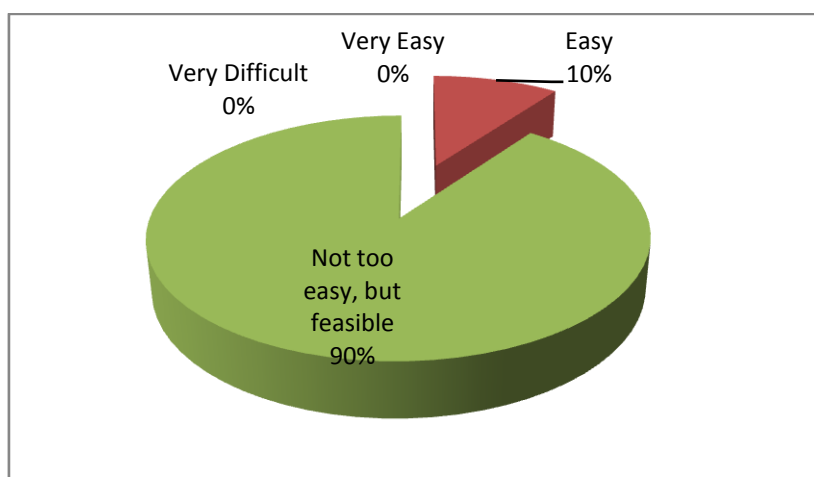

Fig. 5-13. Extent of applicability by using the hand-made apparatus

Most students could participate well with the lesson activities smoothly, as well as handle with the developed teaching and learning apparatus. They responded that although the developed materials seemed a bit difficult for them to understand its principle concept, they could operate to obtain the results from the experiments very well. As seen in

Fig. 5-13, most of them chose “Not too easy, but feasible” responding in the questionnaires. That means, the developed apparatus can be used properly by the students in the real classroom to investigate the conductive property of the semiconductor thin film such as pi.

<Students’ Satisfaction>

Although the lesson seemed a bit difficult to the students due to the contents on polypyrrole polymer was new to them, the students still showed high satisfaction on the lessons activities and the teaching materials were introduced in the lessons. As shown in the **Fig. 5-14**, many of them responded “Satisfied” and no one chose “Did not satisfied at all”. This result was also corresponded to the students’ interests in each lesson topic as shown in **Fig. 5-15**. Most them were surprised when the lessons showed that the plastic of polypyrrole they made could conduct electricity, which they have never realized before. Therefore, this lesson could hook the students’ interest effectively in further scientific investigation as a basic demand of science lessons.

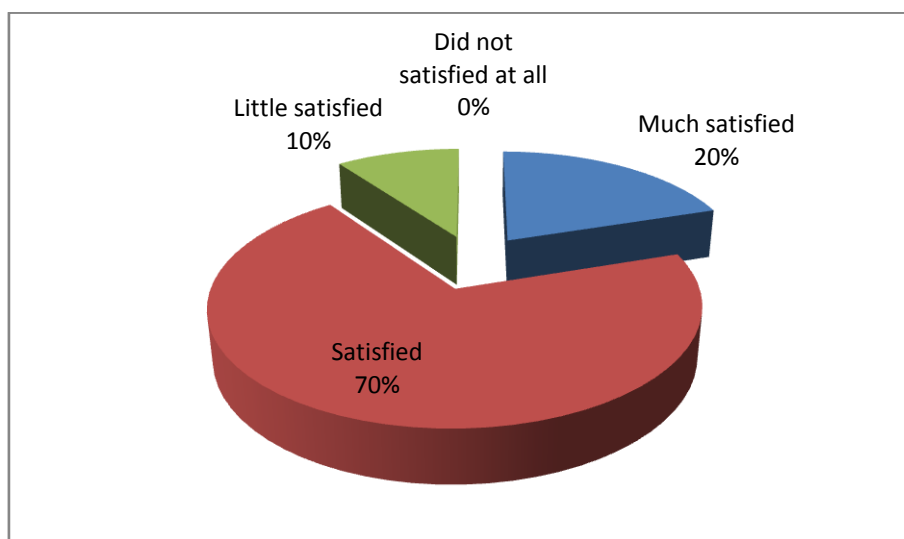

Fig. 5-14. Extent of students’ satisfaction on the lessons activities and teaching materials

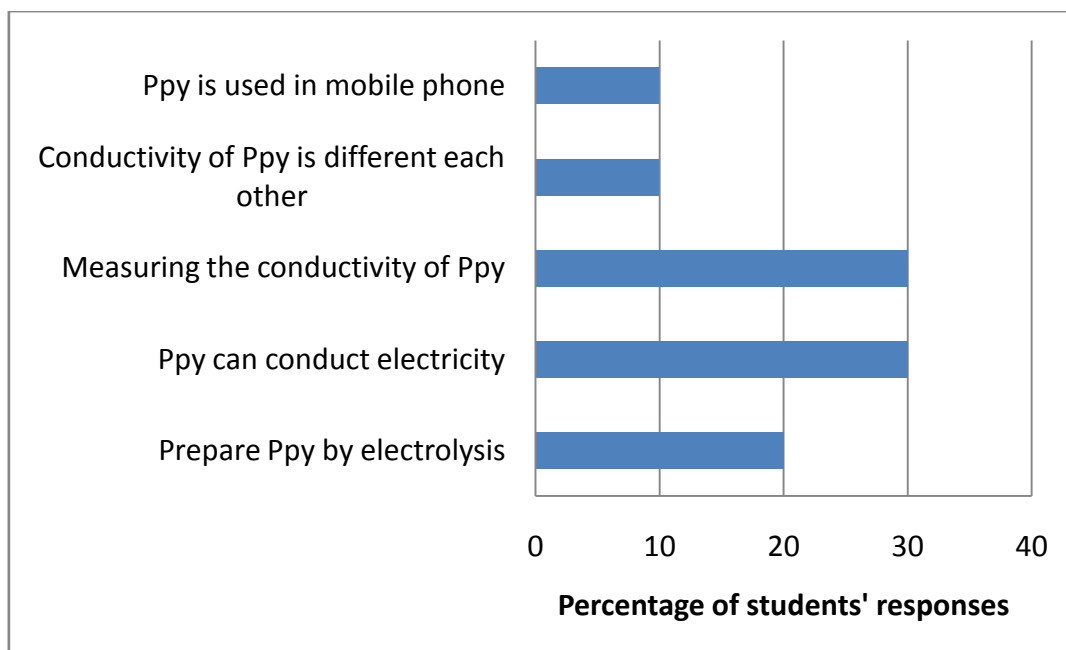

Fig.5-15. The interesting concepts/activities for students.

VII. CONCLUSION

The study revealed the effect of both anionic and neutral surfactants on the conductive properties of Ppy. The lessons on Ppy and its conductivity could help students understand the properties of conductive polymers, which rarely happen in real classrooms. Especially, by using the handmade device described here, students could measure and study the conductivity of the semiconductor such as Ppy films in which they synthesized by themselves in the classroom. On the other hand, this handmade device was easily assembled from inexpensive and available materials. The four-point probe chip that we developed was very simple, did not use silver or lead paste, and provided a trouble-free measuring technique and reliable values consistent with those obtained by conventional devices. Therefore, as an addition to other student-made instruments, this handmade device can be recommended for determining the electrical properties of semiconductors such as Ppy and it can be utilized as teaching and learning material at secondary level for both chemistry and physics.

REFERENCES

- Bunting, R. K.; Swarat, K.; Yan, D.; Finello, D. Synthesis and Characterization of a Conducting Polymer: An Electrochemical Experiment for General Chemistry. *J. Chem. Educ.*, **1997**, *74*(4), pp421-423
- Crayston, J. A.; Kakouris, C.; Walton, J. C. Poly(N-Hydroxypyrrole) and poly(3-phenyl-N-hydroxy-pyrrole): Synthesis, Conductivity, Spectral Properties and Oxidation., *Synthetic Metals.*, **1992**, *48*, pp 65-77
- Hasiah, S.; Ibrahim, K.; Seni, H. B.; Halim, K. B. K. Electrical conductivity of chlorophyll with polythiophene thin film on indium tin oxide as P-N Heterojunction solar cell. *J. Physical Sci.* **2008**, *19*(2), pp77-92
- The Nobel Prize in Chemistry 2000. http://www.nobelprize.org/nobel_prizes/chemistry/laureates/2000/ (Accessed date: Jul, 2014)
- Joo, W. L.; Francisco, S.; Jonatha, N.; Christine, E. S. Carboxylic Acid-Functionalized Conductive Polypyrrole as a Bioactive Platform for Cell Adhesion. *Biomacromolecules.*, **2006**, *7*, pp1692-1695
- Kang, H. C.; Geckeler, K. E. Enhanced electrical conductivity of polypyrrole prepared by chemical oxidative polymerization: effect of the preparation technique and polymer additive., *Polymer.*, **2000**, *41*(18), pp6931-6934
- Konkov, V. L.; Rubtsova, R. A. A theory for probe measurements of electrical conductivity of semiconductor films. *NASA.*, **1965**, pp135-141
- Kupila, E. L.; Kankare, J. Electropolymerization of Pyrrole – Effects of pH and Anions on the conductivity and Growth-Kinetics of Polypyrrole., *Synthetic Metals.*, **1993**, *55*(2-3), pp1402-1405
- Li, J. C.; Wang, Y.; Ba, D. C. Characterization of Semiconductor Surface Conductivity by using Microscopic Four-Point Probe Technique. *Physics Procedia.* **2012**, *32*, pp347-355

- Morales, J.; Olayo, M. G.; Cruz, G. J.; Castillo-Ortega, M. M.; Olyao, R. Electronic conductivity of pyrrole and aniline thin films polymerized by plasma. *J. Polymer. Sci.* **2000**, *38*, pp3247-3255
- Puanglek, N.; Sittattrakul, A.; Lerdwijitjarud, W. Enhancement of Electrical Conductivity of Polypyrrole and Its Derivative. *Sci. J. UBU.*, **2010**, *1(1)*, pp35-42
- Ramanaviciene, A.; Finkelsteinas, A.; Ramanavicius, A. Basic electrochemistry meets nanotechnology: Electrochemical preparation of artificial receptors based on a nanostructured conducting polymer, polypyrrole., *J. Chem. Educ.*, **2006**, *83*, pp.1212-1214
- Rhee, H.W; Jeon, E. J.; Kim, J. S.; Kim, C. Y. Doping characteristics of polypyrrole., *Synthetic Metals.*, **1989**, *28(1-2)*, ppC605-C610
- Saville, P. Polypyrrole: Formation and Use. *Defence Research and Development Canada (DRDC)- Atlantic.*, **2005**, pp1-33
- Steven, W. K.; Thomas, E. M. Experiments illustrating metal-insulator transitions in solid. *J. Chem. Educ.*, **1993**, *70*, pp855-860
- Street, G. B.; Clarkke, R. H.; Geiss, V. Y.; Nazzal, P.; Scott, J. C., Characterization of Polypyrrole., *J. de Phy.*, **1983**, *C3*, pp599-606

Chapter VI

**DEVELOPMENT OF TEACHING MATERIALS TO
EXAMINE VISCOSITY OF CARBOXYL METHYL
CELLULOSE**

I. INTRODUCTION

An important and fundamental physical property of fluids is viscosity, as it is physically expressed in transportation phenomenon such as momentum of flow. The Properties of solutions are commonly influenced by their static microscopic structures, however these structures are difficult to deduce from their dynamic properties.

Sodium Carboxyl methyl cellulose (CMC) is a polymer substance popularly used in food and cosmetics, as well as in the agricultural, chemical and biological engineering fields due to its relatively high viscosity in aqueous solution and environmentally friendly nature (Hollabaugh, 1945). Several researchers have investigated the properties of CMC and have published in this and other journals. Those studies have revealed the effectiveness of CMC as an additive, a substrate, a blending material, a stabilizer, a binder, a scaffold material, etc (Li, 2008; Su, 2010; Cheng, 2011; Sengupta, 2000; Li, 2007; Hicyilmaz, 2006; Tang, 2009). There have also been many reports on the viscosity of electrolyte solutions which have discussed the effects of concentration, temperature and pressure (Abdulagatov, 2007; Mao, 2009; Grimes, 1979; Kestin, 1981; Kestin, 1981; Zhang, 2007; Abbott, 2005). In general, the viscosity of solution is proportional to its concentration and pressure, but it is disproportional to temperature.

In this study, we investigated the effects of several metal ions with different sizes and charges on the viscosity of aqueous CMC solution. In previous publications of this journal, there have been several reports introduced simple methods for classroom application to examine the viscosity of liquid such as using a burette instead of Ostwald viscometer (Sorrell, 1971), construction of an automated timing device for an Ostwald setup (Urian, 1998), using an opto-mechanical mouse with the movement of a ball through the liquid by gravity (Mohammad, 2010), and so on. Adapting from the previous research, this paper introduces a dropping ball method with simple and inexpensive apparatus, which was confirmed by an

Ostwald viscometer. This paper also describes a classroom activity where the improvised apparatus was introduced to high school students in order to examine the effect of metal ions on viscosity of an aqueous CMC solution in a lesson on viscosity and intermolecular forces.

II. VISCOSITY

Viscosity is a physical property of fluids as it is physically expressed in transportation phenomenon such as momentum of flow. Dynamic properties are commonly influenced by the static microscopic structures in solutions so this property is commonly used to deduce the microscopic characteristics of matter such as particle size and shape as well as intermolecular interaction (force) in introductory chemistry courses. It is also very important for the design of engineering systems such as in chemical plants and the agricultural and food industries, where precise information about the viscosity of solutions is needed.

Viscosity of liquids is generally determined by the Poiseuille method in which the time for a given volume of liquid to flow by gravity through a capillary between two marks on an Ostwald viscometer is measured. The viscosity value is then calculated by the Poiseuille equation based on a standard liquid. Derivation of the equation for calculation of absolute viscosity is discussed in most physical chemistry textbooks. The expression of viscosity by the Poiseuille equation is as follows (Sorrel, 1971):

$$\eta = \frac{\pi p r^4}{8 \nu l} \times t \quad (1)$$

where η is viscosity, p is driving pressure of liquid, r is radius of capillary, ν is volume of liquid and l is distance between the two marks on the capillary.

By substituting the driving pressure of liquid, $p = \rho g h$, equation (1) can be rewritten:

$$\eta = \frac{\pi g h r^4}{8 \nu l} \times \rho t \quad (2)$$

where ρ is density of the liquid, g is acceleration of gravity and h is difference in height between the liquid levels.

For a given viscometer with a fixed capillary radius and a fixed volume of liquid for measuring the time of flow between two marks, equation (2) can then be simplified to:

$$\eta = A \times \rho t \quad (3)$$

where, $A = \frac{\pi g h r^4}{8 v l}$ is defined as an instrument constant.

With the same expression the equ.(3), the viscosity of a standard liquid at a certain temperature is:

$$\eta_0 = A \times \rho_0 t_0 \quad (3)$$

Finally, the viscosity of an unknown liquid can be determined as a relative value against that of a standard liquid, as follows:

$$\frac{\eta}{\eta_0} = \frac{\rho t}{\rho_0 t_0} \quad (4)$$

where $\eta_0/\text{mPa s}$, $\rho_0/\text{g cm}^{-3}$, t_0/s , $\eta/\text{mPa s}$, $\rho/\text{g cm}^{-3}$, t/s are viscosity, density and flow time of standard liquid (normally water) and aqueous sample, respectively. At a certain temperature, the standard values of viscosity (η_0) and density (ρ_0), normally water, are known from the literature and the densities of samples can be determined manually by several methods, such as the pycnometer method or densimeter.

III. CARBOXYL METHYL CELLULOSE

Carboxymethylcellulose (CMC) is a polymer substance popularly used in food and cosmetics as well as in the agricultural, chemical and biological engineering fields due to its relatively high viscosity in aqueous solution and environmentally friendly nature (Hollabaugh, 1945). It is a cellulose polymer derivative, normally in the form of a sodium salt (**Fig. 6-1**). Several researchers have investigated CMC properties. In agriculture research, CMC is used

as an additive to prepare controlled-release formulations of the herbicide acetochlor (Li, 2008) and to improve the structure and properties of soy protein isolate edible films (Su, 2010). In biology research, CMC is applied to increase the growth of bacterial cellulose (Cheng, 2011) and as substrate to determine the activity of enzymes through the reduction of sugar (Sengupta, 2000). In chemistry research, CMC can be used as an effective binder to enhance the stability of the Li-Si reactions resulting from the nature of Si-CMC chemical binding (Li 2007), as a stabilizer in the study of rheological characteristics of asphalt-water slurries including viscosity (Hicyilmaz, 2006), and as a scaffold materials to study the optical properties of phenylene ethynylene oligomers (Tang, 2009).

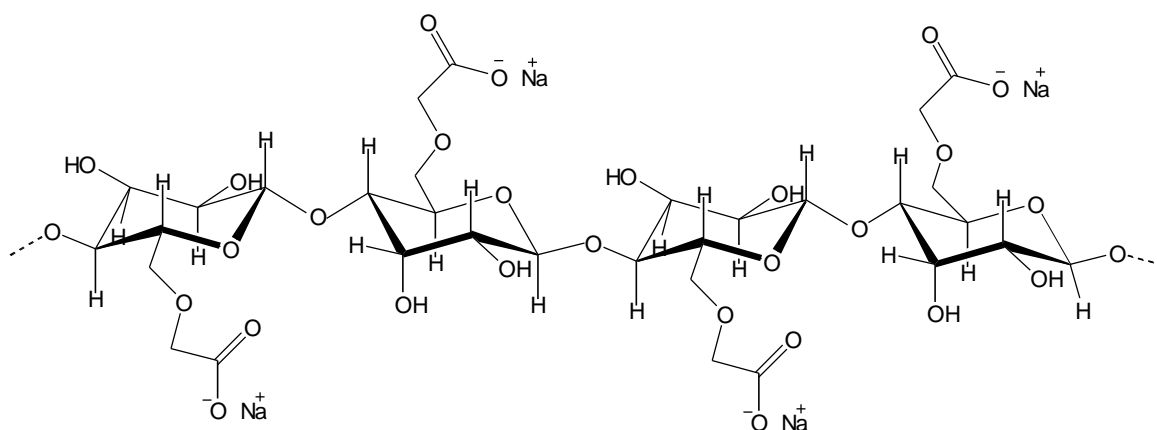

Fig. 6-1. Polymer structure of Carboxymethylcellulose (CMC) as sodium salt

IV. VISCOSITY DETERMINATION AND DEVELOPMENT OF APPARATUS

1. Sample Solution Preparation

The study used CMC as sodium salt with average molecular weight of ca. 90000 (purchased from ACROS ORGANICS). Three types of metal salts such as 1+ metal salts (LiCl, NaCl and KCl), 2+ metal salt (CaCl₂), and 3+ metal salts (AlCl₃ and [Co(NH₃)₆]Cl₃) were investigated their effect on the CMC viscosity. Each salt was dissolved in 0.50% w/v aqueous CMC solution separately to obtain metal ion concentrations in the range 0.00 – 0.10 mol kg⁻¹. The concentration of 0.50% w/v aqueous CMC solution is suitable for an Ostwald viscometer with 1.0 mm capillary diameter. Lower concentrations show only small changes

of viscosity with different metal ions, while higher concentrations have difficult flowing through the Ostwald capillary as they are too viscous. In this study, concentrations of 0.0021 mol kg⁻¹, 0.0042 mol kg⁻¹, 0.0083 mol kg⁻¹, 0.013 mol kg⁻¹, 0.017 mol kg⁻¹, 0.020 mol kg⁻¹, 0.033 mol kg⁻¹, 0.050 mol kg⁻¹, 0.067 mol kg⁻¹, 0.083 mol kg⁻¹ and 0.10 mol kg⁻¹ of each metal ion respectively, were prepared in the 0.50%w/v aqueous CMC solution.

2. By Ostwald viscometer

The precise viscosity value of each sample was obtained by using an Ostwald viscometer (capillary diameter = 1.0 mm) relative to the standard value of distilled water as solvent. A 10 mL sample was placed into the viscometer, immersed in a water bath at 25°C ($\pm 0.01^\circ\text{C}$) and kept for 2 min to stabilize the temperature. The sample was drawn by suction into the smaller reservoir of the viscometer and then allowed to flow by gravity. The flow time of the sample along the capillary from the upper to the lower mark on the viscometer was recorded. Five repetitions were measured for each sample (maximum deviation from the mean was ± 0.10 sec) and an average was obtained. The viscometer was washed between samples with a portion of the next sample to be measured. The viscosities of the sample were then calculated according to the equ. (4). The standard values of viscosity (η_0) and density (ρ_0) for water at 25°C were taken from the literature (Weast, 1988-1989), while the densities of samples were measured by the pycnometer method.

3. Development of dropping method apparatus

Although the Ostwald viscometer is a popular apparatus for the accurate determination of viscosity of liquids, it is expensive and is not suitable for classroom application. The operating procedures for using an Ostwald viscometer may be troublesome and time consuming for high school students. The glassware used is moderately expensive,

not always available in schools and is easily broken if students handle it without care. Therefore, in order to teach the concept of viscosity in a high school context, this research developed a dropping ball method using simple, inexpensive materials.

In the procedures developed, a transparent plastic tube having 2 cm inner-diameter and 1 meter length was installed vertically on a stand with the bottom end of the tube closed by a rubber stopper (Fig. 6-2). The tube was marked with two lines 500 mm apart. Plastic balls from a toy gun were used as dropping balls. The dropping balls were slightly different from one another in terms of weight, but their size was the same. Therefore, in order to reduce errors occurring from buoyancy on the dropping speed of the balls, only balls with the same weight (0.112g) were selected. The density of the balls was 1.020 g cm^{-3} , calculated from the average volume (0.110 mL) of

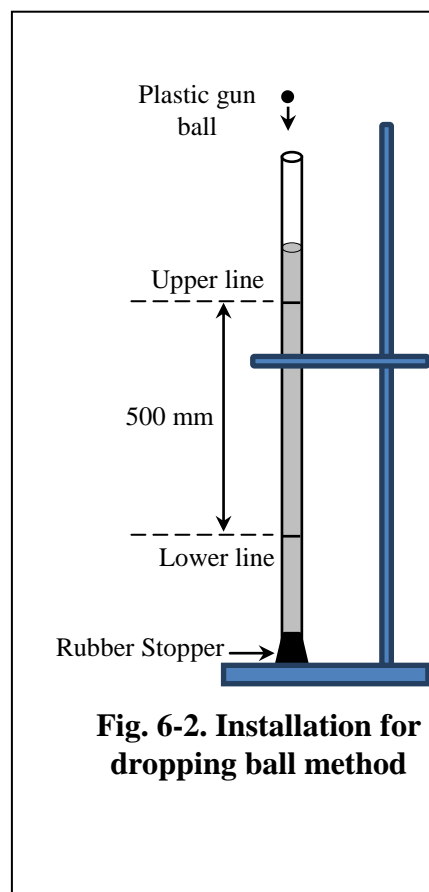

ten balls immersed in water in a 10 mL measuring cylinder. 250 mL of the sample solution was placed into the tube at room temperature and kept for a minute to allow the solution to stabilize. A ball was then dropped into the solution at the top of the tube. The time for the ball to fall from the upper to the lower line on the tube by gravity was recorded. Five replicate measurements were collected with each ball, and the three middle measurements were chosen for calculation of the average time. The maximum deviation from the mean was less than ± 1 sec. Finally, the speed of the dropping ball in each sample was obtained. We conducted all measurements at room temperature (ca. 25°C). The same number of measurements was carried out with the Ostwald viscometer at 25°C as mentioned above and used for calibration.

V. RESULTS AND DISCUSSION

1. By Ostwald viscometer

Fig. 6-3 shows that metal ions have significant effects on the viscosity of aqueous 0.50%w/v CMC solutions and its extent is particularly dependent on metal ion charges. The effects of 1+metal ions such as Li^+ , Na^+ , and K^+ on viscosity are all very similar. The viscosity of the aqueous CMC solutions is gradually decreased with the increase of alkali metal chloride concentration. On the other hand, the effect of 2+ metal ions is more dramatic. The CMC viscosity is decreased much more quickly with the increase of CaCl_2 concentration. However, in the case of 3+ cations such as Al^{3+} and $[\text{Co}(\text{NH}_3)_6]^{3+}$, the rapid formation of precipitates with the CMC anion occur as white ($[\text{Al}_m(\text{CMC})_n]$) and orange $\{[\text{Co}(\text{NH}_3)_6]_p(\text{CMC})_q\}$. Therefore, the results for 3+ cations are not shown in **Fig. 6-3**.

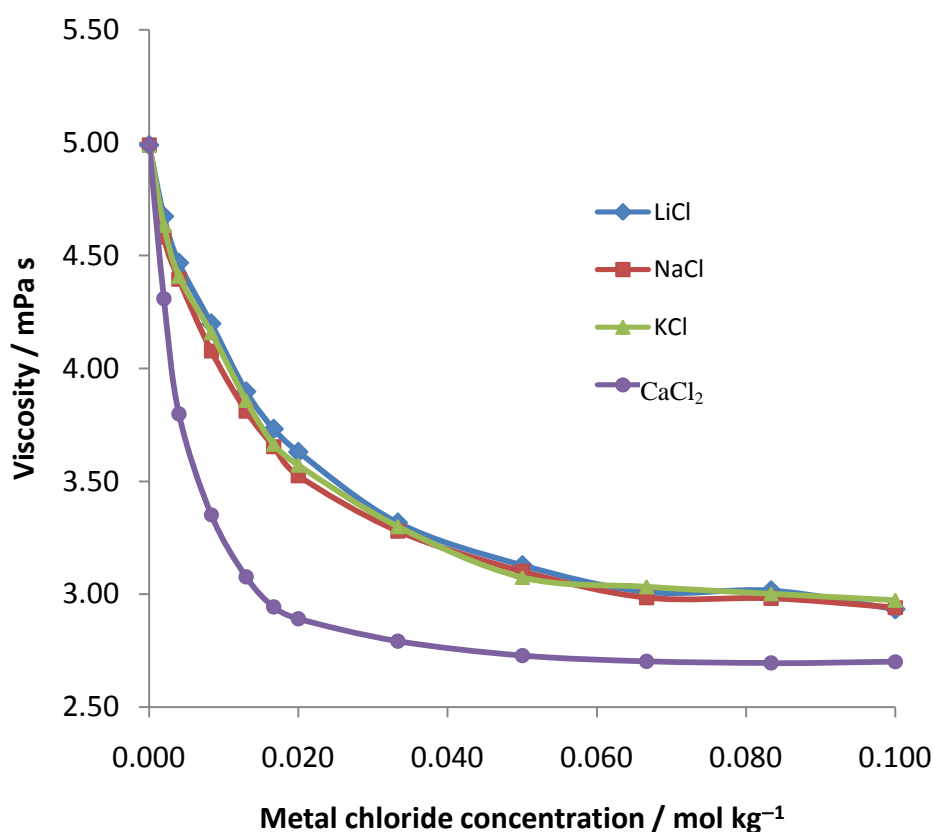

Fig. 6-3. Effects of metal ions on viscosity of aqueous 0.50%w/v CMC solution at 25°C

The solutions of CMC with 1+ metal ions also show similar Tyndall phenomena more clearly than that of CMC alone. Furthermore, this phenomenon became even more pronounced with 2+ metal ion (Ca^{2+}) as shown in **Fig. 6-4**.

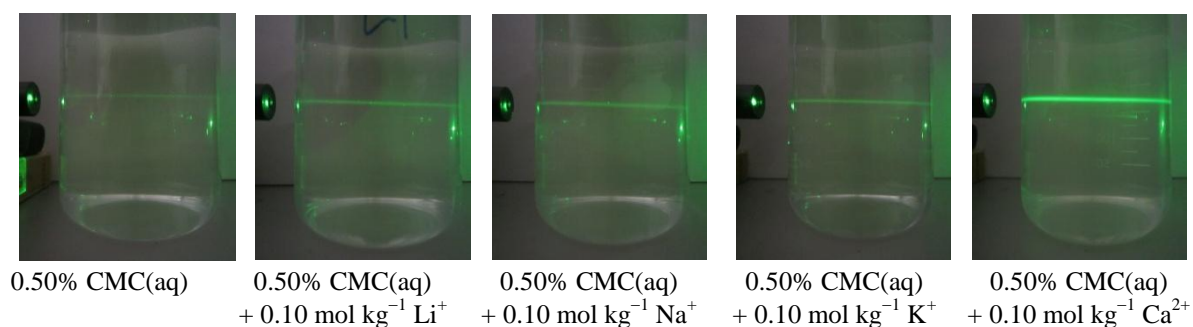

Fig. 6-4. Tyndall Effect of the sample solutions irradiated with 532 nm laser pointer

The Tyndall beam thickness suggests that the size of CMC aggregates increased as follows: $0.50\% \text{CMC}(\text{aq}) < 0.50\% \text{CMC}(\text{aq}) + 0.10 \text{ mol kg}^{-1} \text{M}^+ < 0.50\% \text{CMC}(\text{aq}) + 0.10 \text{ mol kg}^{-1} \text{Ca}^{2+}$. The viscosity decreased according to: $0.50\% \text{CMC}(\text{aq}) > 0.50\% \text{CMC}(\text{aq}) + 0.10 \text{ mol kg}^{-1} \text{M}^+ > 0.50\% \text{CMC}(\text{aq}) + 0.10 \text{ mol kg}^{-1} \text{Ca}^{2+}$ as shown in Figure 4.

In $0.50\% \text{CMC}(\text{aq})$ without the addition of metal chloride salt, CMC anions are dispersed because of electrostatic repulsion. So, the aqueous CMC solution shows a relatively high viscosity caused by the dispersed long CMC polymer chains. The addition of the excess metal cations into the CMC solutions can cause aggregation between CMC anions and metal ions due to cancellation of the electrostatic repulsion. This aggregation phenomenon reduces the number of free CMC anions and reduces the viscosity. The Ca^{2+} cations attract more CMC molecules to form bigger colloidal particles, thus reducing the viscosity further and producing a stronger Tyndall effect (**Fig. 6-5**). The intermolecular forces involve in this system include Hydrogen bonding among CMC molecules and electrostatic interaction (among CMC molecules and metal cations) in aqueous solution (Yang, 2007).

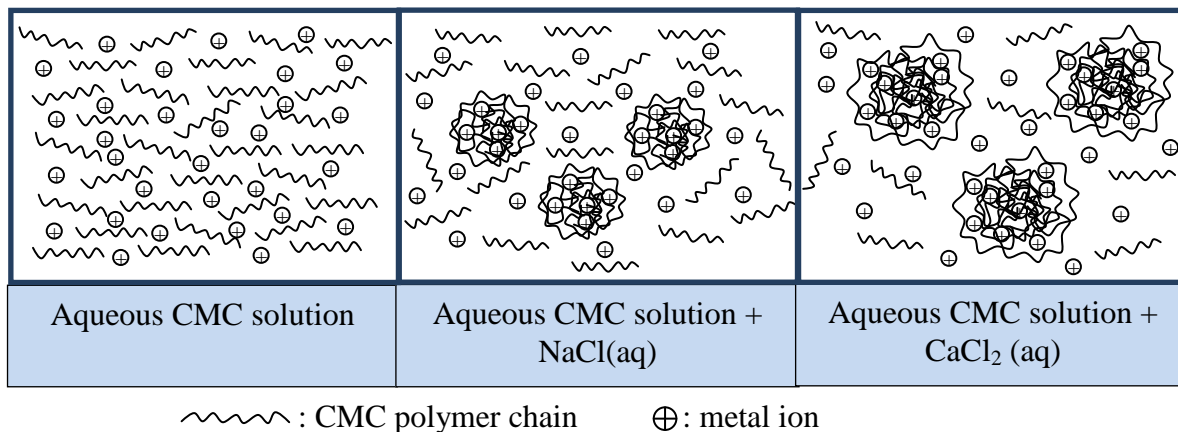

Fig. 6-5. Assumption of interactions between CMC polymer molecules and metal ions

2. Dropping ball method

The dropping speed of the plastic gun balls through the sample solutions along the vertical tube were plotted against the metal ion concentration together with the viscosities obtained by the Ostwald viscometer. Significantly, the results reveal that the dropping ball method is only valid with samples containing small concentrations of metal ions.

As seen in **Fig. 6-6**, the dropping speeds are increased almost proportionally with metal chloride concentration within a small range. The dropping speeds decrease dramatically when the metal chloride concentrations are increased over $0.050 \text{ mol kg}^{-1}$ for LiCl, $0.033 \text{ mol kg}^{-1}$ for NaCl and KCl, and $0.017 \text{ mol kg}^{-1}$ for CaCl₂, while the viscosities of solutions are almost same from these concentrations.

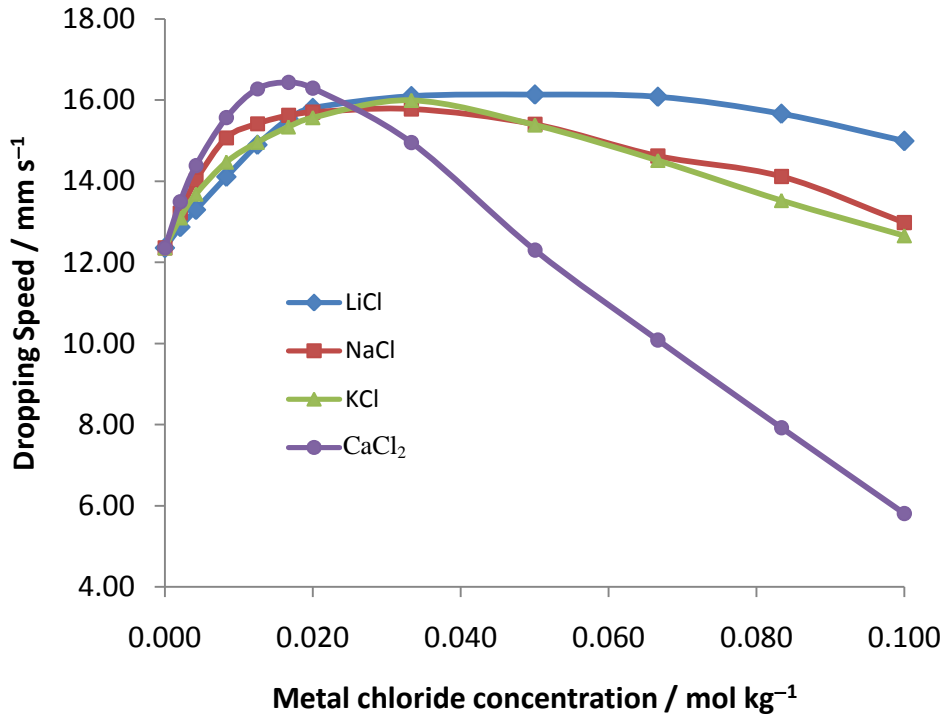

Fig. 6-6. Effects of metal ions on dropping speed in 0.50%w/v CMC(aq) at room temperature about 25 °C

Similar results are shown in **Fig 6-7**. The dropping speeds are varied almost inversely as the solution viscosity increases within those certain metal concentrations only. This is due to the buoyancy effect on the ball dropping speed, caused by the increase of the sample density resulting from the addition of metal chloride.

Therefore, using the dropping method to estimate viscosity of the sample solutions in this research seems to be only applicable for CMC solutions containing metal ions or metal chloride salts at small concentration. Another limitation of the dropping ball method is the difficulty of measurement at temperatures other than room temperature. One suggestion for improvement of this improvised apparatus is the use of a denser ball instead of a plastic ball ($d=1.020$) to measure viscosity at higher metal ion concentrations.

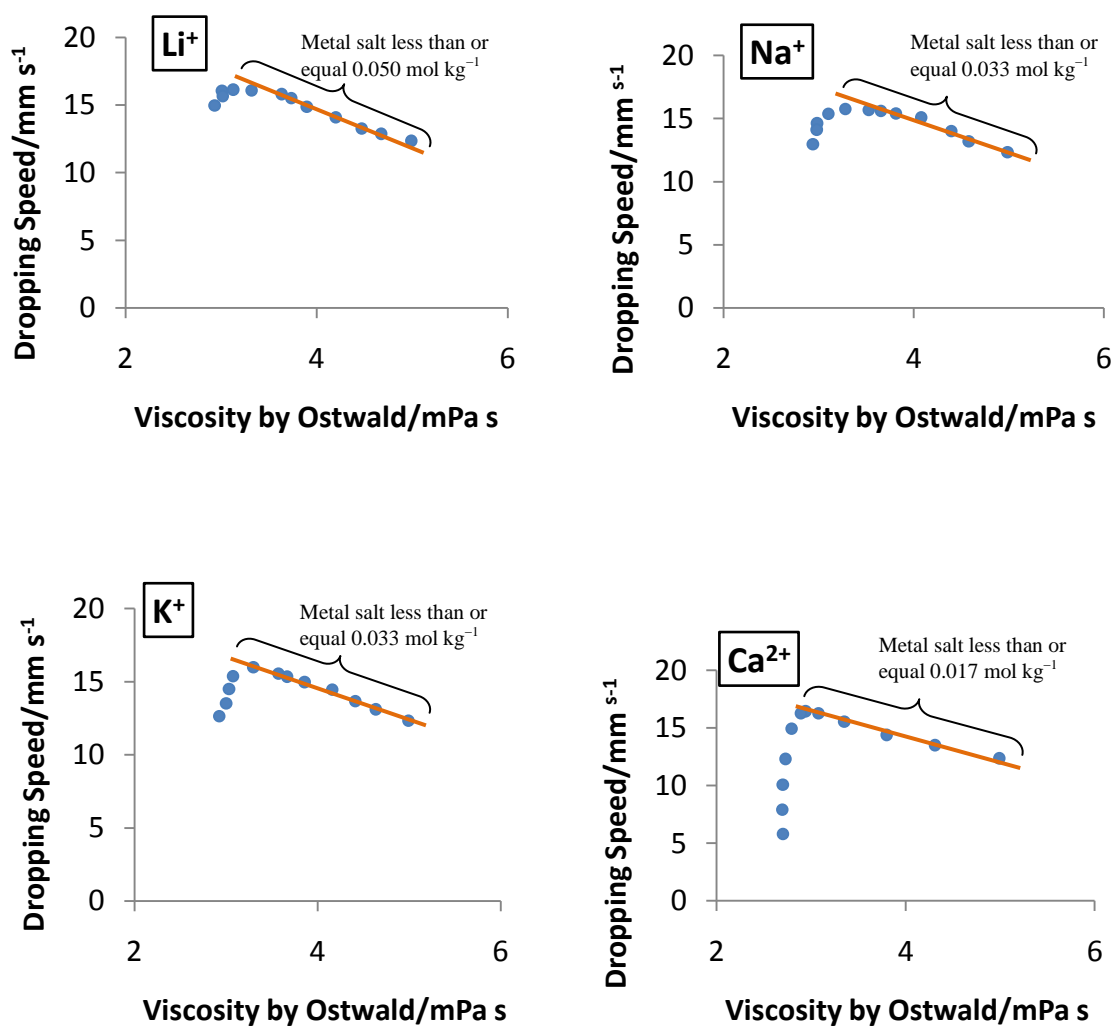

Fig. 6-7. Relationship of dropping speed with viscosity at 25°C

VI. APPLICATION TO CLASSROOM

1. Lesson Instruction

Same as the developed handmade device to measure the conductivity of the thin film semiconductor, the developed dropping apparatus was introduced to a high school class with 30 students at tenth grade in Japan through lessons on viscosity and intermolecular interaction based on the findings of this research. In the lessons, the students investigated and compared the different viscosities of distilled water, 0.50% NaCl(aq), 0.50% CMC(aq),

0.017mol kg^{-1} NaCl(aq) in 0.50% CMC(aq) and 0.017mol kg^{-1} CaCl₂(aq) in 0.50% CMC(aq).

Two lab periods of 50 min were used to complete all of the activities. The students needed approximately 25 min to conduct experiments as a group in each period.

In the first period after 5 min pre-lesson assessment, the instructor helped students to explore some basic concept about viscosity of liquids and its daily application. Several questions were asked to engage the students such as, “What does viscosity mean?”, and “How do metal ions affect viscosity of CMC solution?”, etc. By following the worksheet, the students were asked to formulate an hypothesis and then investigate how viscosity differed between water, 0.50% NaCl(aq) and 0.50% CMC(aq). In the second period, the students continued formulating their hypothesis and investigating the viscosity of 0.017mol kg^{-1} NaCl(aq) in 0.50% CMC(aq) and 0.017mol kg^{-1} CaCl₂(aq) in 0.50% CMC(aq). In the last 30 minutes, the students discussed as a group then drew a bar chart of the average dropping speeds of the plastic gun ball through each sample solution. The 0.50% CMC(aq) and materials were prepared for the students before the class periods, while adding the metal salts into water and 0.50% CMC(aq) to make the mixture samples were made by the students in the class. The students’ results from a representative group are shown in **Fig. 6-8**. At the end of the lessons, the students were able to discuss and explain the effects of metal ions on the viscosity of CMC(aq) by using the molecular or particle structure diagrams. Finally, the lesson contents were summarized and the Tyndall Effect briefly demonstrated by the instructor.

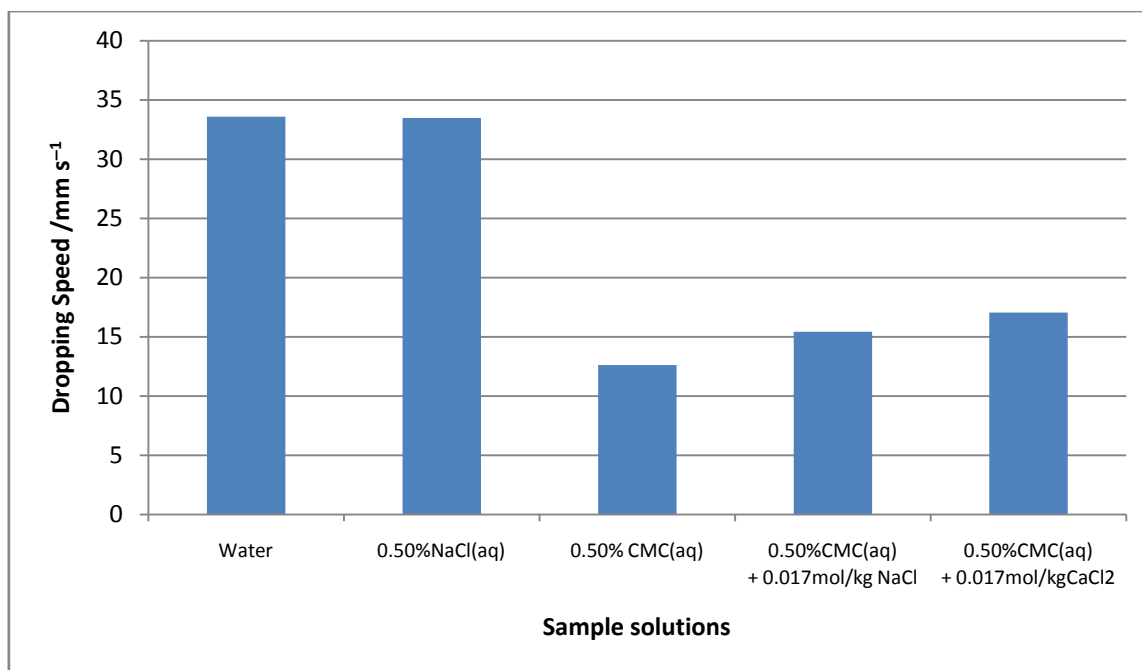

Fig. 6-8. Students' results on investigation of the sample solution viscosities by the dropping ball method

2. Evaluation of the developed Teaching and Learning Materials

<In general>

It was interesting that after introducing diagrams of molecular structures of CMC to be investigated, the students could effectively formulate their hypothesis on the worksheets and could hardly wait to conduct the experiments to confirm their hypothesis. During the investigation, the students were surprised that the presence of metal salts decreased the viscosity of aqueous CMC solution, because most of them thought that adding more substances into a solution would make the viscosity increase. The presence of the metal cations can screen the charges on the CMC, thereby causing the polymer chains to shrink corresponding to the decrease in viscosity. While the viscosity of water was confirmed to be similar to that of NaCl(aq), and CMC(aq) had the highest viscosity amongst the investigations based on the experimental results, the students also found out that CaCl₂ decreased the viscosity of CMC(aq) more than NaCl.

From the students' group discussion and after the final lesson summary by the instructor, the students could well understand that the aggregations of CMC molecules and metal ions could change the viscosity of a solution. Therefore, in addition to introducing sizes and shapes of particles, the lessons provided students with an opportunity to learn about intermolecular interaction, which is another factor that affects the viscosity of solutions. The intermolecular forces involved in this system include Hydrogen bonding among CMC molecules and electrostatic interaction (among CMC molecules and metal cations) in aqueous solution (Yang, 2007). At the end of the lesson, the students received additional explanation about the limitations of the dropping ball method caused by the buoyancy effect as discussed in Figure 2.

<Knowledge Improvement>

Same as other lesson, most students could understand the lesson concepts on viscosity of solution we taught. As shown in **Fig. 6-9**, most of the students responded "clearly understood" and "understood" in the questionnaires. This is also in accord with the pre/post test performed by the students as shown in **Fig. 6-10** that showed students' improvement before and after the lessons significantly. After the lesson, students could provide the correct answers to the test. They could explain that the interaction of particles in the solution could effectively and closely make changes in viscosity. In this lesson, the aggregation of colloidal particles could decrease the viscosity of CMC solution. The students also responded in the questionnaires that they could learn a lot of knowledge and skills from this lessons (**Fig.6-11**). Therefore, the lesson could improve the students' performance remarkably in content knowledge.

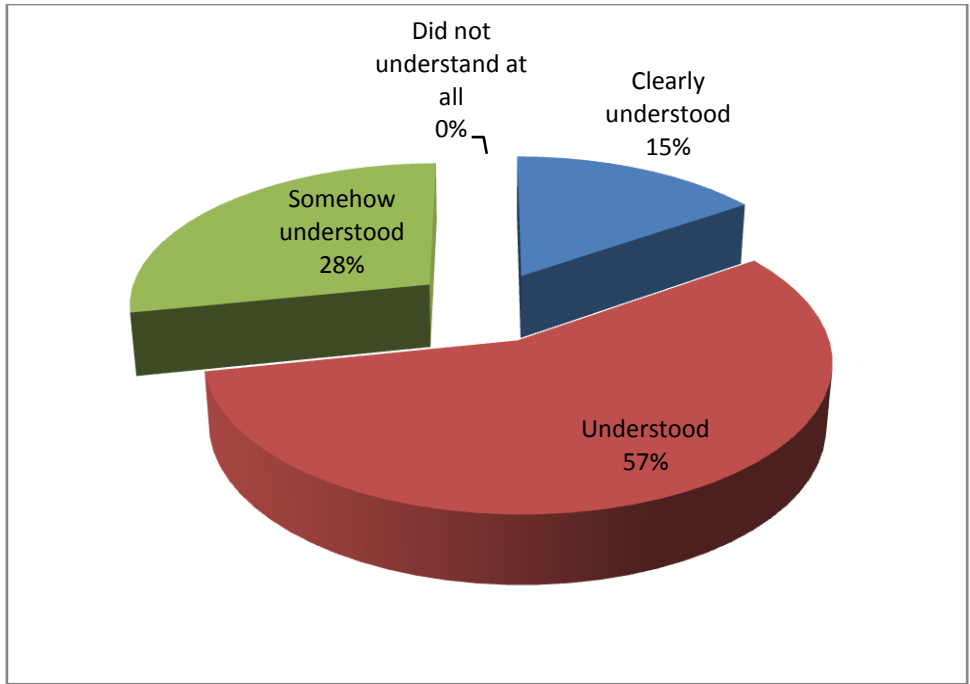

Fig. 6-9. Students evaluated their understanding of the lessons

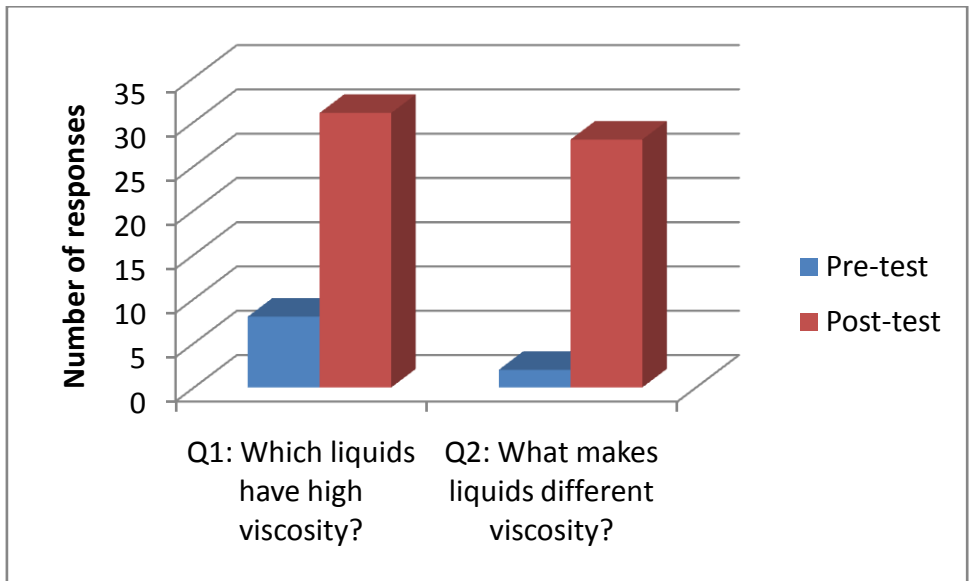

Fig. 6-10. Students' performance on pre/post tests

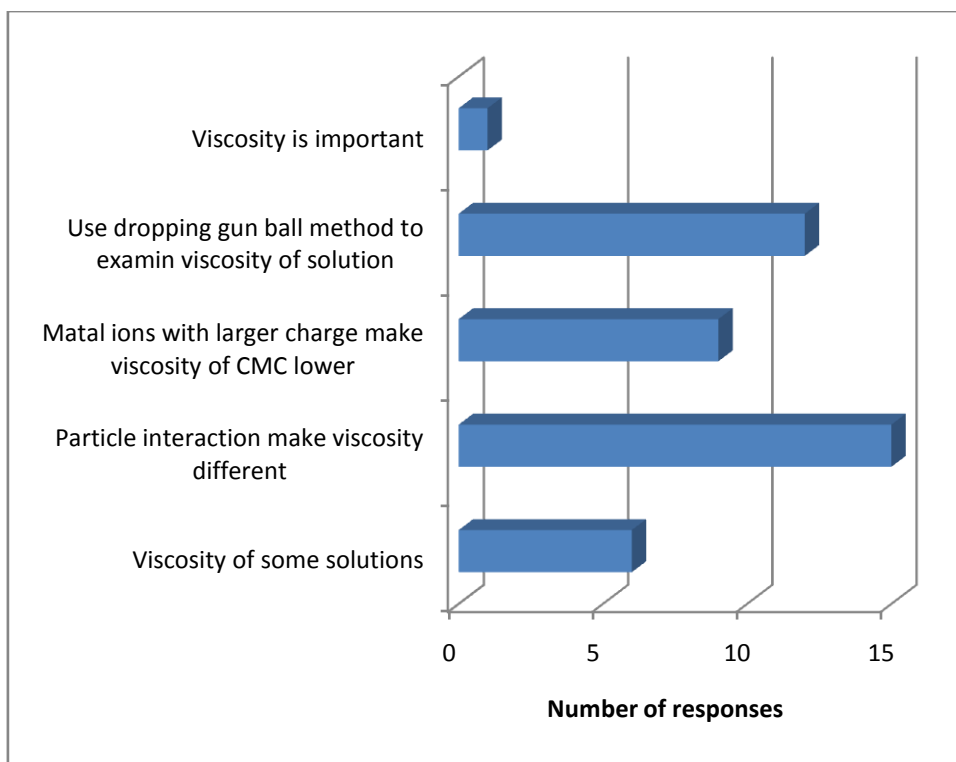

Fig. 6-11. Students claimed their knowledge and skills they learned

<Feasibility>

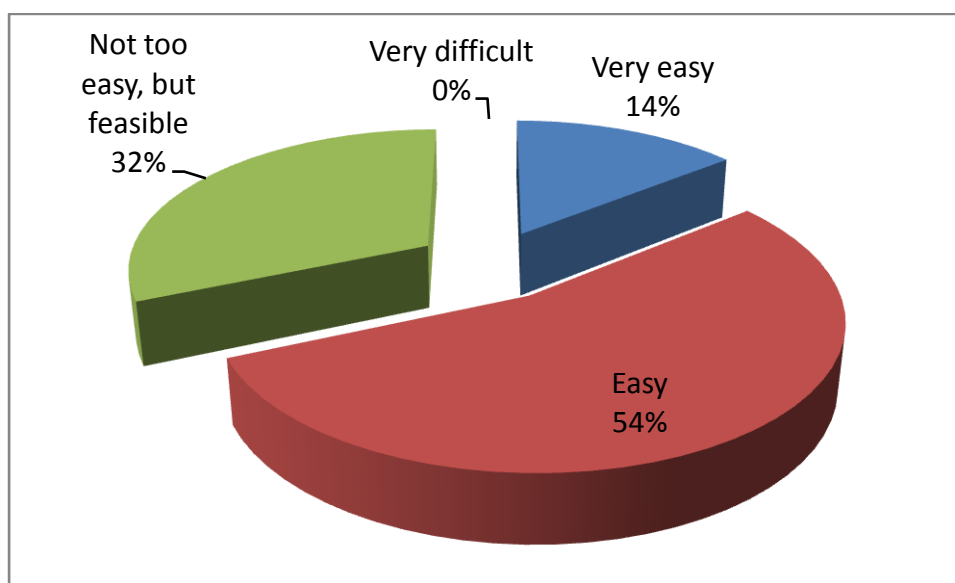

Fig. 6-12. Students' feasibility to operate the developed teaching and learning materials

The lessons and the developed teaching materials seemed to be feasible for students in the classroom application without difficulty. As shown in **Fig. 6-12**, the most of the students

said it was easy to operate. What they needed to do was just dropping a plastic ball gun into the sample solution and record the drop time. From the dropping speed, they could assume the sample solution viscosity.

<Satisfaction>

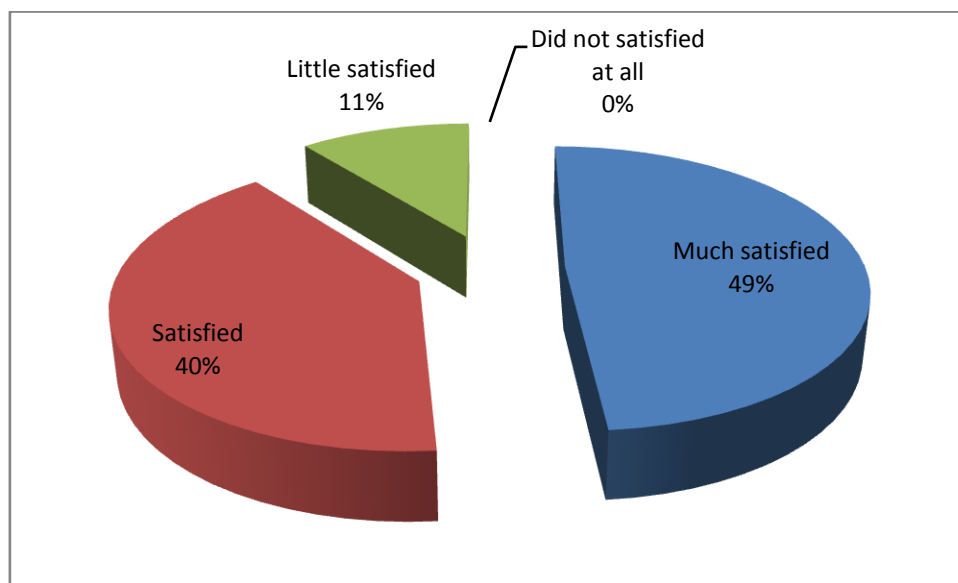

Fig. 6-13. Students’ satisfaction on the introduced activities and teaching and learning materials

Most of the students seemed satisfied with the lessons and the teaching and learning materials that were introduced to them. As shown in **Fig. 6-13**, most students responded “much satisfied” and “satisfied” in the questionnaires. At the same time, the students also showed the most interest topics for them during the lessons (**Fig. 6-14**). Most of them were surprised to see the viscosity of CMC decreased when some amount of salt was added. Therefore, the lesson could effectively hook students’ interest and encouraged them in further scientific observation.

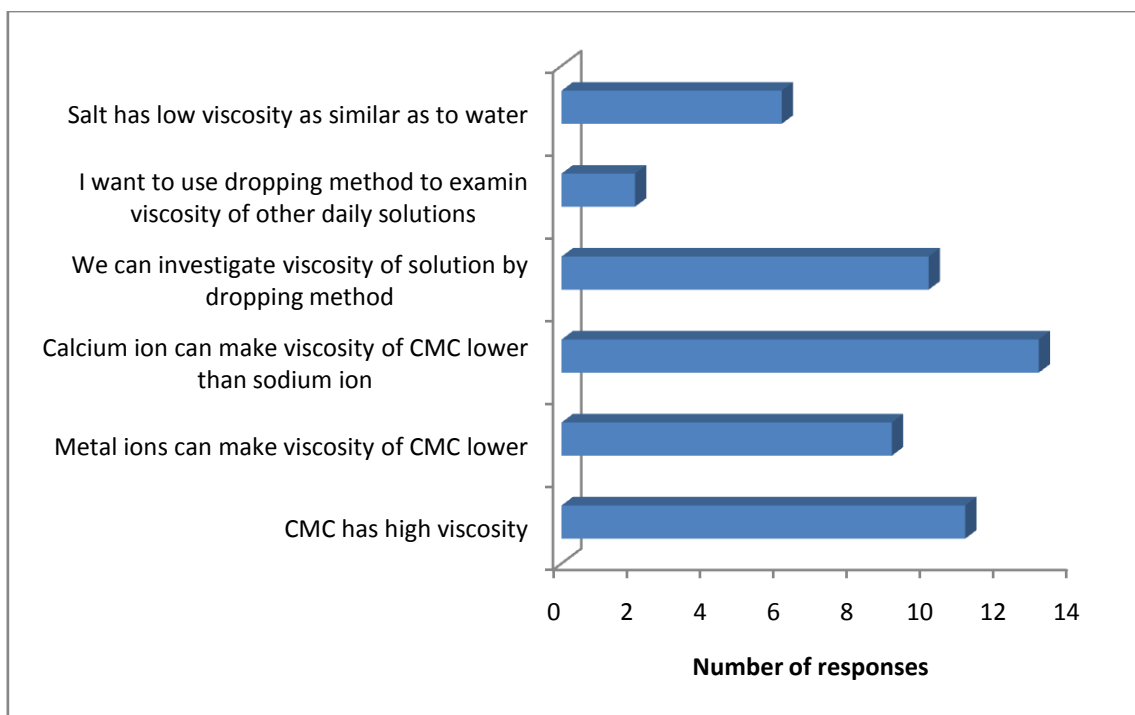

Fig. 6-14. The interest contents for students

VII. CONCLUSION

The study successfully developed the dropping ball method to examine the viscosity of some aqueous sample such as CMC solutions. The study also revealed that metal ions at very low concentrations could significantly decrease the viscosity of an aqueous CMC solution. Moreover, by introducing the dropping ball method with improvised apparatus in the classroom at secondary schools, the students could examine and compare the viscosities of solutions and discuss the intermolecular force in the aqueous CMC solution.

Although the dropping ball method has some limitations, like; consuming greater amounts of solution, temperature not easily controllable and providing only a relative not a real viscosity value, the associated ideas is valuable in the instruction of basic chemistry, especially in situations which lack experimental apparatus. Based on the students' performance in the lessons and their responses in the questionnaires, the introduced improvised apparatus can be appropriately recommended as teaching and learning material for high school chemistry classes for examining the viscosity of liquids or solutions.

REFERENCES

- Abbott, P. A.; Hope, G. E.; Palmer, J. D. Effect of Electrolyte Concentration on the Viscosity and Voltammetry of Supper-critical Solution. *Anal. Chem.* **2005**, *77*, pp 6702-6708.
- Abdulagatov, M. I.; Azizov, D. N. Experimental Study of the Effect of Temperature, Pressure, and Concentration on the Viscosity of Aqueous SrCl₂ Solutions in the Range of (293 to 474) K and (0.1 to 20) MPa. *J. Chem. Eng. Data.* **2007**, *52*, pp 841-850.
- Alkahasov, B. A.; Magomedov, B. U. Dynamic Viscosity of Aqueous Solutions of Salts at High Temperature and Pressures and Concentrations. *J. Eng. Phys. Thermophys.* **2007**, *80*(6), pp 1216-1222
- Cheng, C. K.; Catchmark, M. J.; Demirci, A. Effects of CMC Addition on bacterial cellulose production in a Biofilm Reactor and Its Paper Sheets Analysis. *Biomacromolecules.* **2011**, *12*, pp730-736.
- Grimes, E. C.; Kestin, J.; Khalifa, E. H. Viscosity of Aqueous KCl solutions in the Temperature Range 25-150 °C and the Pressure Range 0-30 MPa. *J. Che. Eng. Data.* **1979**, *24*, pp 121-126.
- Hicyilmaz, C.; Ozun, S.; Altun, E. N. Rheological Properties of Asphaltite-Water Slurries. *Energy & Fuels.* **2006**, *20*, pp 2037-2045.
- Hollabaugh, C.B; Burt, L. H; Walsh, A.P. Carboxymethylcellulose: Uses and Applications. *Ind. Eng. Chem.* **1945**, *37*(10), pp 943-947
- Kestin, J.; Khalif, E. H.; Correia, J. R. Table of The dynamic and Kinematic Viscosity of Aqueous KCl Solutions in the Temperature Range 25-150 °C and the Pressure Range 0.1-35 MPa. *J. Phys. Chem. Ref. Data.* **1981**, *10*(1), pp 57-70.
- Kestin, J.; Khalif, E. H.; Correia, J. R. Table of The dynamic and Kinematic Viscosity of Aqueous NaCl Solutions in the Temperature Range 25-150 °C and the Pressure Range 0.1-35 MPa. *J. Phys. Chem. Ref. Data.* **1981**, *10*(1), pp 71-87.

- Li, J.; Li, Y.; Dong, H. Controlled Release of Herbicide Acetochlor from Clay; Carboxymethylcellulose Gel Formulations. *J. Agric. Food Chem.* **2008**, *56*, pp 13336-1342.
- Li, J.; Lewis, R.B.; Dahn, J.R. Sodium Carboxymethyl Cellulose A Potential Binder for Si Negative Electrodes for Li-Ion Batteries. *Electrochem. Solid-State Lett.* **2007**, *10*(2), pp A17-A20
- Mao, S.; Duan, Z. The Viscosity of Aqueous Alkali-chloride Solutions up to 623K, 1,000 bar, and High Ionic Strength. *Int J Thermophys.* **2009**, *30*, pp 1510-1523.
- Mohammad, M. D.; Norooz, M.; Hojjatollah, K. A Low-Cost Viscometer from an Opto-mechanical Mouse. *J. Chem. Educ.* **2010**, *87*(12), pp 1411-1413
- Sengupta, S.; Jana, M. L.; Sengupta, D.; Naskar, A. K. A note on the estimation of microbial glycosidase activities by dinitrosalicylic acid reagent. *Appl. Microbiol. Biotechnol.* **2000**, *53*, pp 732-735.
- Sorrell, A. C. Liquid Viscosity Measurement Using a Buret. *J. Chem. Educ.* **1971**, *48*(4), pp 252-254.
- Su, F.J.; Huang, Z.; Yuan, Y.X.; Wang, Y.X.; Li, M. Structure and properties of carboxymethyl cellulose/soy protein isolate bland edible films cross linked by Maillard reactions. *Carbohydrate Polymer.* **2010**, *79*, pp 145-153.
- Tang, Y. L.; Zhou, Z. J.; Ogawa, K.; Lopez, G. P.; Schanze, K. S.; Whitten, D. G. Synthesis, Self-Assembly, and Photo-physical Behavior of Oligo Phenylene Ethylenes: From Molecular to Supra-molecular Properties. *Langmuir.* **2009**, *25*, pp 21-25.
- Urian, R.C.; Lutfur, R. K. A Diode-Laser Based Automated Timing Interface for Rapid Measurement of Liquid Viscosity. *J. Chem. Educ.* **1998**, *75*(9), p 1135
- Weast, C. B.; Astle, J. M.; Beyer, H. W. *CRC Handbook of Chemistry and Physics*, 69th ed.; RCR Press. Inc., Boca Roton, Florida, **1988-1989**, pp F-4 & F-40

Yang, X.H. & Zhu, W.L. Viscosity properties of sodium carboxymethylcellulose solutions.

Cellulose, **2007**, *14*(5), p.409-417

Zhang, L. H.; Chen, H. G.; Han, J. S. Viscosity and Density of H₂O + NaCl + CaCl₂ and H₂O

+ KCl + CaCl₂ at 298.15K. *J. Chem. Eng. Data*.**1997**, *42*, pp 526-530.

Chapter VII

CONCLUSION

The Thesis has described the study of Cambodian students' competency and development of several teaching materials for chemistry at the secondary school level. The study has examined the level understanding of Cambodian students at lower secondary school on Chemistry in both content domain and cognitive domain by using TIMSS 2011-standard test. The study has also described the development of several teaching and learning apparatus from simple and available materials and lesson activities for the chemistry classroom at secondary level in the topic areas of detergent, conductivity and viscosity (intermolecular force).

I. CAMBODIAN STUDENTS' COMPETENCY IN CHEMISTRY

Addressing to the research question 1 (To what extent do lower secondary school students in Cambodia understand the chemistry concept?), the study showed that although less than 50% of Cambodian students could perform the TIMSS standard test, this number is not bad if compared to the regional countries such as Thailand, Malaysia and Indonesia. Cambodian student's achievement was similar to those of Thailand, Malaysia and Indonesia, however, they were all still below the ASEAN and international averages and far below Japan all in the chemistry content domain and the science cognitive domain. Among the students participated in the test, many of them performed highly in memorizing, but less in reasoning and applying the chemistry concepts. The results also showed that there was not a significant difference in performance between Cambodian male and female students. Although, the students from the districts seemed to perform slightly better than those from the towns indicated by p-value of the T-test, their mean scores were very slightly different. Discussing by implying to the current science education context, the research also revealed several weak points which caused the Cambodian students have low performances in science education. Those are the chemistry contents in the current textbook are not yet meet the international benchmark, namely the content in the TIMSS standard test. Moreover, most of

the contents in the Cambodian textbook are more about the theory which encourage students to memorize, but less in encouraging students to discuss for scientific reasoning and applying to the real practice in the classroom or in daily life. The situation is also in accord with lack of teaching and learning materials, teachers teach the students following the contents in the textbook abstractly through teacher centered approach, and are seldom to show students practical work in the classroom. Therefore, the study has suggested that Cambodia should pay more attention to the reform of chemistry learning content in the textbook and ways of teaching together with developing available teaching materials in order to encourage and provide students with enough opportunities to explore scientific practical work.

II. DEVELOPMENT OF TEACHING MATERIALS

Addressing to the research question 2 (What teaching apparatus can be developed to support students' learning in chemistry at secondary school?) several teaching and learning apparatus and activities have been developed in this study aiming to enhance the chemistry classroom at secondary school in Cambodia as revealed in the research questions 1. The developed apparatus and lesson activities were selected and developed with high considerations such as they (1) are relevant and applicable in the Cambodian curriculum, (2) can be assembled from daily and inexpensive materials, and (3) are easy for students to operate in the classroom.

1. Development of teaching materials for lessons on detergent

Several properties of detergent such as the role of active surfactant on water surface tension had been investigated at different concentrations in this study together with a number of developed hand-made apparatus. The research has proposed the investigation of water surface tension by several simple methods such as marbling ink, capillary rise and weighing water drops, which used only painting ink, glass capillary tube and plastic syringe. In terms of the determination of detergent concentration and the intermolecular force in the aqueous

solution, the research has proposed a fabric dyeing method which is a new analytical method and used only some pieces of cloth and dyes without any organic solvents.

Through the application in the real classrooms in both Japan and Cambodia, the students could work well and actively with those developed apparatus and activities in the lessons to achieve the lesson objectives. The students could discuss and present well about the water surface tension and the molecular interactions in the solutions which is one of the basic chemistry concepts through their study of detergent concentration in the sample solutions. The particle interactions such as the combination of cationic and anionic particles, the repulsion of anionic and anionic particles, interaction of solutes and solvents, and the adsorption mechanism could be understood well by the students.

2. Development of teaching materials for lessons on conductivities

In case of the conductivity of aqueous solution, the study has developed a hand-made conductivity meter from simple, available and cheap materials, while the commercial conductivity meter is expensive for school. The hand-made meter was constructed based on a Kohlrausch bridge with inexpensive materials. It can be used to measure the conductivity of daily solutions such as fruit and vegetable juices and drinks. The conductivity values collected from the hand-made apparatus showed only slightly different from those collected by the commercial one. The developed materials and the lesson activities on the concept of solution conductivity were evaluated through the lessons with the real secondary students in both Japan and Cambodia. The students could operate the hand-made apparatus and all lesson activities to examine the conductivity of their daily solutions in the classroom without difficulty. Through the lessons, the students could interpret several scientific theories and phenomena such as to examine the total contents in a solution, the mobility of ionic particle, the strength of electrolyte, the solubility of substance, etc. The acid-base titration which was

developed in the activities also could help students to get clear images between the relationship of the conductivities values to the total contents in the solutions.

For the conductivity of the thin film semiconductor, the research has developed another hand-made device. The apparatus was developed based on a four-point probe technique which is believed to provide more precisely values than that of a two-point probe one. Similar to the conductivity of aqueous solution, this handmade device was easily assembled from inexpensive and available materials. The four-point probe chip was simply made without silver or lead paste. It provided a trouble-free measuring technique and reliable values consistent with those obtained by conventional devices. The study has also examined the conductivity of a semiconductor, polypyrrole, which was prepared by a polymerization of pyrrole through electrolysis and doped with several types of detergent as dopants.

Similar to the previous hand-made apparatus, this four-point probe conductivity measurement device was introduced to Japanese high school students in a lesson on polypyrrole and its conductivity. Through the lessons, the students could prepare their own polypyrrole, a conductive plastic, by electrolysis of pyrrole solutions and examined their conductive properties using the developed hand-made apparatus. The lessons could help students understand the properties of conductive polymers as a semiconductor, which rarely happen in real classrooms. The students could measure, discuss, compare and present their findings on the conductivity of several polypyrrole films with different surfactant dopants they make themselves in the classroom.

3. Development of teaching materials for lessons on viscosity of liquid

For this teaching materials, the study has developed an apparatus for a dropping ball method to investigate the effects of several metal ions with different sizes and charges on the viscosity of the aqueous sodium carboxyl methyl cellulose (CMC) solution, which is a polymer substance popularly used in food and cosmetics, as well as in the agricultural,

chemical and biological engineering fields. The apparatus has been developed from simple and inexpensive materials based on Ostwald method. The research also revealed the metal ions decrease the viscosity of the aqueous CMC solution within a particularly extent depending on the size of ionic charges. The metal ion with more charges contributes more drastically decreasing the viscosity of the aqueous CMC solution as it forms colloidal particles or precipitates with the CMC polymer.

The improvised apparatus was introduced to high school students in a lesson on viscosity and intermolecular interaction where the students could examine the viscosity of several solutions and compare it with an aqueous sodium CMC solution. The results from the pre/post tests and the questionnaires indicated that lessons could help the students to understand the intermolecular force such as aggregations between CMC molecules and metal ions which is a reason for the decrease of the viscosity of a CMC solution.

III. STUDENTS' PERCEPTION ON THE DEVELOPED MATERIALS

Addressing to the research question 3 (What are secondary school student's perceptions on the teaching and learning apparatus which were developed?, most of the students satisfied and enjoyed with the introduced activities and materials in the lessons. According to the author's observation in the classroom, the students showed high interest to the developed apparatus as they saw many daily materials were used in its construction and just wanted to move quickly into the experimental parts. This showed that the developed materials could effectively attract and hook the students' interests and engage them into the lesson more oriented. This observation results were in accord with the students' responding in the questionnaires at the end of the lessons. As already discussed in each chapter on the development of teaching materials from chapter 3 to chapter 6, most of the students confirmed in all the introduced lessons that they enjoyed using those developed materials and

working on the activities to investigate the given scientific problems and met the objectives of the lessons. They also evaluated that the teaching and learning materials that have been introduced to them could significantly be used feasibly by other students at the secondary levels to improve their relevant scientific knowledge and skills.

In summary, the study revealed the current level of students' competency in chemistry at lower secondary level compared to the countries in the region, as well as the international standards. This finding provides a very important baseline, it which it can be also used to develop a perspective to improve the quality of science education at the Cambodian school level to meet the regional and international standards. The research also provided a number of new developments of teaching and learning apparatus from available materials in daily life. Those developed apparatus can be suggested to use in the chemistry classroom as well as the physics classroom to enhance the quality of students' learning in order to obtain the relevant knowledge and skills in science, not only in Cambodia as a developing country but also in other countries around the world which want to explore the students to the practical works.

APPENDIX FOR CHAPTER II

TIMSS-2011 Standard Test

Chemistry Grade 8

1. Bob did an experiment to investigate the effect of temperature on the solubility of sugar in water by measuring the amount of sugar that would dissolve in 1 liter of water at different temperatures. He then plotted his results. Which of the following is like likely to be the graph showing Bob's results?

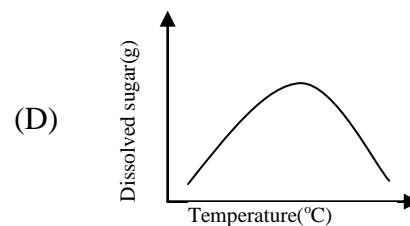
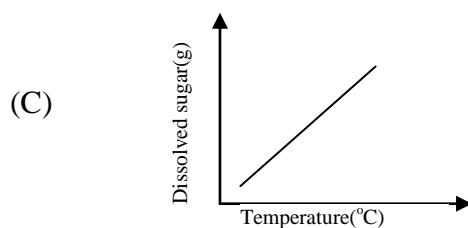
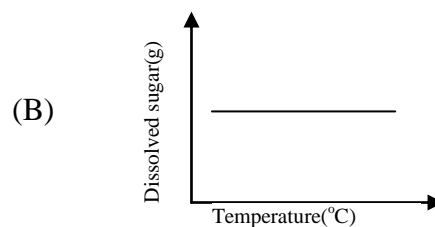
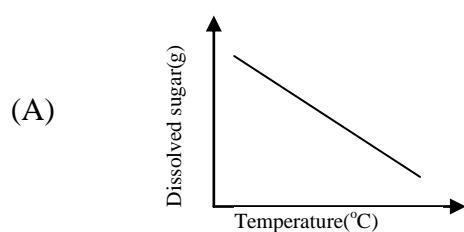

2. As shown in the diagram, the balloon is inflated when sodium bicarbonate is mixed with vinegar in the bottle. What cause this happen?

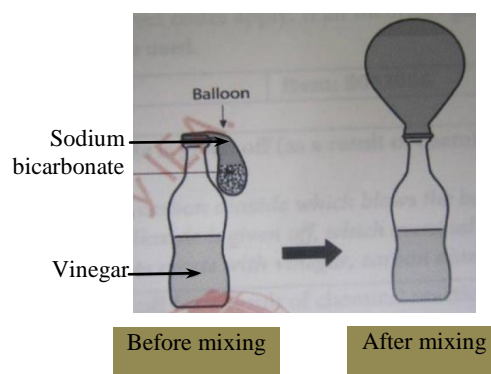

3. A car tire runs over a can and crushes it completely. Which statement is true for the atoms in the structure of the can?

- (A) The atoms are broken. (B) The atoms are flattened.
 (C) The atoms remain the same. (D) The atoms are changed into different atoms

4. Some physical properties of five different substances (A, B, C, D and E) are outlined in the table below. Two of the substances are metal.

	SubstanceA	SubstanceB	SubstanceC	SubstanceD	SubstanceE
Physical state at room temperature (25 °C)	Solid	Solid	Liquid	Liquid	Gas
Color	Shiny grey	White	Silver	Colorless	Colorless
Conducts electricity	Yes	No	Yes	Yes	No

List the two substances (A, B, C, D or E) that are metal.

1. _____ 2. _____

5. Why can a small fire be put out by placing a heavy blanket over it?

- (A) this lowers the temperature. (B) This makes the flames smaller.
 (C) This absorbs the burning substance. (D) This keeps oxygen from reaching the fire

6. Scientists think that the rocks in the picture were once a single rock. Which property of water had the most effect on splitting the rock into two pieces?



- (A) Water expanding when it freezes (B) Water boiling at 100 °C
 (C) Water having a density less than rock (D) water dissolving many substances

7. Complete the table below to show the number of atoms of each element in a molecule of sulfuric acid (H_2SO_4).

Element	Number of Atoms
Hydrogen	
Sulfur	
Oxygen	

8. Which of the following defines a compound?

- (A) Different substances mixed together
- (B) atoms and molecules mixed together
- (C) atoms of different elements combine together
- (D) atoms of the same element combined together

9. Ahmet put some powder into a test tube. He then added liquid to the powder and shook the test tube. A chemical reaction took place.

Describe two things he might observe as the chemical reaction took place.

1.
2.

10. In the diagrams below, hydrogen atoms are represented by white circles, and oxygen atoms are represented by black circles. Which of the diagrams best represents water?

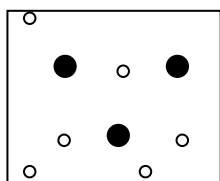

(A)

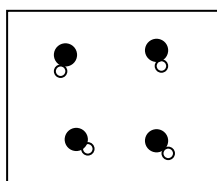

(B)

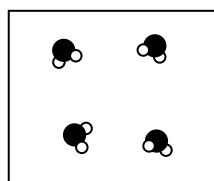

(C)

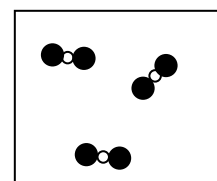

(D)

11. Write down one thing you might observe that shows that energy has been released during a chemical reaction.

12. What is the chemical formula for carbon dioxide?

- (A) CO (B) CO₂ (C) C (D) O₂

13. Robert put two drops of an indicator into vinegar, and the color turned red. He then added drops of ammonia solution until the color disappeared. What process occurred?

- (A) rusting (B) melting
(C) evaporation (D) neutralization

14. During which chemical process is energy absorbed?

- (A) Iron nails rusting (B) Candles burning
(C) Vegetables rotting (D) Plants photosynthesising

15. Rods made of different materials are connected between points P and Q in the circuit

diagram shown below.

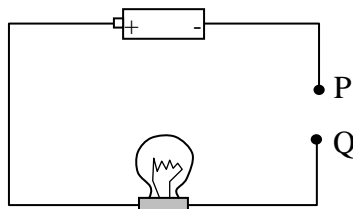

Which rod would cause the bulb to light?

- (A) copper rod (B) wood rod
(C) glass rod (D) plastic rod

16. The table below shows some elements, compounds and mixtures. Classify them by putting an X in the appropriate column beside each one.

	Element	Compound	Mixture
Air			
Sugar			

Salt			
Gold			
Sea water			
Helium			

17. Which of these diagrams best represents the structure of matter, starting with the more complex particales at the top and ending with the more fundamental particles at the bottom?

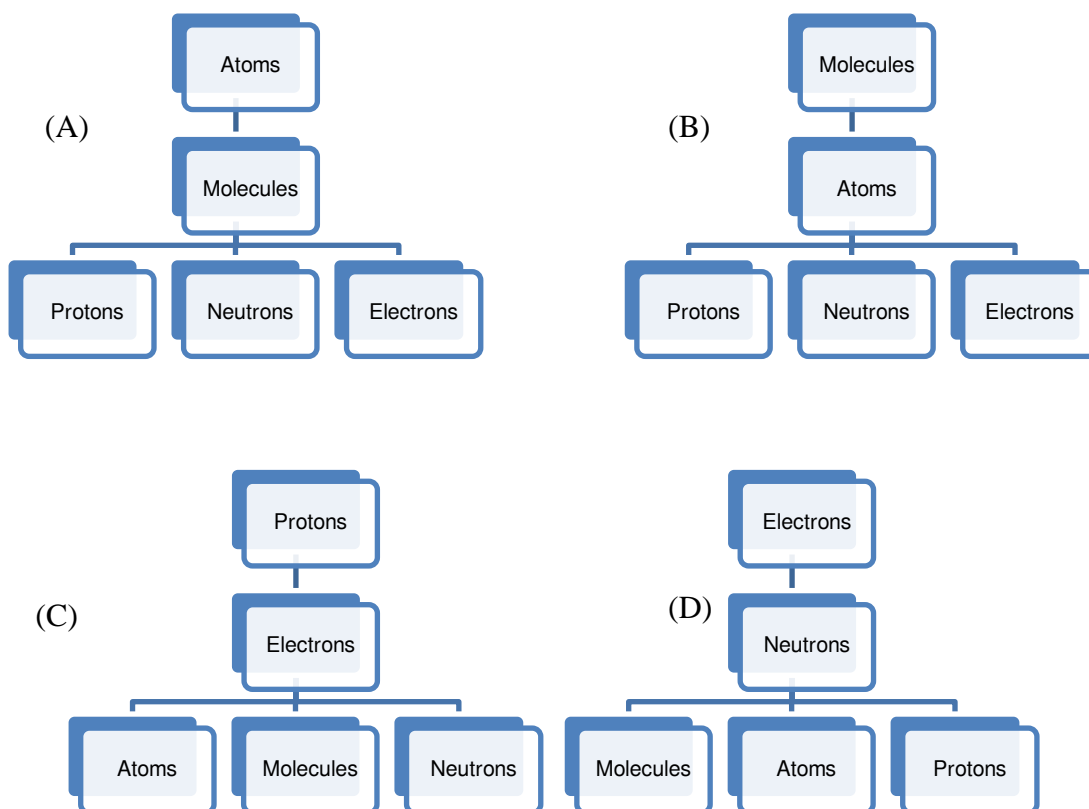

18. David is given a sample of an unknown solid substance. He wants to know if the substance is a metal. Write down one property he can observe or measure and describe how this property could be used to help identify whether the substance is a metal.

Type of Questions:

Question	ID	Block_Seq	Content Domain	Cognitive Domain
1	S032156	S01_04	Chemistry	Reasoning
2	S032056	S01_05	Chemistry	Applying
3	S052152	S02_06	Chemistry	Applying
4	S052136	S02_07	Chemistry	Reasoning
5	S052046	S02_08	Chemistry	Knowing
6	S052254	S02_09	Chemistry	Reasoning
7	S042076	S03_06	Chemistry	Knowing
8	S042306	S03_08	Chemistry	Knowing
9	S042100	S03_11	Chemistry	Knowing
10	S032502	S05_05	Chemistry	Applying
11	S032679	S05_06	Chemistry	Applying
12	S042073	S06_01	Chemistry	Knowing
13	S042095	S06_05	Chemistry	Knowing
14	S042112	S06_11	Chemistry	Knowing
15	S042063	S06_07	Chemistry	Applying
16	S042305	S06_10	Chemistry	Applying
17	S032579	S07_05	Chemistry	Applying
18	S032570	S07_06	Chemistry	Reasoning

Total: - Knowing = 7 Questions

- Applying = 7 Questions

- Reasoning = 4 Questions

APPENDIX FOR CHAPTER III

I. Student worksheets on detergent

<Worksheet 1: Soap and detergent properties>

Objective

To let students observe the similar and different properties between soap and detergent.

Materials and reagents

Three pieces of cloth (each piece approximately 10 cm x 10 cm), three beakers or transparent plastic cups, four test tubes and four stoppers, a dropper, liquid detergent, soapy water, soft water (tap water *or* pure water), hard water (Ca^{2+} solution).

Procedure

(1) Dirt-removing ability

1. Put tap water into three transparent plastic cups, up to about 80% of their volume, and then add some liquid detergent to one, and soapy water into another. Add nothing to the third glass. Stir the solutions well to make them homogenous.
2. Spill some oil onto the 3 pieces of cloth and then put one into each glass.
3. Observe what you see.

Glass with	Observation
Water	
Soap	
Detergent	

(2). Lathering ability in soft and hard water

1. Fill two test tubes to about one third with soft water and fill another two test tubes to one third with hard water (solution with Ca^{2+}).
2. Into one of the soft water test tubes, add 2-3 drops of soapy water, and into the other add 2-3 drops of detergent.
3. Stopper and shake the two test tubes. Compare the amount of bubbling in each test tube.
4. Repeat the same procedure (B-2 to 3) with the hard water test tubes.

	Observation	
	In soft water	In hard water
Soap		
Detergent		

(3) Acidity (pH)

1. Measure pH of soap and detergent solution by using a pH meter.

Solution	pH value
Soap	
Detergent	

(4) Precipitation in acid solution (vinegar)

1. Put about 10 mL of pure water into two test tubes.
2. Add 2-3 drops of soapy water into one and 2-3 drops of detergent into the other.
3. Add about 5 mL of vinegar into each test tube and shake well.

4. Observe what you see.

	In acid solution
Soap solution	
Detergent solution	

Conclusion

What similarities and differences did you find between soap and detergent?

<Worksheet 2: Let make soap and detergent molecules by atomic models>

Objective

- To explain the general function of soap and detergent molecules.
- To describe the similarities and differences between soap and detergent molecules.

Question

1. Do you know what substances are used to make soap? Select statements which you think are correct.
 - ❶ Grease and wood ash
 - ❷ Acid and alkali
 - ❸ Tri-glycerin and alkali
 - ❹ Fatty acid and alkali
2. By using atomic models, we can make the following soap and detergent molecules. Could you tell which molecule is soap and which is detergent?

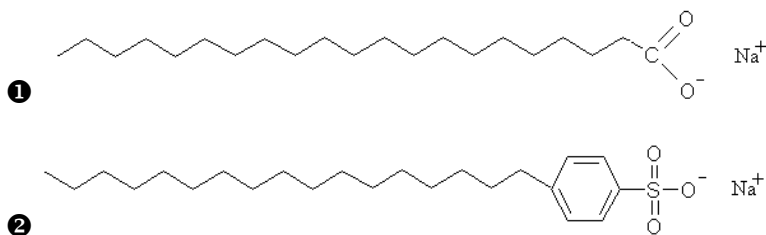

3. On the molecule of soap and detergent, label the two parts **hydrophobic**, which likes oil, and **hydrophilic**, which likes water.

4. Describe the main difference between the molecule of soap and detergent.

<Worksheet 3: Let's play with a water strider>

Objective

To get students to think about the surface tension of water and to consider the effect of soap or detergent on surface tension of water.

Material

A water container, a hand-made water strider or a paper clip, a dropper, liquid detergent and tap water.

The following diagram shows how to make a 'water strider' from steel-fiber.

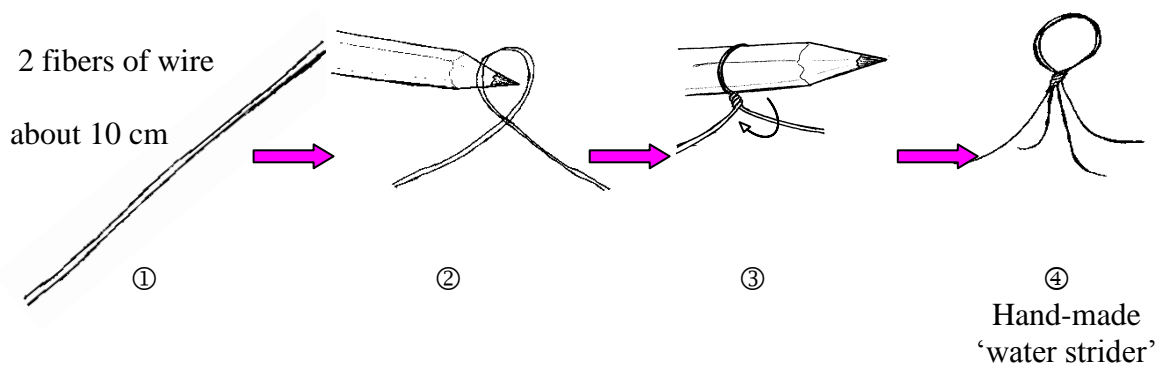

Procedure

1. Rinse a water container until you are sure that it is very clean, without any traces of soap or detergent.
2. Fill the water container half full of cold water and leave it to stand on a table.
3. Carefully put a hand-made 'water strider' on the water surface. See what happens.
4. Add a very small drop of liquid detergent into the water a far distance from the hand-made 'water strider'. See what happens.

Note: Using a transparent water container is better for making observations.

Results Table

Hand-made water strider/paper clip	Observation
before dropping detergent	
after dropping detergent	

Discussion

Say what you think about what happened to the hand-made water strider.

- Before dropping detergent: _____

- After dropping detergent: _____

<Worksheet 4: Effect of detergent on water surface tension by capillarity>

Objective

To examine the effect of detergent on water surface tension

Materials

Capillary glass tube, beaker or transparent plastic cup, ruler which can read in millimeters.

A commercial detergent with concentration of 0.05%, 0.025%, 0.0125%, 0.00625%, 0.003125% and pure water

Prediction

In this experiment, you will investigate water surface tension by observing the height of water rising up a capillary glass tube. So, what will happen to the rise in height up the capillary glass tube of water containing detergent? Select one of following answers:

- It gets higher
- It is lower
- It is the same height (no change)



 To confirm your prediction, let's conduct an experiment!

Procedure

1. Fix a capillary glass tube onto a ruler with tape. The lower end of the capillary tube should be adjusted to be under the zero mark of the ruler, as shown in following Fig..
2. Dip the ruler with capillary glass tube into pure water.
3. Adjust the level of the water surface to the zero mark of the ruler, and then record the rise in height in the capillary tube.

4. Repeat the above steps 1-3 for each detergent solution.

Note: Use a different capillary tube for each different sample.

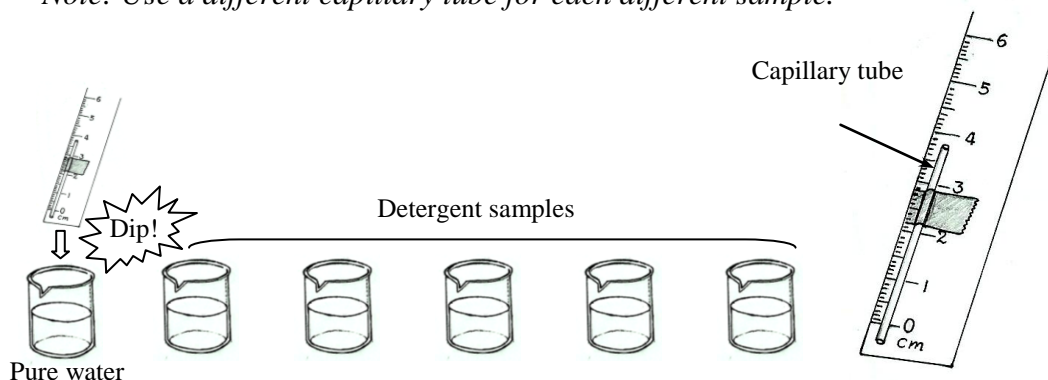

Results and discussion

1. Plot a graph of the rising height of sample against the detergent concentration.

Samples	Raising height
Pure water	
0.003125%	
0.00625%	
0.0125%	
0.025%	
0.05%	

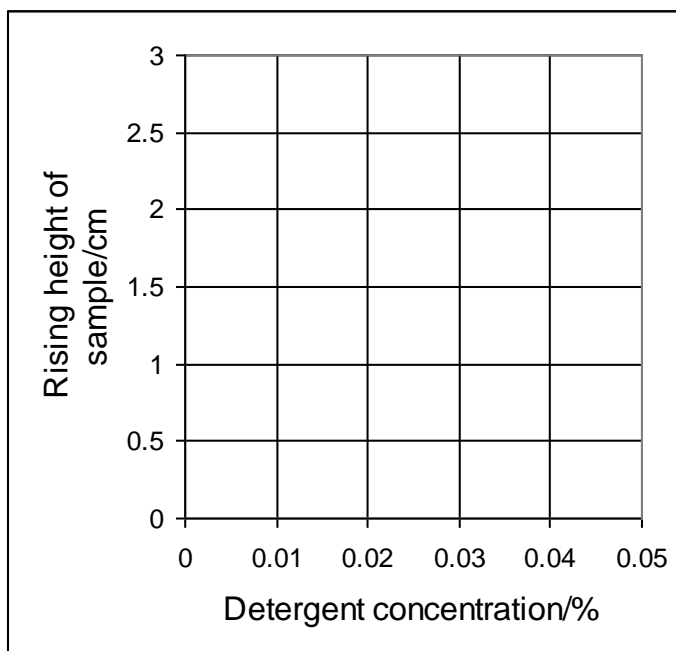

2. What happens to the rise in height of sample when the detergent concentration increases?

<Worksheet 5: Effect of detergent on water surface tension by water drop>

Objective

To examine the effect of detergent on water surface tension

Materials

A 50 mL Erlenmeyer flask; a set of apparatus which consists of a 1 mL plastic syringe connected to an L-shaped glass tube (inner diameter: 3mm and outer diameter: 5 mm) fitted with a rubber stopper (see following Fig.); an extra rubber stopper; an electric balance that can read 0.01 g.

A commercial detergent with concentration of 0.05%, 0.025%, 0.0125%, 0.00625%, 0.003125% and pure water

Prediction

In this experiment, you will investigate the effect of detergent on water surface tension by observing the weight of water drops. Therefore, what do you think will happen to the weight *or* size of a water drop containing detergent? Select one of following answers:

- Weight is lighter *or* size is smaller.
- Weight is heavier *or* size is bigger.
- There is no change to weight *or* size of drops.



To confirm your prediction, let's conduct experiment!

Procedure

1. Weigh the empty Erlenmeyer flask with a rubber stopper and record the weight.



An empty Erlenmeyer flask with a stopper

2. Fill the syringe with distilled water (without air).

3. Carefully and very slowly push the syringe plunger so that the sample enters the Erlenmeyer flask drop by drop, by gravity not by force. Collect 10 drops of sample.

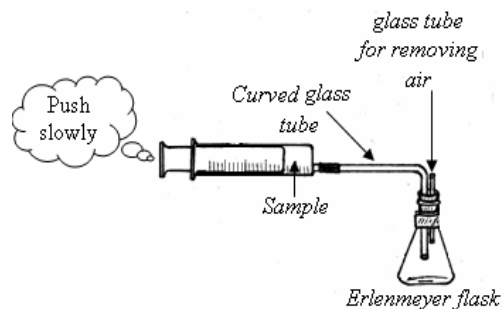

4. Weigh the Erlenmeyer flask with stopper and 10 drops of sample.

5. Pour away the sample inside the Erlenmeyer flask and wipe the mouth of the flask with tissue for the next sample solution.

6. Repeat the above steps 1-5 for each detergent solution.

Result

Sample	Weight of Empty Erlenmeyer flask (g)	Weight of the flask plus 10 drops (g)	Weight of 10 drops of sample (g)
Pure water			
0.003125%			
0.00625%			
0.0125%			
0.025%			
0.05%			

Discussion

1. Plot a graph of a drop weight of sample against the detergent concentration

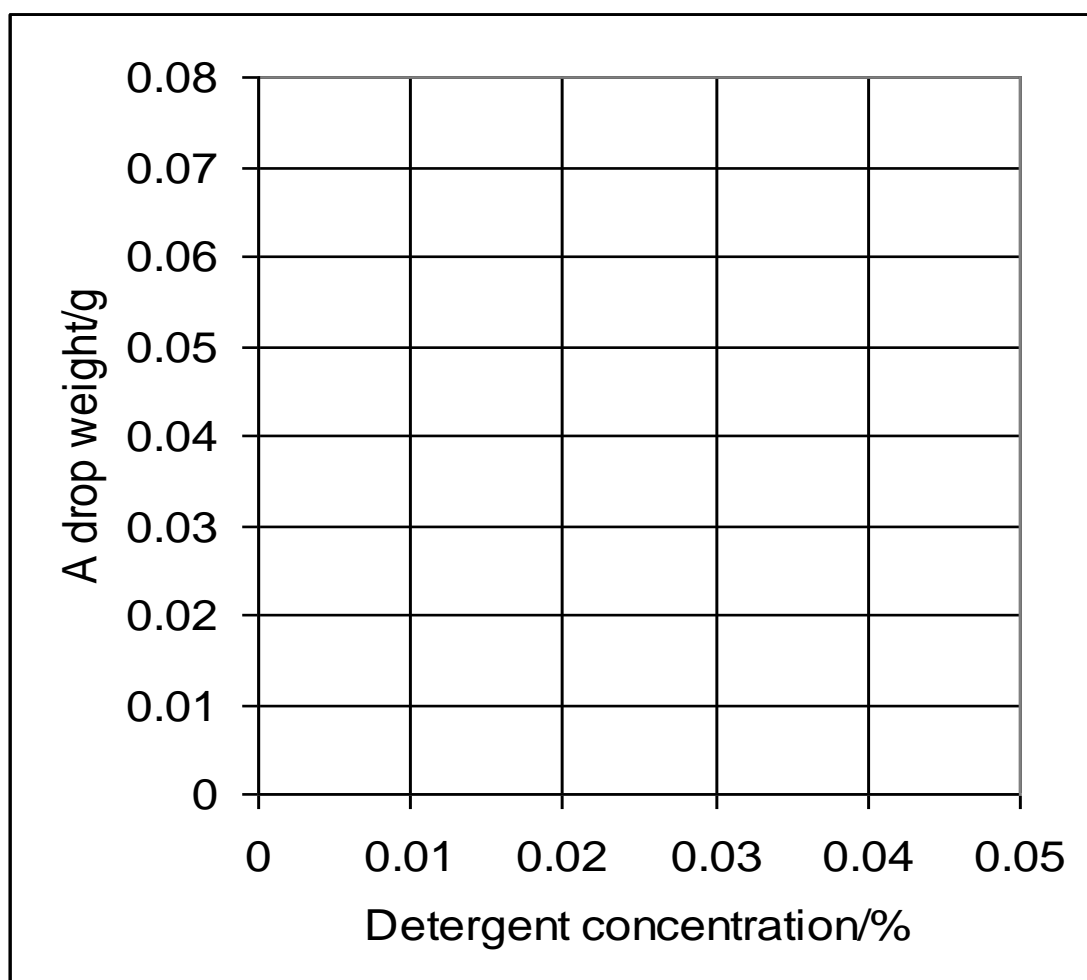

2. According to the graph of results, choose the appropriate word in the statements that follow:
-When the concentration of detergent (*increased/decreased*) the weight of sample drops (*increased/decreased*). Similarly, the size of a drop became (*bigger/smaller*) when the concentration of detergent (*increased/decreased*). This means the surface tension of water (*increased/decreased*) in the presence of detergent.

<Worksheet 6: Determination of detergent concentration in water by PONAL KIT ABS>

Materials

Cobalt complex tablet (ABS kit), absorbance machine (CO7500), 100 mL measuring flask, dropper, quartz (or small test tube).

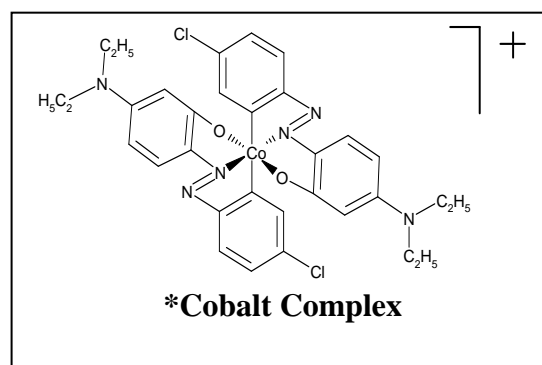

Sodium dodecyl sulfate in the concentration of 0.1 ppm, 0.2 ppm, 0.3 ppm, 0.4 ppm, 0.5 ppm and an unknown concentration.

Procedure

1. Fill the 100 mL measuring flask with 0.1 ppm.
2. Add 2 tablets of Cobalt Complex* and shake the solution well.
3. Add 4 mL of benzene and re-shake solution for about 3 minutes.
4. Let the mixture stand for about 5 minutes in order to allow the solution to separate into two phases.
5. Using a dropper, remove the upper layer (Benzene phase) of solution carefully and put it into a test tube and cap it.
6. Measure the absorbance of this benzene phase with an absorbance machine at 550 nm.
7. Repeat the same above steps from 1 to 6 for the other samples, including the unknown concentration.

Result

Plot a graph of the absorbance of sample against the detergent concentration and then determine the detergent concentration of the unknown.

Sample/ppm	0	0.1	0.2	0.4	0.5	unknown
Absorbance						

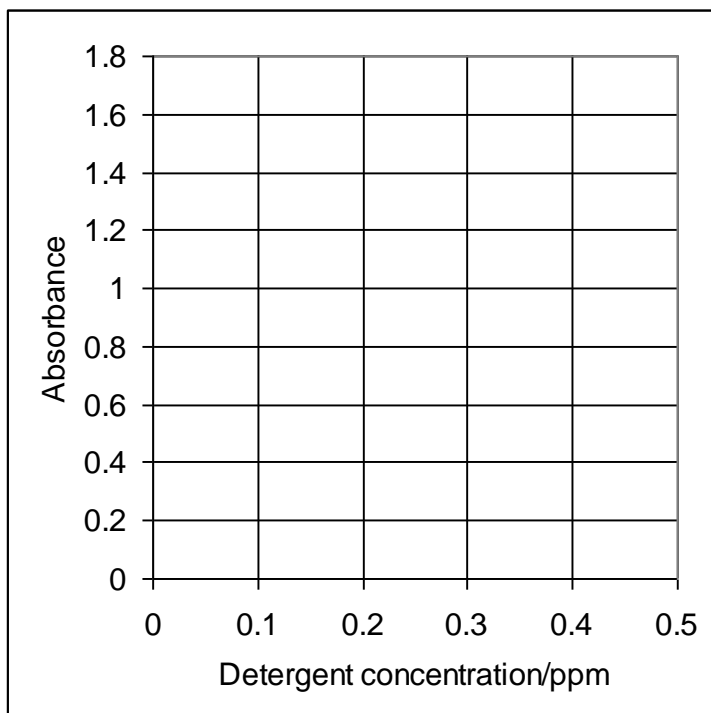

The detergent concentration of the unknown is: _____ ppm

<Worksheet 7: Determination of detergent concentration in water by fabric dyeing>

Material

100 mL beaker or glass or cup, 10 mL measuring cylinder, a pair of tweezers, white fabric (Cashimelon Acrylic type) in pieces ca. 4 cm x 4 cm, Hair dryer, reflection photo meter, and Multi meter,

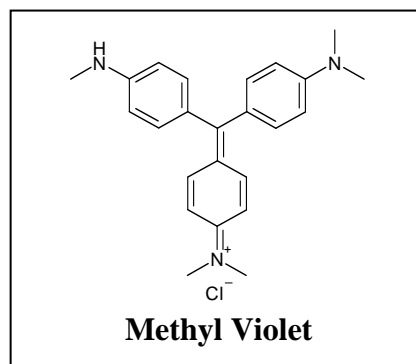

Sodium dodecyl sulfate in the concentration of 2 ppm, 4 ppm, 6 ppm, 8 ppm, 10 ppm and an unknown concentration; 0.005% w/v crystal violet solution (dye)

Procedure

1. Put 10 mL of pure water and each detergent solution including the unknown into a separate beaker.
2. Add 2 mL of crystal violet solution into each beaker, and stir the solutions about 1 min in the water bath at about 25 °C.
3. Dip a piece of the fabric into each solution for 15 min maintaining constant temperature of 25°C in the water bath.
4. By using forceps, remove the piece of fabric from the solution and dry it with a hair dryer.
5. Measure the color depth of dyed fabric with the photo reflection meter.

Result

Plot a graph of the color depth of dyed fabric against the detergent concentration and then determine the detergent concentration of the unknown.

Sample/ppm	Resistant/kΩ
0	
2	
4	
6	
8	
10	
Unknown	

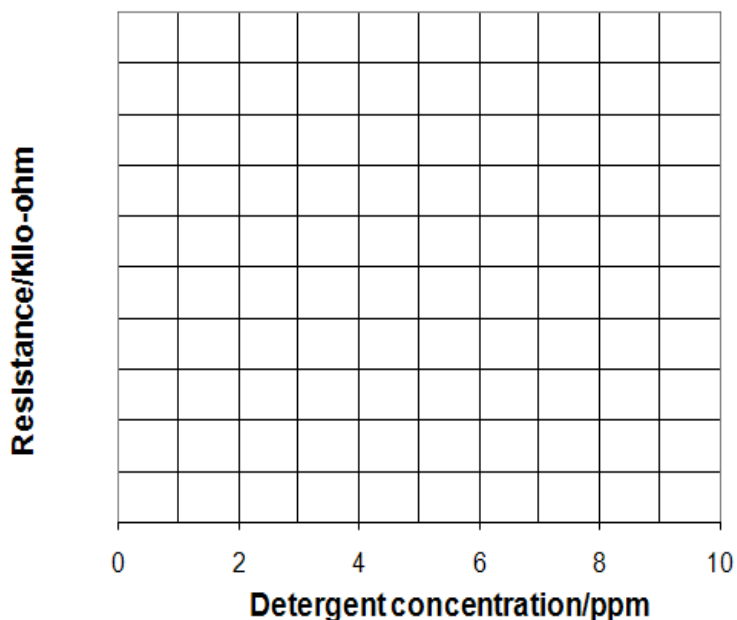

The detergent concentration of the unknown is: _____ ppm

<Worksheet 8: Application of the methods to environmental water>

Application 1

You have learnt how to examine the water surface tension and investigate the effect of detergent. By using this method, work in groups to investigate water samples from different places.

Method

- ① Each group has to collect three water samples from at least 3 different places.
- ② Investigate the samples using the drop weight method and record the results.

Result

Place name	_____	_____	_____
Appearance			
Weight of 10 drops			

Discussion

1. Discuss and give opinions about your results by relating to the characteristics of the sampling areas.

2. Compare your group results to the others.

3. Give your opinions about this activity.

Application 2

You have already learned some methods to determine detergent concentration in water in the classroom. Work in a group to apply the methods to investigate the detergent concentration in various water bodies around you. Therefore, your group has to collect water samples from at least three different places to determine the detergent concentration.

Name of the sampling area	Detergent concentration/ppm	
	PONAL KIT method	Fabric dyeing method

Discussion

1. Discuss and give opinions about your results by relating to the characteristics of the sampling areas.

2. Compare your group results with others and make a conclusion.

II. Lesson plan

<For the first period>

<p><u>Objectives</u> Students should be able to:</p> <ol style="list-style-type: none">i) Describe the similarities and the differences between soap and detergent.ii) Determine the water surface tension by drop weight.iii) Describe the effect of detergent on water surface tension.iv) Apply the drop weight method to the investigation of environmental waters. <p><u>Student's background</u> Students are supposed to know and have been familiar with water, soap and detergent through their daily use.</p>	<p><u>Activity</u></p> <ol style="list-style-type: none">i) Pre-tests (10 min)ii) Background review (5 min) Students tell some properties of soap, detergent and water.iii) Brainstorm (5 min)<ol style="list-style-type: none">1. Students brainstorm about the effect of detergent on water surface tension after a demonstration of a water strider.2. Students are asked to search for a definition of water surface tension by themselves and give their answers in the next lesson.iv) Activity (20 min)<ol style="list-style-type: none">1. Students give a prediction of the experimental results2. Investigate the effect of detergent on water surface tension by drop weight method. (Experimental results will be analyzed in the next lesson)v) Summary, homework assignment (10 min)<ol style="list-style-type: none">1. Teacher reviews what students have learned in this session.2. Students are asked by group to apply the drop weight method to the investigation of environmental waters and collect data for the next lesson.
--	--

<For the second period>

<p><u>Objectives</u> Students should be able to:</p> <ol style="list-style-type: none">i) Give the definition of water surface tension.ii) Analyze the experimental results from the first period lesson.iii) Present the results of the homework assignment. <p><u>Students background</u> Students are supposed to have been experienced with the investigation of the effect of detergent on water surface tension and applied the method to environmental waters.</p>	<p><u>Activity</u></p> <ol style="list-style-type: none">i) Back ground review (10 min) Teacher asks students to review what they have learned in the previous period.ii) Analysis of experimental results (20 min)<ol style="list-style-type: none">1. Students are asked to plot a result graph on a big poster on the board.2. Students are asked to interpret the result graph and to compare with their predictions.3. Students are asked to discuss in groups and to explain the reasons why the drop weight decreased when the detergent concentration increased.4. Students are asked to give the definition of water surface tension.
---	--

	<p>5. Teacher gives a conclusion</p> <p>iii) Students' presentation of homework assignment results (15 min) Students are asked to present their investigation results and their opinions on environmental waters by group.</p> <p>iv) Summary (5 min) Teacher reviews what students have learned in this session.</p>
--	---

<For the third period>

<p><u>Objectives</u> Students should be able to:</p> <p>i) Determine detergent concentration in water by using PONAL KIT ABS method and fabric dyeing method.</p> <p>ii) Apply the methods to the investigation of water in the environment.</p> <p><u>Students background</u> Students are supposed to have been familiar with some detergent properties.</p>	<p><u>Activity</u></p> <p>i) Background review (10 min) Students review what they have learned in the previous lessons about detergent.</p> <p>ii) Activity (30 min) Students are asked to work in groups to determine the detergent concentration in water using two methods by following the experimental procedures in the worksheets given:</p> <ol style="list-style-type: none"> 1. PONAL KIT ABS method 2. Fabric dyeing method <p>Students are asked to collect experimental data which will be analyzed in the next lesson.</p> <p>iii) Summary, homework assignment (10 min)</p> <ol style="list-style-type: none"> 1. Teacher reviews what students have learned in this session. 2. Students are asked by group to apply the methods to determine the detergent concentration in environmental waters and collect data for the next lesson.
--	---

<For the fourth period>

<p><u>Objectives</u> Students should be able to:</p> <p>i) Analyze the experimental results from the previous lesson.</p> <p>ii) Present the results of the homework assignment.</p> <p><u>Students background</u> Students are supposed to have been experienced with the methods to determine the detergent concentration from the previous lesson and applied the methods to the investigation in environmental water.</p>	<p><u>Activity</u></p> <p>i) Background review (10 min) Teacher asks students to briefly review the two methods of determination of detergent concentration in water that they have learned in the previous lesson.</p> <p>ii) Analysis of experimental results (20 min)</p> <ol style="list-style-type: none"> 1. Students are asked to draw a result graph on a big poster on the board. 2. Students are asked to interpret the result graph. 3. Teacher reviews and gives the principle nature of an ionic detergent and a cation dye, then ask students to guess what
---	--

	<p>would happen if these two materials are mixed together.</p> <p>4. Teacher gives further explanation concerning the natures of solute and solvent. Then the complete mechanisms of chemical reactions in the methods are explained to students.</p> <p>iii) Students' presentation of homework assignment results (15 min) Students are asked to present their investigation results and their opinions on environmental waters by group.</p> <p>iv) Summary (5 min) Teacher reviews what students have learned in this session.</p>
--	--

III. Pre/Post-test

Name:.....

Answer the following questions by selecting the best answer.

1. Soap is made from the reaction between:

- Acid and alkali
- Fat acid and alkali
- Grease and alkali
- b and c are correct

2. Which is a molecule of soap among the followings?

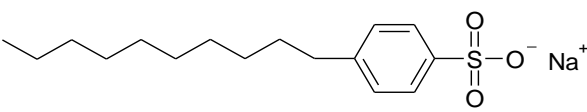
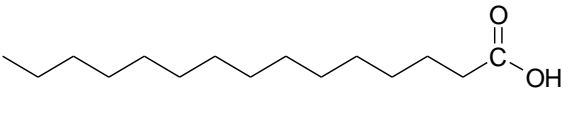
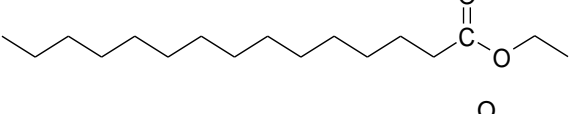
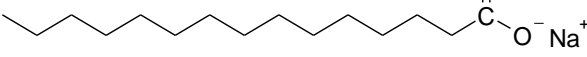
- 
- 
- 
- 

3. Which is a molecule of detergent among the followings?

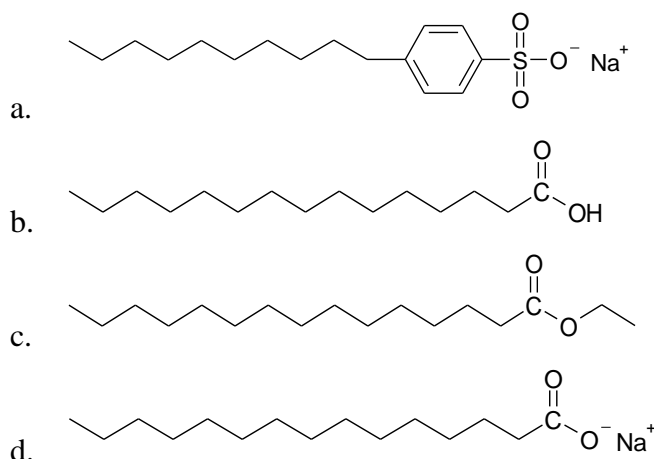

4. **Hydrophobic** part of soap or detergent is:

- its tail (alkyl chain), which likes water but doesn't like oil.
- its tail (alkyl chain), which doesn't like water but like oil.
- its head (anion group), which likes water but doesn't like oil.
- its head (anion group), which doesn't like water but like oil.

5. **Hydrophilic** part of soap or detergent is:

- its tail (alkyl chain), which likes water but doesn't like oil.
- its tail (alkyl chain), which doesn't like water but like oil.
- its head (anion group), which likes water but doesn't like oil.
- its head (anion group), which doesn't like water but like oil.

6. Soap or detergent can remove dirt from clothes (do washing) because of:

- It has a long chain in the molecule.
- It dissolves in water.
- Its tail (alkyl chain) can dissolve in water and its head (anion part) can dissolve in dirt, then the dirt is entrained in the micelle and suspended.
- Its tail (alkyl chain) can dissolve in dirt and its head (anion part) can dissolve in water, then the dirt is entrained in the micelle and suspended.

7. What does surface tension of water mean? _____

8. How detergent effects to the surface tension of water?

- The surface tension of water decreases in the present of detergent.
- The surface tension of water increases in the present of detergent.
- The surface tension of water decreases with small amount of detergent, but it increases again with big amount of detergent.
- The surface tension of water doesn't change even it contains detergent.

IV. Questionnaires

1. In general, how much did you understand today lesson?

- A. Clearly understood B. Understood
C. Somehow understood D. Did not understand at all

2. Write down three knowledge and/or skills that you learned and understood from the today class.

- (1). _____
(2). _____
(3). _____

3. How much did you interest in today lesson?

- A. Much interested B. Interested
C. Little interested D. Did not interest at all

4. Write down one concept and/or activity that you interested most from the today class.

- (1). _____

5. Do you think the improvised conductivity apparatus can be applied and used easily by other students at your school?

- A. Very easy B. Easy
C. Not too easy, but feasible D. Very Difficult

6. Write down one concept or one activity that you were not clear or did not understand (if any).

7. Write down one concept or one activity that you did not interest (if any).

8. More comments and suggestions:

APPENDIX FOR CHAPTER IV

I. Handouts for Students

<Conductivity>

What is conductivity? And how can we measure the value of conductivity?

Conductivity is the ability of materials to conduct electric current. A material with high conductivity is a good conductor. Conductivity units are defined as **Siemens per centimeter** ($S\text{ cm}^{-1}$).

The following diagram shows the assembly of an improvised apparatus that can be used to measure the conductivity of electrolyte solutions. The apparatus was designed based on **Kohlrausch bridge** theory.

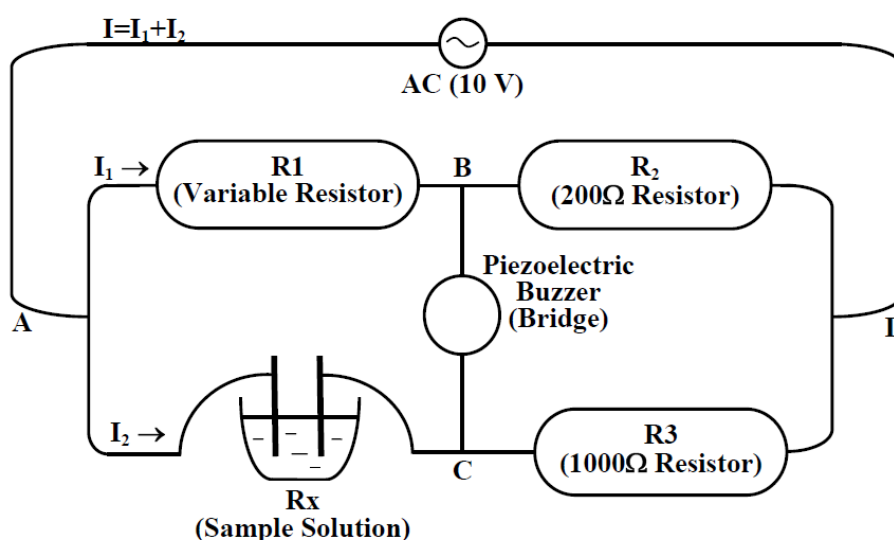

The conductivity value of the electrolyte solution can be known through determination of its resistance, R_x , by using Ohm's Law as in the following relationship:

- The potential difference between A and B is $E_{AB} = I_1 R_1$
- The potential difference between A and C is $E_{AC} = I_2 R_x$

When there is no difference of electric potential between B and C, the buzzer will not emit sound since there will be no current passing through it. Then,

$$E_{AB} = E_{AC} \Leftrightarrow I_1 R_1 = I_2 R_x \quad (1)$$

- The circuit constitutes a parallel connection. Therefore,

$$\Leftrightarrow I = I_1 + I_2$$

$$\Leftrightarrow E_{AB} + E_{BD} = I_1 R_1 + I_1 R_2 = 10.0 \text{ V}$$

also $\Leftrightarrow E_{AC} + E_{CD} = I_2 R_X + I_2 R_3 = 10.0 \text{ V}$

$$\Rightarrow I_1 R_1 + I_1 R_2 = I_2 R_X + I_2 R_3 \quad (2)$$

Due to (1): $I_1 R_1 = I_2 R_X \quad \Rightarrow \quad I_1 R_2 = I_2 R_3 \quad (3)$

Therefore (3) can be written as $\frac{I_1 R_1}{I_1 R_2} = \frac{I_2 R_X}{I_2 R_3} \Leftrightarrow \frac{R_1}{R_2} = \frac{R_X}{R_3} \Rightarrow R_X = \frac{R_1 R_3}{R_2}$

Since $R_2 = 200 \Omega$ and $R_3 = 1000 \Omega$, Then the resistance R_X can be defined as:

$$\Rightarrow R_X = \frac{R_1 \times 1000}{200} = 5R_1 \quad (4)$$

(where R_1 can be known by variable resistor)

Then, the **conductivity of electrolyte**, κ , is defined as the relationship with R_X by the following equation:

$$\kappa = \frac{l}{A} \times \frac{1}{R_X}, \text{ where } l \text{ is the distance between electrodes (cm) and } A \text{ is}$$

the surface area of electrodes (cm^2). However, $\frac{l}{A}$ is defined as the *cell constant* which

we can determine by experiment instead of measurement of l and A .

$$\kappa = \text{cell constant} \times \frac{1}{R_X} \quad (5)$$

II. Student Worksheets

<Practice: Determination of cell constant of the electrolyte solution>

According to the reference, the conductivity (κ) of 10 mM KCl is $0.0014114 \text{ S cm}^{-1}$ at 25°C . If you measure the resistance of KCl(aq), then, you can calculate the *cell constant* from the equation (5), where $\text{cell constant} = \kappa R_X$ (6)

Procedure

1. Connect the apparatus to AC potential transformer that is set to 10 V.
2. Transfer 15 mL of 10 mM KCl(aq) into the film canister. Put the electrodes into the film canister and then connect each end side of electrode with a clip.
3. Turn the variable resistor to the zero point so sound can be heard from the buzzer.
4. Then turn the variable resistor until the buzzer stops making sound. Record the value of resistance at this point, known as R_{low} .
5. Further, turn the variable resistor to reach the point that sound can be heard again and record the value at this point, known as R_{high} .
6. Wash the electrodes using distilled water and wipe with tissue to dry them.
7. Calculate R_1 as it is the average value of the midpoint between R_{low} and R_{high} . Then use this value (R_1) to find the resistance of solution (R_X).

	R_{low} (Ω)	R_{high} (Ω)	R_1 : midpoint between R_{low} . and R_{high} (Ω)	$R_X = 5 R_1$ (Ω)
10 mM KCl(aq)				

According to reference, conductivity of 10 mM KCl(aq) is $\kappa = 0.0014114 \text{ S cm}^{-1}$,

Then, $\Rightarrow \text{cell constant} = 0.0014114 \text{ S cm}^{-1} \times R_X$

$$= 0.0014114 \text{ S cm}^{-1} \times \dots\dots\dots = \dots\dots\dots \text{ cm}^{-1}$$

(Note: $1\text{S} = 1 \Omega^{-1}$)

<Conductivity of Electrolyte Solutions>

Questions: How does concentration affect the conductivity of an electrolyte solution?

Hypothesis: - when the concentration is increased, the conductivity will be

- when the concentration is decreased, the conductivity will be

Based on the above idea, which one of the following graphs do you think is most probably correct.

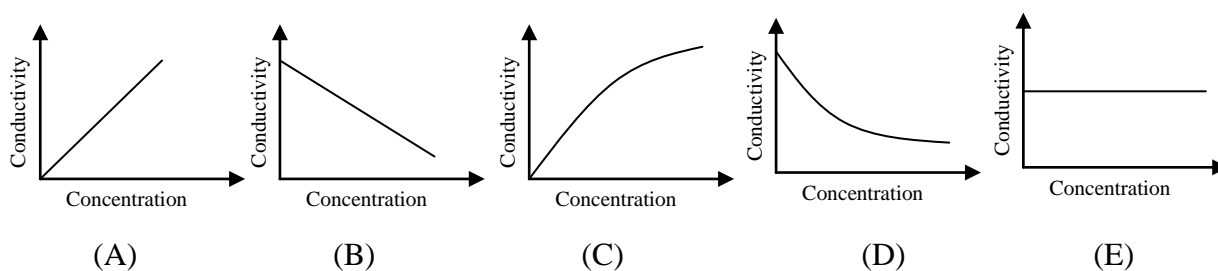

Experimental Procedures: Conductivity Measurement

Materials:

- Improvised apparatus, AC current transformer, electrolyte container (carbon rod electrodes and film case), washing bottle and tissue paper.
- Electrolyte solutions to be investigated are:
 - NaCl(aq) 10 mM, 12 mM and 14 mM
 - CuCl₂(aq) 6 mM, 8 mM and 10 mM
 - AlCl₃(aq) 6 mM, 8 mM and 10 mM
 - and 10 mM KCl(aq)

Procedure:

Check the apparatus connections to make sure that the system is connected as in the diagram shown above.

Measuring the conductivity of electrolyte solutions

1. Follow the same procedures as when measuring the *cell constant* (as shown in the student handout) from step 1 to 6 as mentioned in the **Handouts for Students** by using solutions of NaCl(aq), CuCl₂(aq) and AlCl₃(aq) one by one starting from the lower to the higher concentration.
2. Calculate the resistant of R_1 , then R_X and finally conductivity, κ , of all solutions by using the *cell constant* value you have determined.
3. Plot your data from procedure-8 in one graph showing the trends in conductivity of each solution at different concentrations.

Experimental Results:

Results of experimental procedure-8

	R_{low} (Ω)	R_{high} (Ω)	R_1 : midpoint between R_{low} and R_{high} (Ω)	$R_X = 5 R_1$ (Ω)	Conductivity κ (S cm ⁻¹)
10 mM NaCl(aq)					
12 mM NaCl(aq)					
14 mM NaCl(aq)					
6 mM CuCl ₂ (aq)					
8 mM CuCl ₂ (aq)					
10 mM CuCl ₂ (aq)					
6 mM AlCl ₃ (aq)					
8 mM AlCl ₃ (aq)					
10 mM AlCl ₃ (aq)					

Discussion:

(1). What changes of conductivity did you find?

.....
.....
.....

(2). Do these experimental results support your hypothesis?

.....
.....

(3). Write your conclusion:

.....
.....
.....

<Application of Conductivity>

Question:

Which is better to supplement your body when you lose a lot of sweat, Pocari Sweat or white radish juice?

Hypothesis: I think because

How can you test it?

We can test by.....

Today we will test and compare with other vegetables and fruit juices too

Experimental procedure:

1. Making radish juice: slice and grind 20 g white radish, then add 20 mL of water and stir well. Filter and collect the radish juice into a clean beaker.

2. By using the same procedures 1 to 6 as mentioned in the **Handouts for Students**, measure the resistance, then calculate the conductivity of POCARI WEAT and other vegetable and fruit juices.

Experimental Results:

Daily Drinks	R_{low} (Ω)	R_{high} (Ω)	R_I : midpoint between R_{low} and R_{high} (Ω)	$R_X = 5 R_I$ (Ω)	Conductivity κ ($S\ cm^{-1}$)
Pocari Sweat					
Carrot Juice					
Radish Juice					
Cabbage					
Orange Juice					
Apple Juice					

Discussion:

(1). Do your results support your hypothesis?

.....

(2). Now, can you suggest which drink should be used as a supplement when someone sweats? Why?

.....

<Titration of vegetables and fruits>

Materials:

- Burette, Erlenmeyer flask, beaker, stand,
- Distilled water, 10 mM HCl(aq), phenolphthalein,
- ash of 20 g radish, 20 g carrot, 20 g apple, 20 g cabbage, 20 g orange.

Procedure:

1. Set up the apparatus for titration as shown on the right.
2. Put each ash into a different beaker and add 50 mL of water to each. Stir about 2 minutes and filter to obtain the ash solutions.
3. Fill the burette with HCl(aq) and adjust to 0.0 mL level at the top.
4. Titrate slowly by pouring 20 mL of an ash solution into Erlenmeyer flask and add two or three drops of phenolphthalein.

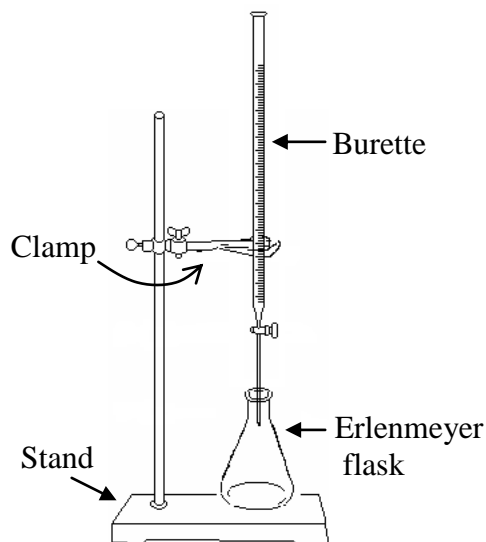

What color change do you observe? And what does it show about the nature of the ash solution?

5. Put the Erlenmeyer flask under the burette and start to drain the HCl(aq) slowly.
6. Shake the Erlenmeyer flask gently while draining the HCl(aq) into the flask, and close the burette valve immediately when the pink color disappears.
7. Read on the burette the volume of HCl(aq) used. Record the values into the table below.

Results:

Ash solution	Volume of HCl(aq) used to reach equivalent point
Carrot	
Radish	
Cabbage	
Orange	
Apple	

Discussion:

(1). Supposing that ash solution is mono basic, calculate the concentration of each ash solution you have measured.

.....
.....
.....

(2). Share your results with other groups and Compare the amount of electrolyte in order by its conductivity and titration measurement.

.....
.....
.....
.....

III. Lesson Plan

Lesson Duration: 3 periods

Objective: Through this lesson, students will be able to

- develop the concepts of conductivity and explain some factors that affect to conductivity value of electrolyte solution properly through their experimental results.
- use improvised conductivity apparatus to analyze the total dissolved materials in electrolyte solutions and apply this skill to their daily lives through several practical works during the class.
- increase their interests in science investigation through engaging with real hand on and mind on activities, especially for those involve in their daily lives.

Materials:

- A set of improvised apparatus, AC current transformer, washing bottle and tissue.
- Electrolyte solutions : NaCl(aq) in a ranges of concentration (0.005 mol/L to 0.050 mol/L),
sport drink, radish juice, carrot juice, apple juice, cabbage juice and orange juice.

Lesson Progress:

First Period: Conductivity Concept and Measurement (60 min)

Teaching and Learning's Activity	Materials
1. Greeting and Self-introduction	- Pre-assessment sheet
2. Pre-lesson assessment	
3. Reviewing concept of conductivity: What is conductivity? How to measure conductivity of an electrolyte solution?	- Student Handout
4. Introduce and explain how to use an improvised apparatus to measure conductivity of electrolyte solution, as well as the background theory that links to calculate the conductivity value by using this apparatus.	- Improvised conductivity meter - Projector

Second Period: Conductivity of Electrolyte Solution (60 min)

Teaching and Learning's Activity	Materials
<p>- Base on the concepts learned in session-1, introduce Key Question:</p> <div style="border: 1px solid black; padding: 10px; text-align: center;"> <p><i>How does concentration affect to conductivity of an electrolyte solution?</i></p> </div> <p>- Facilitate students to formulate hypothesis in groups.</p> <p>- Encourage students to think of how to investigate their hypothesis.</p> <p>- Confirm the experimental procedures to students</p> <p>- Allow students to measure conductivity of provided electrolyte solutions and fill the data in the worksheet. Help them in case of need</p> <p>- Encourage students to work in groups and discuss what they find out from their experimental data, then ask students to present their own conclusion.</p>	<p>- Student Worksheet-1</p> <p>- Improvised conductivity meter</p> <p>- NaCl(aq) in a range of concentration: 0.005 mol/L to 0.050 mol/L</p>

Third Period: Application of Conductivity (60 min)

Teaching and Learning's Activity	Materials
<p>- Tell a story of using POCARI SWEAT to supplement when we lose a lot of sweat and ask students to give some reasons.</p> <p>- Raise an opposite idea by saying some people use white radish juice instead of sport drink, do you agree? Then, link to a key question:</p> <div style="border: 1px solid black; padding: 10px; text-align: center;"> <p><i>Between POCARI SWEAT and white radish juice, which is better to supplement loss of sweat?</i></p> </div> <p>- Encourage students to formulate hypothesis filling into worksheet.</p> <p>- Encourage students to investigate other fruit juices such as carrot, apple, cabbage and orange, then make a comparison.</p> <p>- Confirm the experimental procedures to be clear to the students</p> <p>- Allow students to conduct the experiment and fill the result data in the worksheet.</p> <p>- Encourage students to work in groups and discuss what they find out from their experimental data, then ask students to present their own conclusion and suggest one appropriate drink to supplement ions when we have a lot of sweat.</p> <p>- Deliver Post-lesson assessment and Questionnaires</p>	<p>- Student Worksheet-1</p> <p>- Improvised conductivity meter</p> <p>- POCARI SWEAT, white radish juice, carrot juice, apple juice, orange juice,</p> <p>- Post-lesson assessment test</p> <p>- Questionnaires</p>

IV. Pre/Post-test

1. In your own understanding, what does **conductivity** mean?

.....
.....
.....

2. Taro-san had prepared 3 kinds of solutions.

Solution-X, she dissolved 1.0 g of LiBr(s) into 20 mL water.

Solution-Y, she dissolved 2.0 g of LiBr(s) into 20 mL water.

Solution-Z, she dissolved 3.0 g of LiBr(s) into 20 mL water.

What is the different **conductivity** comparing the three solutions?

A. $X = Y = Z$

B. $X > Y > Z$

C. $X < Y < Z$

Explain your selected

answer:
.....
.....

3. In your idea, river water and sea water which has higher conductivity? Why do you think so?

.....
.....

4. Government usually checks natural water property by measuring its conductivity. Do you think what conductivity result tells in this investigation?

.....
.....

5. Most people use POCARI SWEAT when they have a lot of sweat in summer or after doing exercise. In this case, is it possible to use a fruit juice instead of POCARI SWEAT?

A. Yes

B. No

C. I am not sure

Please give reasons to your selected answer:

.....
.....

V. Questionnaires

1. In general, how much did you understand today lesson?

- A. Clearly understood B. Understood
C. Somehow understood D. Did not understand at all

2. Write down three knowledge and/or skills that you learned and understood from the today class.

(1). _____

(2). _____

(3). _____

3. How much did you interest in today lesson?

- A. Much interested B. Interested
C. Little interested D. Did not interest at all

4. Write down one concept and/or activity that you interested most from the today class.

(1). _____

5. Do you think the improvised conductivity apparatus can be applied and used easily by other students at your school?

- A. Very easy B. Easy
C. Not too easy, but feasible D. Very Difficult

6. Write down one concept or one activity that you were not clear or did not understand (if any).

7. Write down one concept or one activity that you did not interest (if any).

8. More comments and suggestions:

APPENDIX FOR CHAPTER V

I. Handouts for Students

<Polypyrrole>

Polypyrrole (PPy) is a type of organic polymer formed by the polymerization of pyrrole, either chemically or electrochemically, through oxidation of pyrrole monomer. Polypyrrole is a well-known conductive plastic in recent technology. It is used in several modern electronic devices such as in mobile phones, computers and so on. It is also used for chemical sensors.

The oxidative polymerization proceeds via a one-electron oxidation of pyrrole to a radical cation, which subsequently couples with another radical cation to form *bipyrrole*. This process is then repeated to form longer chains.

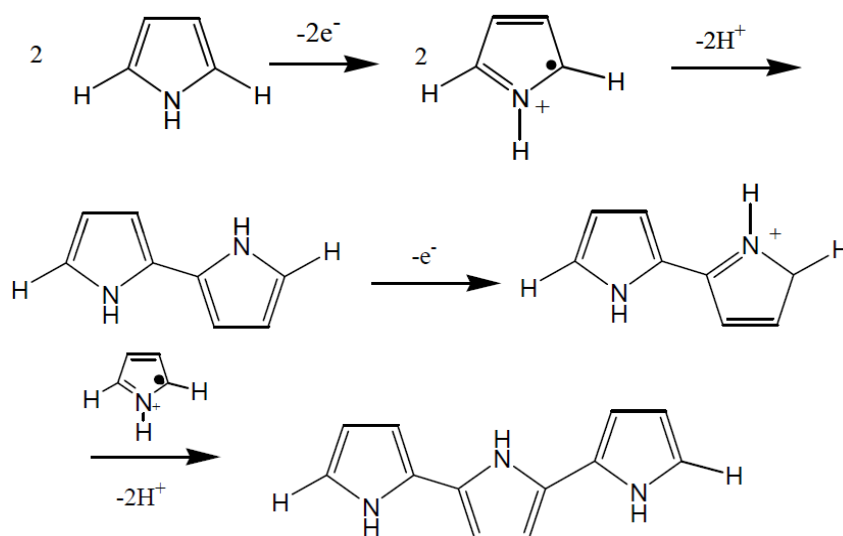

Polypyrrole has resonance structures that resemble the *aromatic* or *quinoid* forms. In these natural states the polymer is a non conductive material (an insulator).

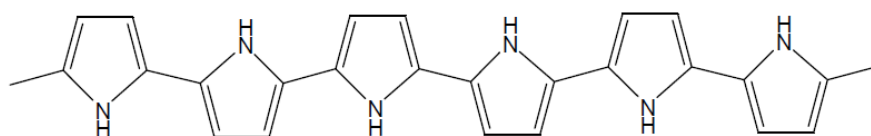

Aromatic

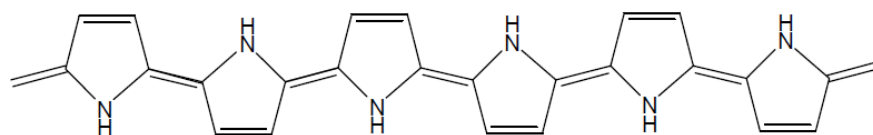

Quinoid

However, the polymer can become a good electrical conductor after it is oxidized (p-doping). The charge associated with the oxidized state is typically delocalized over several pyrrole units and can form a radical cation (*polaron*) or a dication (*bipolaron*) where the charges are neutralized by anions from a doping reagent (dopants). The polymerization and p-doping can proceed at the same time during electrolysis.

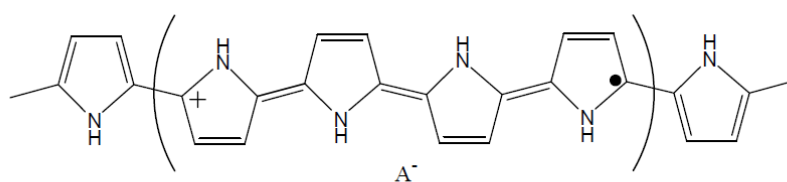

Polaron

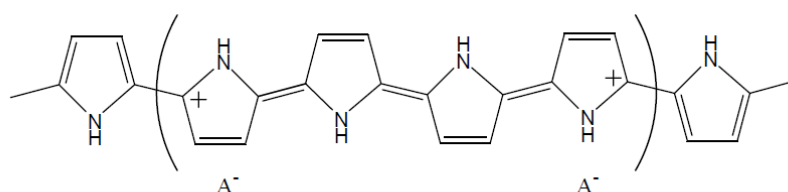

Bipolaron

The physical form of polypyrrole is usually an intractable powder resulting from chemical polymerization and an insoluble film resulting from electropolymerization. The films of polypyrrole are yellow but darken in air due to oxidation. Doped films are blue or black depending on the degree of polymerization and film thickness. They are stable in air to

150°C. Conductivities vary in a range depending on the conditions and reagents use in the oxidation. Higher conductivities are associated with larger anions (dopants).

II. Measuring Conductivity

The four-point probe technique is an appropriate measuring technique to measure ability to conduct electric current or *Conductivity*, of thin films like in the case of polypyrrole films. This technique is also sometimes, called 4-terminal sensing or 4-wire sensing. The technique uses separate pairs of wires as current-carrying (outer pairs: 1-4 electrodes) and voltage sensing electrodes (inner pairs: 2-3 electrodes) to make more accurate measurements. The separation of current and voltage electrodes eliminates the impedance of the wiring and contact resistances.

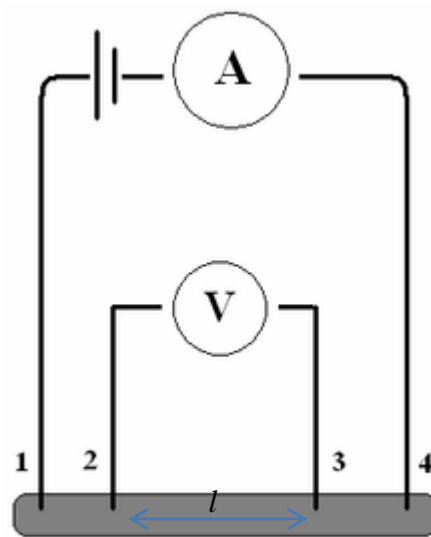

The conductivity can be simply calculated from a basic formula. When a current passes through the polypyrrole film with the length l , width w and thickness t then, the film resistance can be written as:

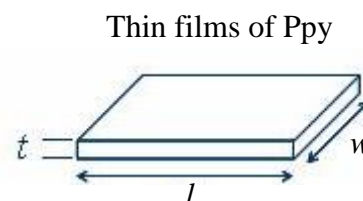

$$R = \rho \frac{l}{A} = \rho \frac{l}{wt}, \text{ where } A = wt \text{ (cross-sectional area, l) and } \rho \text{ is the resistivity}$$

$$\Rightarrow \rho = \frac{Rwt}{l}$$

Conductivity, κ , is defined as the inverse of resistivity. Therefore,

$$\kappa = \frac{1}{\rho} = \frac{l}{Rwt} \text{ where R can be calculated from Ohms Law: } R = \frac{V}{I} \text{ (V is voltage value}$$

shown by the inside pair of wires and I is current value shown by the outside pair of the 4T sensing.

II. Student Worksheets

<Preparation of Polypyrrole: a conductive plastic>

Materials

- 200mL beakers, 100mL measuring cylinder, glass rode, stainless plates, DC-transformer or 3 dry cells, electronic scale.

- Pyrrole (C_4H_4NH),

- Surfactants:

Sodium dodecyl sulfate (SDS): $CH_3(CH_2)_{11}OSO_3^-Na^+$

Sodium dodecylbenzensulfonate (SBD): $CH_3(CH_2)_{11}C_6H_4SO_3^-Na^+$

Sodium Naphthalene-2-disulfonate (SNS): $C_{10}H_7SO_3^-Na^+$

Disodium Naphthalene-1,5-disulfonate (SNDS): $C_{10}H_6(SO_3^-Na^+)_2$

Sodium Laurate (SL): $CH_3(CH_2)_{10}COO^-Na^+$

Soap: $R - COO^- Na^+$

- Distilled water & tissue paper

Procedures

1. In a 200mL beaker, put 0.335g pyrrole, 1.0g of surfactant and add 100 mL of distilled water. Stir to completely dissolve.
2. Dip two stainless plates (electrodes) into the solution and connect the electrodes to 4.5V DC power supply. Observe!
3. Stop the electrolysis after 10 minutes. Then, carefully remove the two electrodes from the beaker to wash with distilled water and dry by sandwiching with filter paper.
4. Repeat procedures (1-3) with other surfactants.

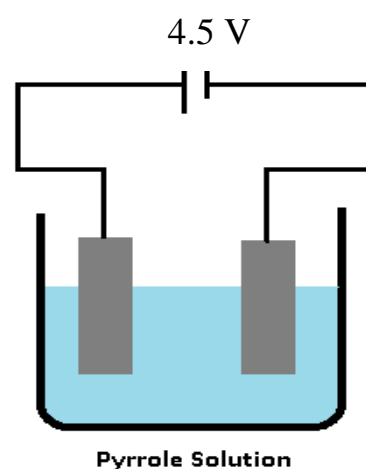

Observation

	Observation: Any different apparent between the four films?
Polypyrrole-SDS	
Polypyrrole-SBS	
Polypvtyrrole-SNS	
Polypyrrole-SNDS	
Polypyrrole-SL	
Polypyrrole-Soap	

<Measurement of Polypyrrole Conductivity>

Materials6

Polypyrrole Films, Four-point probe handmade device, multimeter, DC-current supply, scissors, tape, ruler, calipers.

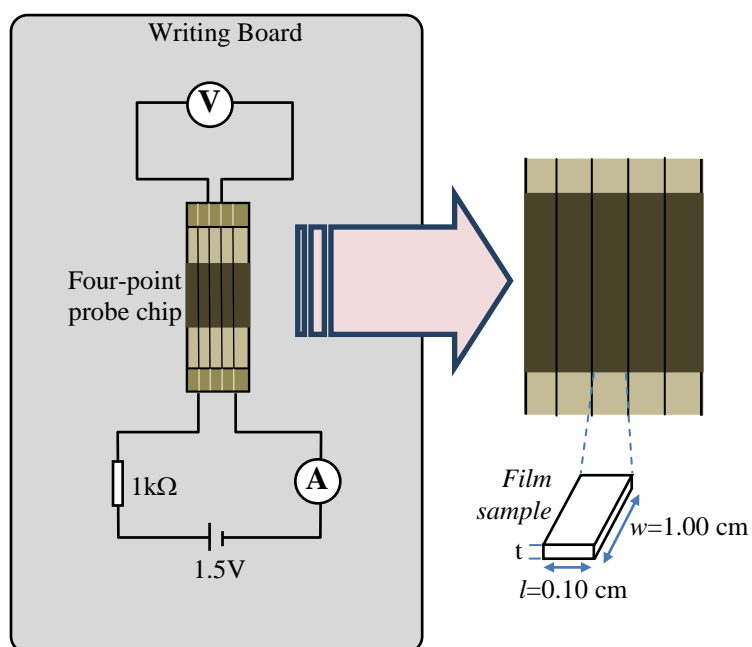

Diagram of four-point probe Handmade Conductivity Device

Procedures

1. Make sure that the device is well connected to 1.5 DC power source and the two multimeters, one for voltage and the another for current detection.
2. Stick adhesive tape to the polypyrrole film on the electrode plate you have produced and then remove the tape. The polypyrrole film now sticks onto the tape.
3. Cut the tape coated with the polypyrrole film to size, 1.0cm × 1.0cm.
4. Place the cut film in between plastic board and the 4 wire (electrodes) of the four-point probe chip of handmade device.
5. Push the raised side of the board with your finger, so that the 4 wire electrodes make good contact with the film.
6. Record voltage and current value on the multimeters.
7. Measure the thickness of the film by using calipers.
8. Calculate conductivity of each film from the following relationship.

$$\text{Conductivity, } \kappa = \frac{1}{\rho} = \frac{l}{Rwt}$$

where resistance $R = \frac{V}{I}$ (V is voltage, I is current),

On this device, width of the film $w = 1.0\text{cm}$, length of the film $l = 0.1\text{cm}$

$$\text{Therefore, Conductivity } \kappa = \frac{0.1}{Rt}$$

Results

Polypyrrole film doped by...	Voltage (V)	Current (A)	$R = \frac{V}{I}$(Ω)	Thickness,t (cm)	$\kappa = \frac{0.1}{Rt}$ (S cm⁻¹)
SDS					
SBS					
SNS					
SNDS					
SL					
Soap					

Discussion

Compare with others. What are your findings?

III. Lesson Plan

Lesson Duration: 3 periods

Objective: Through this lesson, students will be able to

- develop the concepts of polymerization of polypyrrole and its special characteristic as a conductive plastic, as well as build up physical knowledge in terms of conductivity calculation of a material.
- prepare various polypyrrole films with various dopants and compare their properties and conductivity by using an improvised the four terminal sensing apparatus.
- increase their interests in science investigation and link today concepts to the current technology application of polypyrrole.

Materials:

- A set of four terminal sensing improvised apparatus, DC current transformer, washing bottle, tissue paper, tape, calipers, 200mL beaker, stainless plates.
- Pyrrole, Sodium Dodecyl Sulfate (SDS), Sodium Dodecylbenzene Sulfate (SBS), Sodium Naphthalen -1,5-disulfate (SNDS), Sodium Laurate (SL), Distilled water.

Lesson Progress:

First Period: Polypyrroles Polymerization (60 min)

Teaching and Learning's Activity	Materials	
1. Greeting and Self-introduction 2. Pre-lesson assessment 3. Lesson introduction: Each student gives one material that can conduct electricity. Then a key question is asked:	- Pre-assessment sheet - Student Handout	
<table border="1"><tr><td data-bbox="185 1879 1019 1962">Do you think a typical plastic can conduct electricity? Why?</td></tr></table>	Do you think a typical plastic can conduct electricity? Why?	
Do you think a typical plastic can conduct electricity? Why?		

<p>Today we will prepare and observe a case of polypyrrole.</p> <p>3. Reviewing concept of Polymerization and properties of polypyrrole as a conductive plastic.</p>	
--	--

Second Period: Polypyrrole preparation (60 min)

Teaching and Learning's Activity	Materials
<ul style="list-style-type: none"> - Explain the experimental procedures of how to prepare a polypyrrole film through electrolysis to students. - Students start to produce 4 types of polypyrrole films base on 4 different dopants. - Compare the physical appearances of 4 types of polypyrrole films and make conclusion. 	<ul style="list-style-type: none"> - Student Worksheet-1 - Equipments and chemicals needed for the electrolysis of pyrrole.

Third Period: Measurement of Polypyrrole Conductivity (60 min)

Teaching and Learning's Activity	Materials
<ul style="list-style-type: none"> - Explain the procedures of how to examine conductivity of the polypyrrole films by using the hand-made 4T sensing apparatus. - Students start to examine the conductivity of their polypyrrole films they have made. - Encourage students to work in groups and discuss what they find out from their experimental data, then ask students to present their own conclusion and suggest one polypyrrole film that provides best conductivity among the four types they 	<ul style="list-style-type: none"> - Student Worksheet-2 - Improvised 4T sensing - DC-transformer, ruler, scissors, tape

made.

- Encourage students to research more on polypyrrole plastic and its application in order to better understand its characteristic.
- Deliver Post-lesson assessment and Questionnaires

- Post-lesson assessment test and Questionnaires

IV. Pre/Post Test

1. Have you ever heard a plastic can conduct electricity? Yes No

2. If Yes, can you name the one you know? And what it is used for?

.....

3. The following are four types of polypyrrole structures. Do you think which types may able to conduct electricity? (You can choose more than one answer)

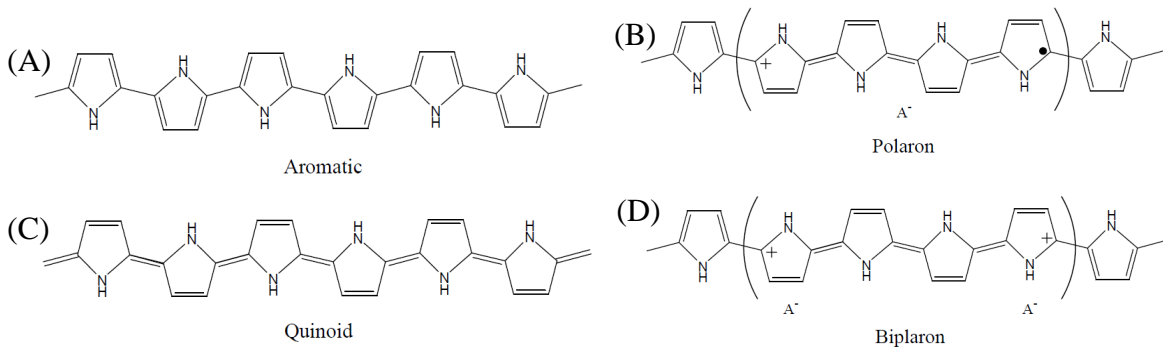

Explain your answer:

.....

4. A material with cross sectional area A , length l is passed though by a current I and potential V . We know that the resistivity $\rho = R \frac{A}{l}$ and the conductivity of a material is the reverse of its resistivity $\kappa = \frac{1}{\rho}$. From this view point, tell what measurements do you need to examine in order to determine conductivity of the material?

.....

.....

.....

IV. Questionnaires

1. In general, how much did you understand today lesson?

- A. Clearly understood B. Understood
C. Somehow understood D. Did not understand at all

2. Write down two knowledge and/or skills that you learned and understood from the today class.

- (1). _____
(2). _____

3. How much did you interest in today lesson?

- A. Much interested B. Interested
C. Little interested D. Did not interest at all

4. Write down one concept and/or activity that you interested most from the today class.

- (1). _____

5. Do you think the improvised conductivity apparatus can be applied and used easily by other students at your school?

- A. Very easy B. Easy
C. Not too easy, but feasible D. Very Difficult

6. Write down one concept or one activity that you were not clear or did not understand (if any).

7. Write down one concept or one activity that you did not interest (if any).

8. More comments and suggestions about today lesson:

APPENDIX FOR CHAPTER VI

I. Student Handout : Viscosity and Intermolecular Forces

Objectives

To understand the microscopic interaction of particles in solutions by observing viscosity.

After the lessons, students are expected to answer the following questions:

How metal ions affect viscosity of CMC (aq)?

Dropping viewpoint: *faster or slower?*

When viscosity of a solution is higher, dropping speed of a plastic gun ball in the solution is

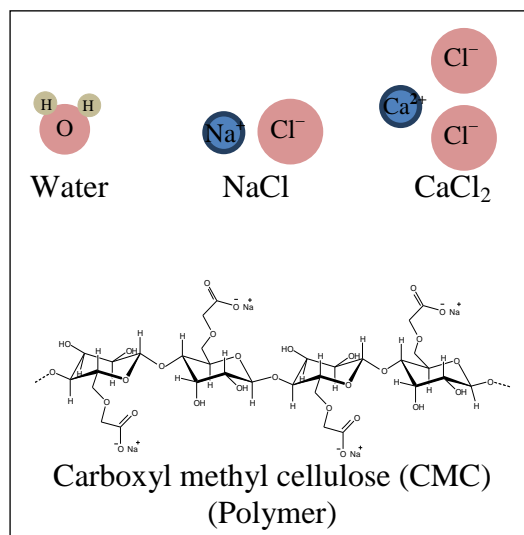

II. Student Worksheets

<Experiment-1>

Hypothesis

What do you think the viscosity of (A) water, (B) 0.5% NaCl solution and (C) 0.5% Caboxyl Methyl Cellulose (CMC) solution?

1. A = B = C 2. A > B > C 3. A < B < C 4. Other: _____

Experimental procedures

1. Install a transparent tube with a stopper at lower end vertically clamped to a stand. (The tube has two marks 500mm apart and its inner diameter is 20mm). See the picture on the right.
2. Pour 250 mL of distilled water into the tube.
3. Drop a plastic gun ball into the tube from the top, and start the stopwatch when the ball reaches the upper mark on the tube, and stop it when the ball reaches the lower mark. Record the dropping time. Repeat the drop three times.
4. Transfer the distilled water from the tube into a beaker and add 1.25g of NaCl into the water and dissolve well. The concentration of NaCl in the solution will be 0.5%.
5. Pour the NaCl(aq) solution back to the tube and then follow the procedure-3 to measure the dropping speed.
6. Investigate the dropping time with the same procedure for 0.5% CMC.

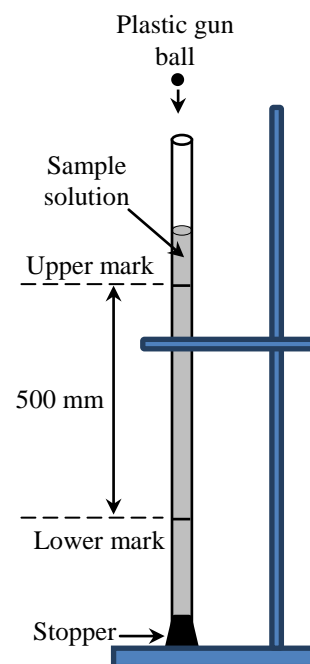

Experimental Results

	Sample solutions		
	(A) Distilled water	(B) NaCl(aq), 0.5%	(C) CMC, 0.5%
Dropping times (s)	1 st .		
	2 nd .		
	3 rd .		
Average (s)			
Dropping speed (mm s ⁻¹)			

- Is your prediction correct? Yes / No

- Write the results you found:

<Experiment-2>

Hypothesis

What happens to the viscosity if NaCl is added into the 0.5% CMC solution? Please predict a viscosity order between: (C) 0.5% CMC and (D) 0.5% CMC + NaCl

1. C = D 2. C > D 3. C < D

Experimental procedures

1. Transfer the 0.5% CMC from the tube into a beaker and add 0.25g of NaCl and dissolve well. The concentration of NaCl in the solution will be 0.017mol kg^{-1} .
2. Investigate the dropping time with the same procedures in the worksheet-1 for this mixture.

Experimental Results

	(D) 5% CMC + 0.017mol kg^{-1} NaCl
Dropping times (s)	
Average (s)	
Dropping speed (mm s^{-1})	

- Is your prediction correct? Yes / No

- Write the result you found comparing between (C) & (D): _____

<Experiment-3>

Hypothesis

What happens to the viscosity if CaCl_2 is added into the 0.5% CMC solution, instead of NaCl? Please predict viscosity of (E) 0.5% CMC + CaCl_2 comparing to (C) 0.5% CMC solution and (D) 0.5% CMC + NaCl by adding >, < or = to the following gapes.

E C and E D

Experimental procedures

3. Pour away the solution of 0.5% CMC + NaCl from the tube into a beaker. Wash the tube with distilled water and install back on the stand.
4. In a beaker, add 0.62 g of $\text{CaCl}_2 \cdot 2\text{H}_2\text{O}$ into new 250 mL of 0.5% CMC, and dissolve well. The concentration of CaCl_2 will be $0.017 \text{ mol kg}^{-1}$.
5. Investigate the dropping time with the same procedures in the worksheet-1 for this mixture.

Experimental Results

	(E) 5% CMC + $0.017 \text{ mol kg}^{-1} \text{ CaCl}_2$
Dropping times (s)	
Average (s)	
Dropping speed (mm s^{-1})	

- Is your prediction correct? Yes / No

- Write the result you found comparing between (C), (D)& (E):

Summary Discussion

- (1). Using the results of the three experiments, plot bar charts in the following graph.

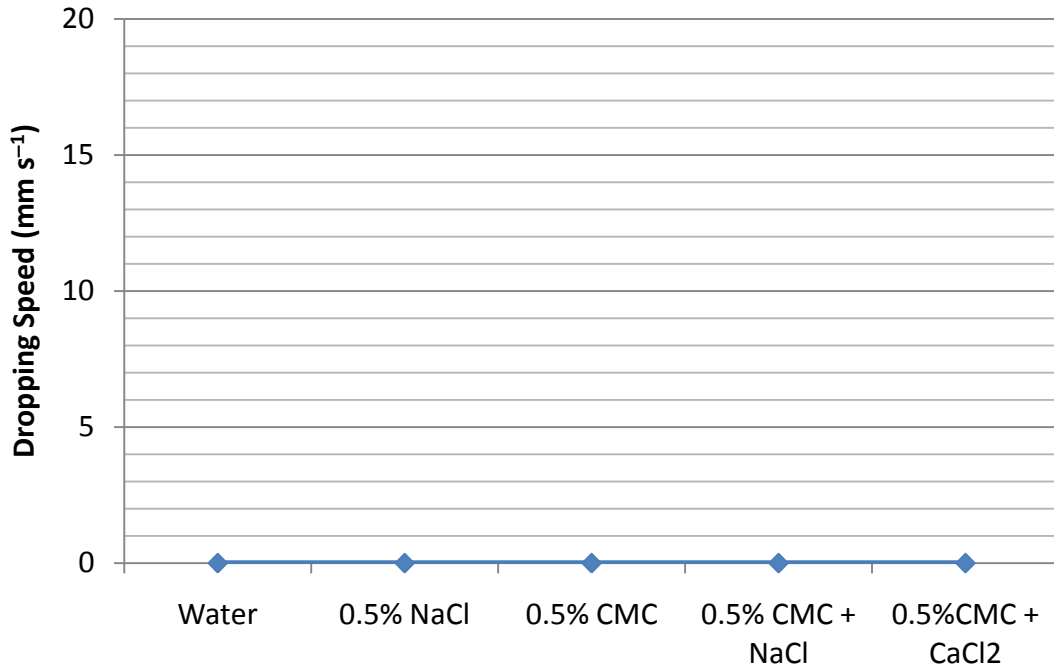

(2). By using **molecular structure** viewpoints, answer the following questions:

- What makes the 0.5% CMC(aq) viscosity higher than water and NaCl(aq)?

.....

- What make the viscosity of the CMC (aq) decrease when NaCl is added?

.....

- Why can CaCl₂ decrease the viscosity of the CMC(aq) more than NaCl?

.....

- In conclusion, how do metal ions affect viscosity of CMC(aq)?

.....

III. Lesson Plan

Lesson Duration: 2 periods

Objective: Through this lesson, students will be able:

- To develop the basic concepts of viscosity and to understand interaction amongst particles in solutions through microscopic viewpoints.
- To increase their interests in science lesson through macroscopic observation to microscopic explanation.

Materials:

Apparatus: A transparent plastic tube with a stopper at one end, stand with clamps, washing bottle, tissue paper, 300mL beaker, plastic gun ball.

Chemical: Distilled water, 0.5% aqueous carboxyl methyl cellulose (CMC), NaCl(s) and CaCl₂(s).

Lesson Progress:

First Period: Introduction and investigation of water, NaCl(aq) and CMC(aq) viscosity (50 min)

Teaching and Learning's Activity	Materials
1. Greeting and Self-introduction	- Pre-assessment sheet
2. Pre-lesson assessment	
3. Lesson introduction: show two daily liquids to students, water and cooking oil. Ask students to describe the different natures of the two liquids. Generate “Viscosity” term for today lesson.	- Student worksheet-1
Then a brainstorm question is asked:	- transparent tube, stand, clamp, plastic gun ball,
Question: How do you examine different viscosity of different liquids? What make solutions different viscosity from one another?	
	- 300 mL beakers

<p>4. Introduce Oswald Viscometer. <i>Just Demonstration.</i></p> <p>5. Introduce a transparent plastic tube for dropping method, and distribute experimental worksheet-1</p> <p>6. Following the worksheet-1, encourage students to develop hypothesis with reasoning explanation.</p> <p>7. Let students conduct investigation and collect data as a group.</p> <p>8. Encourage students to show their finding and reflect whether their hypothesis was correct.</p>	<p>- Stirring rod</p> <p>- Distilled water, NaCl(s), and 0.5% aqueous CMC.</p>
--	--

Second Period: Investigation of effect of Na⁺ and Ca²⁺ ions on CMC viscosity (50 min)

Teaching and Learning's Activity	Materials
<p><u>Effect of Na⁺ ions</u></p> <p>1. Distribute experimental worksheet-2 to student</p> <p>2. Along the worksheet, encourage students discuss as a group to formulate hypothesis with reasoning explanation.</p> <p>3. Let students conduct experiment to investigate their hypothesis.</p> <p>4. Encourage students to show their experimental results and reflect to their hypothesis.</p>	<p>- Student Worksheet-2 and -3</p> <p>- transparent tube, stand, clamp, plastic gun ball,</p> <p>- 300 mL beakers</p> <p>- Stirring rod</p>
<p><u>Effect of Ca²⁺ ions</u></p> <p>5. Distribute experimental worksheet-3</p> <p>6. Encourage students to formulate hypothesis as a group along with the worksheet.</p> <p>7. Let students conduct experiment and investigate their hypothesis.</p> <p>8. Encourage students to show their experimental results and reflect to their hypothesis.</p>	<p>- 0.5% aqueous CMC, NaCl, and CaCl</p>

V. Questionnaire

1. In general, how much did you understand the lesson today?

- A. Clearly understood B. Understood
C. Somewhat understood D. Did not understand at all

2. Write down two concepts and/or skills you most understood from the lesson today.

(1). _____

(2). _____

3. How much were you interested in the lesson today?

- A. Much interested B. Interested
C. Little interested D. Did not interest at all

4. Write down one concept and/or activity that you interested most from the today lesson.

(1). _____

5. Do you think the improvised apparatus can be applied and used easily by other students at your school?

- A. Very easy B. Easy
C. Not too easy, but feasible D. Very Difficult

6. Write down one concept or one activity that you were not clear about or did not understand (if any).

7. Write down one concept or one activity that did not interest you (if any).

8. More comments and suggestions about the lesson today:

APPENDIX OF JOURNAL PUBLICATION

Published papers which are based on this dissertation

Author and co-authors	Paper title	Name of the Journal	Date of publication	Others
Set Seng, Masakazu Kita, Reiko Sugihara	New Analytical Method for the Determination of Detergent Concentration in Water by Fabric Dyeing	Journal of Chemical Education, 84(11), pp.1803-1805	November, 2007	
Set Seng, Masakazu Kita	Development of a Handmade Conductivity Measurement Apparatus and Application to Vegetable and Fruits	Journal of Chemical Education, 91(4), pp.892-897	May, 2014	
Set Seng, Shinpei Tomita, Yoshihiko Inada, Masakazu Kita	Development of a Handmade Conductivity Measurement Device for a Thin-Film Semiconductor and Its Application to Polypyrrole	Journal of Chemical Education, 91(8), pp1971-1975	August, 2014	
Set Seng, David Ford, Sieng Sovanna, Masakazu Kita	Cambodian Students' Competencies in Chemistry at Lower Secondary School Compared to Regional Neighbors and Japan	Journal for the Science of Schooling, Hyogo University of Teacher Education, 16, 169-181	March, 2015	
Set Seng, David Ford, Masakazu Kita,	Effects of Metal Ions on Viscosity of Aqueous Sodium Carboxymethylcellulose solution and Development of Dropping Ball Method on Viscosity	Journal of Chemical Education, 92(5), pp.946-949	April, 2015	